

General Description

Positive constant displacement, rotary, three screw pump. Flow rate per revolution 9.8 - 425 cm³ in 14 steps. The three screws, the central driven screw – the power rotor – which meshes with the two sealing screws – the idler rotors – the only rotating components of the pump, are hydrodynamically journalled in the pump housing. The axial pressure and friction loads on the pump rotors are hydraulically balanced. The power rotor is positioned axially by a ball-bearing which operates at principally no axial load due to the hydraulic balancing of the rotor axial forces.

The following models comprise the E4 pump with a circular connecting frame – for mounting of the pump to an air/fluid cooled flanged electric motor. The connecting frame comprises the pump shaft seal of the lip seal type.

- **E4 xxBE** with radial inlet for horizontal or vertical mounting.
- **E4 xxTE** with built-on inlet strainer for tank-top mounting for shallow tank operation.
- **E4 xxJE** as E4 xxTE with extended inlet pipe for deep tank operation.

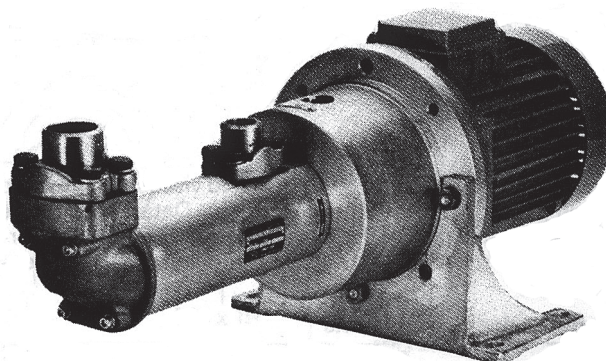

E4 z4 LRBE-unit

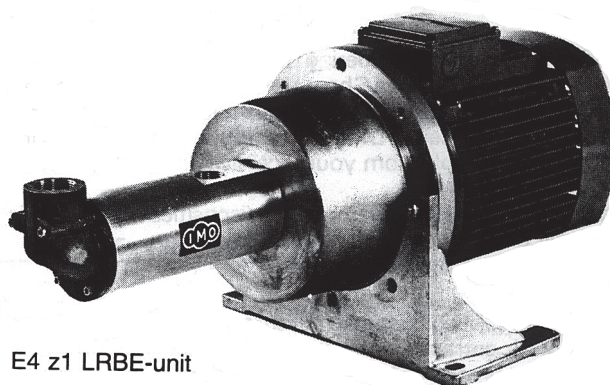

E4 z1 LRBE-unit

Model Code

Series	E4									A		
Size (Power rotor diameter, mm) 025-032-038-045-052-060-070												
Rotor lead L = Low (025-032) K = Low (038-070) N = Normal (all sizes)												
Generation 1 = Standard - 025-052 with connections with BSP-thread 060-070 with SAE flange connections 4 = Modification - 025-052 with SAE flange connections												
Material in pump body L = Aluminium Y = Pearlitic cast iron, surface treated												
Shaft seal (situated in connecting frame/front cover) E = Without shaft seal (= pump without connecting frame/front cover) R = Radial shaft seal, nitrile (= pump with connecting frame/front cover) V = Radial shaft seal, viton (= pump with connecting frame/front cover)												
Mounting design B = Flange mounted J = For vertical tank mounting; with prolonged inlet pipe T = For vertical tank mounting; with mounted strainer												
Other characteristics E = Without valve												
Special design A101 = Pump, pumping in counter clockwise direction A141 = Pump with special front cover in order to replace ALA- and B4 pumps												

Material

Pump rotors - hardened alloy steel

Rotor housing - aluminium alloy/surface treated cast iron

Connecting frame - aluminium alloy

Shaft seal - Nitrile rubber lip sea

For handling of fire resistant hydraulic fluids on phosphate ester base and fluids which may be aggressive to above materials – consult IMO AB.

Design Limits*

Max. Discharge Pressure: 10 MPa

Reduced pressure limits apply due to fluid viscosity, rotor lead and pump speed. Consult the Performance Data Sheet for the individual pump size. The Performance Data Sheet or the corresponding information is available from your local IMO AB representative.

Recommended Speed Limits

Size	Maximum Speed r/s- rpm
025, 032	83 - 5000
038	75 - 4500
045, 052	73 - 4400
060, 070	66 - 4000

Speed to be selected considering pump inlet conditions. Consult the Performance Data Sheet for the individual pump size regarding suction lift capability or positive inlet pressure required. The Performance Data Sheet or the corresponding information is available from your local IMO AB representative.

Fluid Viscosity: 12-400 mm²/s. Viscosities beyond this range only after approval by IMO AB.

Pumping Temperature: Lxxx 0°C - + 90°C
Yxxx - 20°C - + 90°C

Inlet Pressure: Max. negative pressure: - **0.3 bar**, considering the risk of air entrainment at the shaft seal. Max. positive pressure: 100- 500 kPa- (depending on speed.) Further information is available from your local IMO AB representative.

Rotation: Clockwise facing pump shaft.

Drive: Direct drive over flexible shaft coupling which must allow an axial pump shaft movement of min. 0.3 mm. Axial or transverse loads on pump shaft not allowed.

Displacement

Flow per revolution cm ³							
Size	025	032	038	045	052	060	070
L/K Lead	9.8	20.6	38.8	65.2	103	159	251
N Lead	13.9	29.1	49.1	81.6	126	193	307

* In this leaflet following units are used:

Quantity	SI-Unit	Other Unit	Conversion
Pressure	MPa, kPa	-	MPa = 10 bar
Speed	r/ s	rpm	-
Viscosity	mm ² /s	-	1 mm ² / s = 1 cSt
Temperature	°C	-	-
Length	m, mm, µm	-	-
Volume	cm ³	-	-
Flow rate	dm ³ / s	l/mm	-

Sound Level

Typical E4 xxBE pump sound levels referred to free field conditions at a distance of 1 m from the pump. Noise of driver excluded in quoted figures.

Sound pressure level dB(A) at 2940 rpm, 20 mm ² /s, 50 °C		025	032	038	045	052	060	070	
L/K	Size								
Lead	Dis-charge	2 MPa	52	54	56	60	63	67	70
		7 MPa	54	55	59	63	66	69	74
Lead	press-ure	2 MPa	55	56	60	63	67	70	72
		7 MPa	57	59	62	66	69	72	75

Moment of Inertia

Moment of inertia for bare shaft pump.

Size	kgm ²
025	0.00002
032	0.00007
038	0.00016
045	0.00038
052	0.00076
060	0.0016
070	0.0034

Filtration

In order to protect the E4-pump from foreign matter, such as weld slag, weld beads, pipe scale and rust, nuts, bolts, rags etc., a strainer should be installed in the pump inlet pipe near the pump. Recommended strainer open- meshwidth for the E4-pump is:

400 - 800 µm at flow rates below 5 dm³/s (**300 l/min**)

600 - 1000 µm at flow rates above 5 dm³/s (**300 l/min**)

Max. pressure difference over clean strainer: 10 kPa at full flow rate.

The built-on strainer of pumps E4 xxJE/xxTE has an open meshwidth of 500 µm (30 mesh straining cloth).

When the E4 pump is used in power hydraulic system or is used as lube oil pump, no extra filtering precautions are required other than those prescribed for the remaining components in the system.

Unless other filtration is prescribed, we recommend that the hydraulic fluid of a power hydraulic system be pumped through a filter – in the return line to the fluid reservoir or in a separate fluid reconditioning circuit –with an open-mesh- width of 100 µm.

The size of the filter to be selected so the pressure difference over clean filter is max. 0.1 MPa at full flow rate.

Accessories

For the E4 pump following standard accessories are available.

- Angle foot for pump unit assembled with flanged IEC electric motor mounting form IM 3001.
- Flexible shaft coupling.
- Inlet/outlet counter flange set for pipe weld connection.
- Totally enclosed squirrel-cage electric motors according to IEC mounting forms IM 2001, IM 3001 and IM 3011.

Dimensions

Pump Series E4 xxBE, xxJE and xxTE

For complete pump dimensions consult the Dimension Print for the individual pump models.

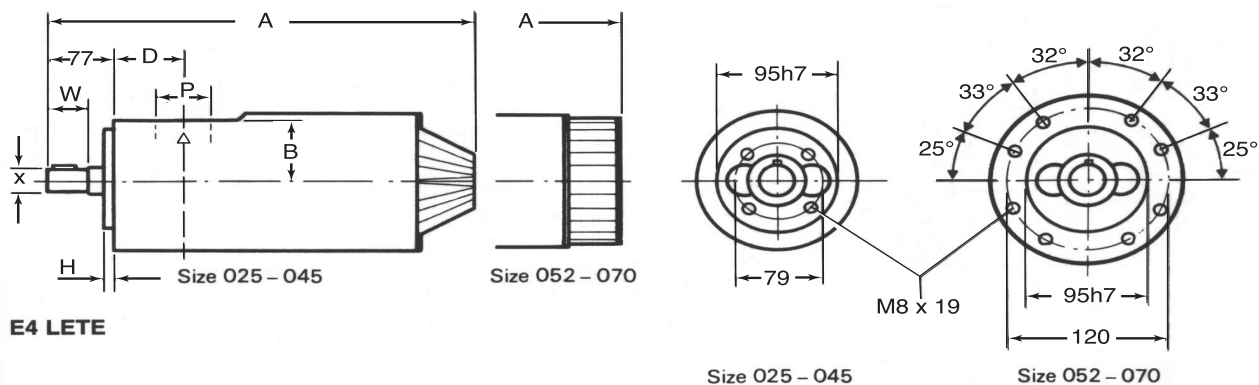

Size		025	032	038	045	052	060	070	
Main dimensions ¹	A	310	349	359	413	466	517	579	
	B	43	43	43	49	62	62	76	
	B ₁	70	70	75	85	90	95	105	
	D	60	60	60	80	80	95	95	
	E	163	202	214	258	293	359	427	
	Mmin	150	157	173	205	252	297	323	
	V ₁	70	70	70	80	100	100	100	
	V ₂	100	100	125	160	190	225	240	
H	5	5	5	5	4	4	4		
Outlet/Inlet Port ²	E4K1/N1	P	Ø	R1"	R1"	R1 1/4"	R1 1/2"	60	60
		T	Ø	R1 1/4"	R1 1/4"	R1 1/2"	R2"	60	98
E4 L4/K4/N4	P	25	25	25	32	40	—	—	
	T	32	32	38	50	60	—	—	
SAE Flanges ²	E4 K1/N1	P	—	—	—	—	2 1/2"	2 1/2"	
		T	—	—	—	2 1/2" *)	3"	4"	
E4 L4/K4/N4	P	1" *)	1" *)	1" *)	1 1/4" *)	1 1/2" *)	—	—	
	T	1 1/4"	1 1/4"	1 1/2"	2"	2 1/2" *)	—	—	
Shaft	W	35	35	55	55	55	55	55	
	X ³ Ø	19	19	32	32	32	32	32	
	Key ⁴	6x6	6x6	10x8	10x8	10x8	10x8	10x8	
Weight	E4 LE TE	5	6	7	12	18	25	37	

¹ Dimensions A1, A2, A3, C och C1, see table "Motor Connecting Frame" on page 4.

² Outlet/Inlet flange bolt pattern according to SAE Standard J518 for 3000 PSI (max.) working pressure and dimensions of from IMO AB for the E4 pump available counter flanges, see table "Counter Flange Set" below.

³ Tolerance ISO j6.

⁴ Key/keyway ISO/R 773- 1969.

Counter Flange Set

Pipe Weld Counter Flange comprising pipe weld, "O"-ring, SAE J5 18 split flange and bolts – bolts in steel property Class ISO 8.8 and with min. length E.

Dimension E has to be subtracted with 5 mm regarding the counter flange sets marked with '*' in the table above.

**) Pipe weld connection set size 2 1/2" for the pump outlet port has dimension E = 40 mm

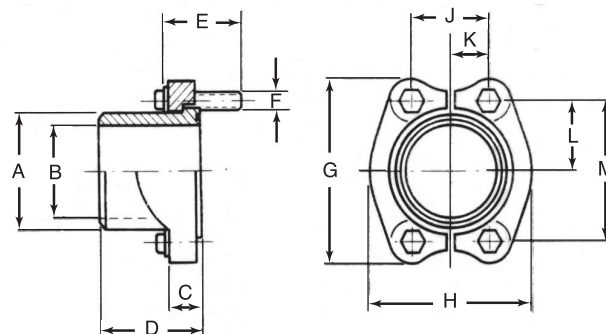

Flange Size	A	B	C	D	E**	F	G	J	K	L	M
1"	38	25	16	45	35	M10	70.0	26.2	13.1	26.2	52.4
1 1/4"	43	32	14	50	35	M10	80.0	30.2	15.1	29.4	58.7
1 1/2"	50	40	16	50	40	M12	94.0	35.8	17.9	34.9	69.8
2"	62	50	17	55	40	M12	101.5	43.0	21.5	39.0	78.0
2 1/2"	74	60	19	75	45	M12	114.0	51.0	25.5	44.5	89.0
3"	90	75	22	85	55	M16	135.0	62.0	31.0	53.0	106.0
4"	114	100	26	90	55	M16	162.0	78.0	39.0	65.0	130.0

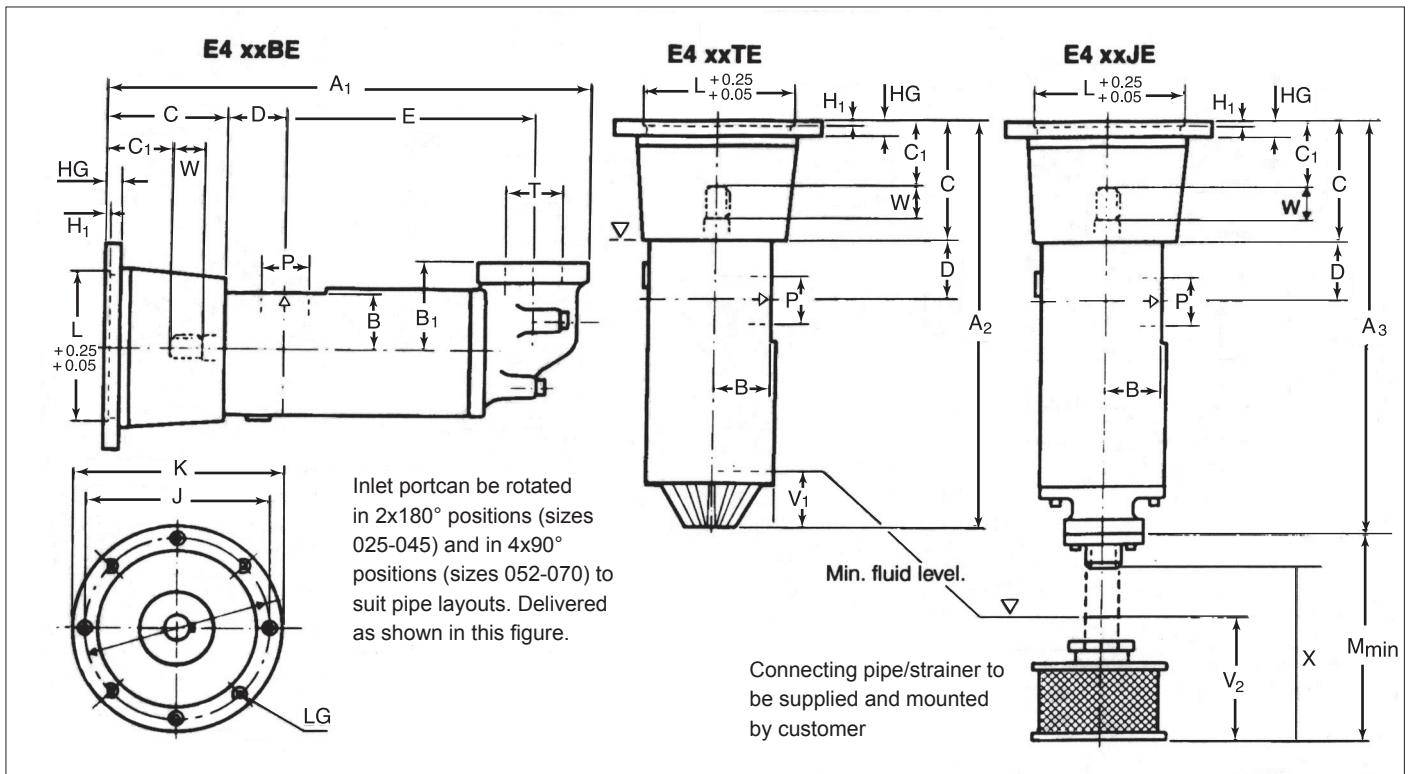

Inlet dimensions (mm)

Pump size	025	032	038	045	052	060	070
X min	115	117	133	160	252	297	323
X max	725	825	1450	1610	2015	2025	1675

Pump Size	Motor Connecting Frame												Approx. Weight, kg E4 Lxxx
	Frame Size	A ₁	A ₂	A ₃	C	C ₁	H ₁	HG	J Dia.	K Dia.	L Dia.	LG Dia.	
025	F165	384	363	379	130	53	4	26	165	200	130	M10	7 - 9
	F215	394	373	389	140	63	5	18	215	250	180	M12	8 - 10
	F265	417	396	412	163	86		28	265	300	230		8 - 10
032	F165	423	402	418	130	53	4	26	165	200	130	M10	8 - 10
	F215	433	412	428	140	63	5	18	215	250	180	M12	9 - 10
	F265	456	435	451	163	86		28	265	300	230		10 - 11
038	F300	487	466	482	194	117	6	47	300	350	250	M16	12 - 14
	F215	447	422	440	140	63	5	18	215	250	180	M12	10 - 12
	F265	470	445	463	163	86		28	265	300	230		12 - 14
045	F300	501	476	494	194	117	6	47	300	350	250	M16	12 - 14
	F215	518	476	491	140	63	5	18	215	250	180	M12	15 - 16
	F265	541	499	514	163	86		28	265	300	230		17 - 18
052	F300	572	530	545	194	117	6	47	300	350	250	M16	18 - 20
	F350	568	526	541	190	113	6	44	350	400	300	M16	20 - 22
	F265	591	552	557	163	86	5	28	265	300	230	M12	22 - 24
060	F300	622	583	588	194	117	6	47	300	350	250	M16	24 - 26
	F350	618	579	584	190	113	6	44	350	400	300	M16	25 - 27
	F400	653	614	619	225	148	6	30	400	450	350	M16	27 - 29
070	F500	658	619	624	230	153	6	26	500	550	450	M16	29 - 31
	F300	714	634	655	194	117	6	47	300	350	250	M16	31 - 34
	F350	710	630	651	190	113	6	44	350	400	300	M16	32 - 35
070	F400	745	665	686	225	148	6	30	400	450	350	M16	34 - 37
	F500	750	670	691	230	153	6	26	500	550	450	M16	36 - 39
	F300	792	696	717	194	117	6	47	300	350	250	M16	43 - 47
070	F350	788	692	713	190	113	6	44	350	400	300	M16	44 - 48
	F400	823	727	748	225	148	6	30	400	450	350	M16	46 - 50
	F500	828	732	753	230	153	6	26	500	550	450	M16	48 - 52
	F600	833	737	758	235	158	8	50	600	660	550	M20	50 - 54

Remark

Motor connecting frame size denomination (= motor mounting flange size) refers to pitch diameter of holes for mounting bolts.

Dimensions Pump Unit Type E4 xxBE, xxJE and xxTE

with flange mounted IEC electric motors, in Unit Mounts I, II and III.
For complete pump unit dimensions consult the Dimension
Print for the individual unit mount.

Dimensions in mm.

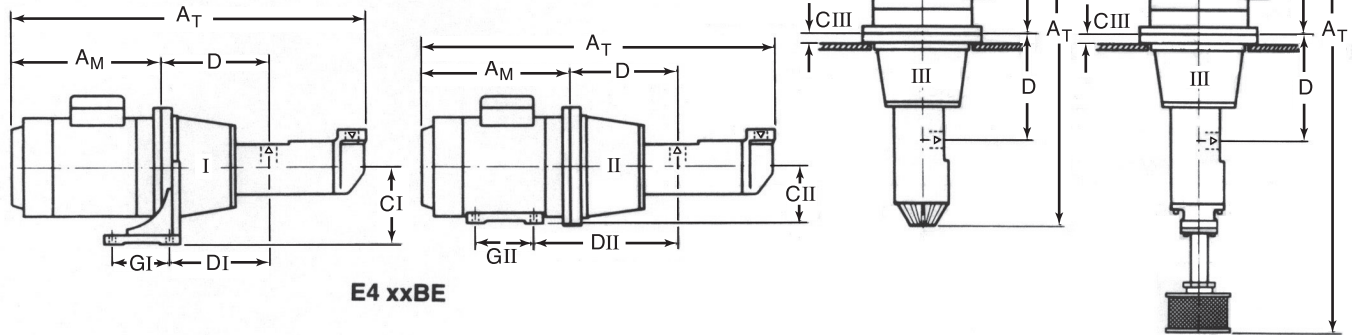

Pump Unit

Pump Size	TEFC Electric Motor		Unit Mount			Approx. weight without e-motor kg		Overall Length AT											
	IEC No.	Mounting Flange	I	II	III	I	II/III	E4F	E4T	E4V	AM	D	C _I	D _I	G _I	C _{II}	D _{II}	G _{II}	C _{III}
025	80, 90	F165	•	•	•	9	8	734	713	844	350	190	126	171	95	80/90	240/246	100-125	26
	100,112	F215	•	•	•	12	10-11	789	768	904	395	200	152	187	115	100/112	263/270	140	18
	132	F265	•	•	•	15	12-13	852	831	962	435	223	183	201	140	132	312	140-178	28
032	80/90	F165	•	•	•	10	9	773	752	885	350	190	126	171	95	80/90	240/246	100-125	26
	100,112	F215	•	•	•	13	11-12	828	807	940	395	200	152	187	115	100/112	263/270	140	18
	132	F265	•	•	•	16	13-14	891	870	1003	435	223	183	201	140	132	312	140-178	28
038	160,180	F300	•	•	•	20	16	1084	1063	1196	597	254	210	214	170	160/180	362/375	210-279	47
	100,112	F215	•	•	•	14	12-13	842	817	968	395	200	152	187	115	100/112	263/270	140	18
	132	F265	•	•	•	17	14-15	905	880	1031	435	223	183	201	140	132	312	140-178	28
045	160,180	F300	•	•	•	21	16-18	1098	1073	1224	597	254	210	214	170	160/180	362/375	210-279	47
	100,112	F215	•	•	•	20	17-19	913	871	1046	395	220	152	207	115	100/112	283/290	140	18
	132	F265	•	•	•	23	19-21	976	934	1109	435	243	183	221	140	132	332	140-178	28
052	160,180	F300	•	•	•	27	22-23	1169	1127	1302	597	274	210	234	170	160/180	382/395	210-279	47
	200	F350	•	•	•	35	28-30	1268	1226	1401	700	270	240	233	200	200	403	305	44
	132	F265	•	•	•	30	25-27	1026	987	1244	435	243	183	221	140	132	332	140-178	28
	160,180	F300	•	•	•	33	28-30	1219	1180	1437	597	274	210	234	170	160/180	382/395	210-279	47
	200	F350	•	•	•	41	34-36	1318	1279	1536	700	270	240	233	200	200	403	305	44
060	225	F400	•	•	•	—	37-39	1503	1464	1721	850	305				225	454	286-311	30
	250, 280	F500	•	•	•	—	41-43	1658	1619	1876	1000	310				250/280	478/500	349/419	26
	160, 180	F300	•	•	•	41	35-38	1311	1231	1549	597	289	210	249	170	160/180	397/410	210-279	47
	200	F350	•	•	•	49	41-44	1410	1330	1648	700	285	240	248	200	200	418	305	44
	225	F400	•	•	•	—	44-47	1595	1515	1833	850	320				225	469	286-311	30
070	250, 280	F500	•	•	•	—	48-51	1750	1670	1988	1000	325				250/280	493/515	349/419	26
	160, 180	F300	•	•	•	63	56-60	1389	1293	1637	597	289	210	249	170	160/180	397/410	210-279	47
	200	F350	•	•	•	62	53-57	1488	1392	1736	700	285	240	248	200	200	418	305	44
	225	F400	•	•	•	—	56-60	1673	1577	1921	850	320				225	469	286-311	30
	250, 280	F500	•	•	•	—	60-64	1828	1732	2076	1000	325				250/280	493/515	349-419	26
	315	F600	•	•	•	—	72-76	1863	1767	2111	1030	330				315	546	406-457	50

Remarks

1. TEFC = totally enclosed (IP 54) fan cooled (IC 41). For other motor types compare mounting flange size with column "Mounting Flange".
2. Dimensions AT and AM may vary with make of electric motor.
3. E4 xx JE: Overall length AT corresponds to minimum length of pump inlet pipe.
4. For certain motor sizes the motor mounting flanges projects (max. 25 mm) below the motor foot.
5. E4 xxBE 045 F215 in Unit Mount I: The angle foot mounted with the floor fastening bolts under the connecting frame (reversed position compared to that shown in Unit Mount I).

Selection Guide for Pump Series E4

Flow Rate and Power Consumption at 50 Hz and 60 Hz with 2-pole and 4-pole air/fluid cooled electric motors at 37 mm²/s viscosity and for pumping temperatures up to 60 °C. Consult the Performance Data Sheet for the individual pump size for performance data at other speeds, viscosities and pumping temperatures. The Performance Data Sheet or the corresponding information is available from your local IMO AB representative. Electric motor power to be selected considering viscosity and discharge pressure at start-up conditions. Pump performance established according to VDMA 24284.

For information about Flow Rate and Power Consumption between 70 - 100 bar please contact your IMO AB representative.

Flow rate and power consumption at 50 Hz

Flow rate (Q_{eff}) dm³/s, (O_{eff}) l/min and Power Consumption (P_e) kW at 37 mm²/s, ≤ 60°C

Speed		24 r/s (1450 rpm)							48 r/s (2900 rpm)						
Size	Discharge pressure	1 Mpa	2 Mpa	3Mpa	4 Mpa	5 Mpa	6 Mpa	7 Mpa	1 Mpa	2 Mpa	3 Mpa	4 Mpa	5 Mpa	6 Mpa	7 MPa
025L	Q _{eff}	0.19	0.17	0.16	0.14	0.12	-	-	0.43	0.41	0.39	0.38	0.36	0.34	0.33
	Q_{eff}	12	10	9	8	7	-	-	26	24	24	22	22	21	20
	Pe	0.3	0.5	0.8	1.0	1.3	-	-	0.6	1.1	1.6	2.1	2.6	3.1	3.6
025N	Q _{eff}	0.27	0.24	0.21	0.19	-	-	-	0.60	0.57	0.55	0.52	0.50	0.48	0.45
	Q_{eff}	16	14	13	11	-	-	-	36	34	33	32	30	29	27
	Pe	0.4	0.8	1.1	1.4	-	-	-	0.9	1.6	2.3	3.0	3.7	4.4	5.1
032L	Q _{eff}	0.43	0.41	0.38	0.36	0.34	0.31	0.29	0.93	0.90	0.88	0.86	0.83	0.81	0.79
	Q_{eff}	26	24	23	22	20	19	17	56	54	53	51	50	48	47
	Pe	0.6	1.1	1.6	2.1	2.7	3.2	3.7	1.3	2.3	3.4	4.4	5.4	6.5	7.5
032N	Q _{eff}	0.61	0.57	0.54	0.50	0.47	0.43	0.40	1.31	1.27	1.24	1.20	1.17	1.14	1.10
	Q_{eff}	36	34	32	30	28	26	24	79	76	74	72	70	68	66
	Pe	0.9	1.6	2.3	3.0	3.8	4.5	5.2	1.8	3.3	4.8	6.2	7.7	9.2	10.6
038K	Q _{eff}	0.84	0.80	0.76	0.73	0.69	0.66	0.63	1.78	1.73	1.70	1.66	1.63	1.60	1.56
	Q_{eff}	50	48	46	44	42	40	38	107	104	102	100	98	96	94
	Pe	1.1	2.1	3.1	4.0	5.0	6.0	6.9	2.4	4.4	6.4	8.3	10.3	12.2	14.2
038N	Q _{eff}	1.07	1.03	0.98	0.94	0.90	0.86	0.82	2.26	2.21	2.17	2.13	2.09	2.05	2.01
	Q_{eff}	64	62	59	57	54	52	49	135	133	130	128	125	123	120
	Pe	1.4	2.7	3.9	5.1	6.3	7.6	8.8	3.1	5.6	8.0	10.5	13.0	15.5	17.9
045K	Q _{eff}	1.46	1.41	1.37	1.33	1.28	1.24	1.20	3.03	2.98	2.94	2.90	2.86	2.81	2.77
	Q_{eff}	88	85	82	80	77	75	72	182	179	176	174	171	169	166
	Pe	1.9	3.5	5.2	6.8	8.4	10.0	11.7	4.1	7.4	10.7	14.0	17.2	20.5	23.8
045N	Q _{eff}	1.83	1.78	1.73	1.68	1.63	1.58	1.53	3.80	3.74	3.69	3.64	3.60	3.55	3.50
	Q_{eff}	110	107	104	101	98	95	92	228	225	222	219	216	213	210
	Pe	2.4	4.4	6.5	8.5	10.5	12.6	14.6	5.1	9.2	13.4	17.5	21.6	25.7	29.8
052K	Q _{eff}	2.35	2.29	2.24	2.19	2.14	2.09	2.04	4.83	4.77	4.72	4.67	4.62	4.57	4.52
	Q_{eff}	141	137	134	131	128	125	122	290	286	283	280	277	274	271
	Pe	3.0	5.6	8.2	10.7	13.3	15.9	18.4	6.5	11.7	16.9	22.0	27.2	32.4	37.6
052N	Q _{eff}	2.88	2.81	2.74	2.68	2.62	2.56	2.50	5.91	5.84	5.78	5.72	5.66	5.60	5.54
	Q_{eff}	173	168	165	161	157	154	150	355	351	347	343	340	336	332
	Pe	3.7	6.8	10.0	13.1	16.3	19.4	22.5	7.9	14.3	20.6	27.0	33.3	39.7	46.0
060K	Q _{eff}	3.65	3.57	3.50	3.43	3.36	3.29	3.23	7.48	7.40	7.33	7.26	7.20	7.13	7.06
	Q_{eff}	219	214	210	206	202	198	194	449	444	440	436	432	428	423
	Pe	4.7	8.6	12.6	16.6	20.5	24.5	28.5	10.0	18.0	26.0	34.0	42.0	50.0	58.0
060N	Q _{eff}	4.44	4.34	4.26	4.17	4.09	4.01	3.92	9.09	8.99	8.91	8.82	8.74	8.66	8.57
	Q_{eff}	266	260	255	250	245	240	235	545	539	534	529	524	519	514
	Pe	5.7	10.5	15.3	20.1	24.9	29.7	34.5	12.2	21.9	31.6	41.3	51.0	60.7	70.5
070K	Q _{eff}	5.80	5.69	5.59	5.49	5.39	5.30	5.20	11.8	11.7	11.6	11.5	11.4	11.3	11.2
	Q_{eff}	348	341	335	330	324	318	312	711	704	698	692	687	681	675
	Pe	7.4	13.6	19.9	26.2	32.4	38.7	44.9	15.8	28.4	41.1	53.7	66.4	79.0	91.6
070N	Q _{eff}	7.09	6.95	6.83	6.71	6.60	6.48	6.36	14.5	14.4	14.2	14.1	14.0	13.9	13.8
	Q_{eff}	426	417	410	403	396	389	381	869	861	854	847	840	832	825
	Pe	9.0	16.7	24.3	32.0	39.6	47.3	54.9	19.3	34.8	50.3	65.7	81.2	96.6	112

Flow rate and power consumption at 60 Hz

Flow rate (Q_{eff}) dm³/s, (**Q_{eff}**) l/min and Power Consumption (Pe) kW at 37 mm²/s, ≤ 60°C

Speed		29 r/s (1750 rpm)							58 r/s (3500 rpm)						
Size	Discharge pressure	1 Mpa	2 Mpa	3Mpa	4 Mpa	5 Mpa	6 Mpa	7 Mpa	1 Mpa	2 Mpa	3 Mpa	4 Mpa	5 Mpa	6 Mpa	7 MPa
025L	Q _{eff}	0.24	0.22	0.20	0.19	0.17	0.16	-	0.53	0.51	0.49	0.47	0.46	0.44	0.42
	Q_{eff}	14	13	12	11	10	9	-	32	30	29	28	27	26	26
	Pe	0.4	0.6	0.9	1.2	1.5	1.8	-	0.8	1.4	2.0	2.6	3.2	3.8	4.3
025N	Q _{eff}	0.34	0.31	0.28	0.26	0.23	0.21	-	0.74	0.71	0.69	0.66	0.64	0.62	0.59
	Q_{eff}	20	20	18	17	16	14	13	44	43	41	40	38	37	35
	Pe	0.5	0.9	1.3	1.8	2.2	2.6	-	1.1	1.9	2.8	3.6	4.5	5.3	6.2
032L	Q _{eff}	0.54	0.51	0.49	0.46	0.44	0.42	0.39	1.14	1.11	1.08	1.06	1.04	1.01	0.99
	Q_{eff}	32	30	29	28	26	25	24	68	66	65	64	62	61	60
	Pe	0.7	1.4	2.0	2.6	3.2	3.9	4.5	1.6	2.9	4.1	5.4	6.6	7.9	9.1
032N	Q _{eff}	0.75	0.71	0.68	0.65	0.61	0.58	0.55	1.60	1.56	1.53	1.48	1.46	1.43	1.39
	Q_{eff}	45	43	41	39	37	35	33	96	94	92	90	88	86	84
	Pe	1.1	1.9	2.8	3.7	4.6	5.4	6.3	2.3	4.0	5.8	7.6	9.4	11.1	12.9
038K	Q _{eff}	1.03	0.99	0.96	0.92	0.89	0.85	0.82	2.16	2.12	2.09	2.05	2.02	1.98	1.95
	Q_{eff}	62	60	58	55	53	51	49	130	127	125	123	121	119	117
	Pe	1.4	2.6	3.7	4.9	6.1	7.3	8.4	3.0	5.4	7.8	10.1	12.5	14.9	17.2
038N	Q _{eff}	1.32	1.27	1.23	1.19	1.15	1.11	1.07	2.75	2.70	2.66	2.62	2.58	2.54	2.50
	Q_{eff}	79	76	74	71	69	66	64	165	162	160	157	155	152	150
	Pe	1.8	3.3	4.7	6.2	7.7	9.2	10.7	3.8	6.8	9.8	12.8	15.8	18.8	21.8
045K	Q _{eff}	1.79	1.74	1.69	1.65	1.61	1.57	1.53	3.68	3.63	3.59	3.55	3.51	3.47	3.4
	Q_{eff}	107	104	102	99	97	94	92	221	218	216	213	210	208	205
	Pe	2.4	4.3	6.3	8.3	10.2	12.2	14.2	5.1	9.0	13.0	17.0	21.0	25.0	28.9
045N	Q _{eff}	2.24	2.19	2.14	2.09	2.04	1.99	1.94	4.62	4.56	4.51	4.46	4.41	4.36	4.31
	Q_{eff}	135	131	128	125	122	119	116	277	274	271	268	265	262	259
	Pe	2.9	5.4	7.9	10.3	12.8	15.3	17.7	6.3	11.3	16.3	21.3	26.3	31.2	36.2
052K	Q _{eff}	2.86	2.81	2.75	2.70	2.65	2.60	2.55	5.86	5.80	5.75	5.70	5.65	5.60	5.55
	Q_{eff}	172	168	165	162	159	155	153	352	348	345	342	339	336	333
	Pe	3.7	6.8	9.9	13.0	16.1	19.3	22.4	8.0	14.3	20.6	26.9	33.1	39.4	45.7
052N	Q _{eff}	3.51	3.44	3.37	3.31	3.25	3.19	3.13	7.17	7.10	7.04	6.98	6.92	6.86	6.80
	Q_{eff}	210	206	202	199	195	191	188	430	426	422	419	415	411	408
	Pe	4.5	8.4	12.2	16.0	19.8	23.6	27.4	9.8	17.5	25.2	32.9	40.6	48.2	55.9
060K	Q _{eff}	4.45	4.37	4.30	4.23	4.16	4.09	4.02	9.07	8.99	8.92	8.85	8.79	8.72	8.65
	Q_{eff}	267	262	258	254	250	245	241	544	540	535	531	527	523	519
	Pe	5.7	10.5	15.3	20.1	24.9	29.7	34.5	12.4	22.1	31.8	41.5	51.2	60.9	70.6
060N	Q _{eff}	5.40	5.30	5.22	5.14	5.05	4.97	4.89	11.0	10.9	10.8	10.8	10.7	10.6	10.5
	Q_{eff}	324	318	313	308	303	298	293	661	655	650	645	640	635	630
	Pe	7.0	12.8	18.6	24.4	30.3	36.1	41.9	15.0	26.8	38.6	50.3	62.1	73.9	85.7
070K	Q _{eff}	7.05	6.94	6.84	6.75	6.65	6.55	6.46	14.4	14.2	14.1	14.1	14.0	13.9	13.8
	Q_{eff}	423	416	411	405	399	393	387	862	855	849	843	837	831	826
	Pe	9.1	16.6	24.2	31.8	39.3	46.9	54.5	19.5	34.8	50.2	65.5	80.8	96	111
070N	Q _{eff}	8.63	8.49	8.37	8.25	8.13	8.01	7.89	17.6	17.4	17.3	17.2	17.1	16.9	16.8
	Q_{eff}	518	509	502	495	488	481	474	1050	1050	1040	1030	1020	1020	1010
	Pe	11.1	20.3	29.6	38.9	48.1	57.4	66.6	23.9	42.6	61.3	80.1	98.8	118	136

Adress:

IMO AB
PO Box 42090, 126 14 Stockholm
Sweden