

# P-SERIES - P40 S

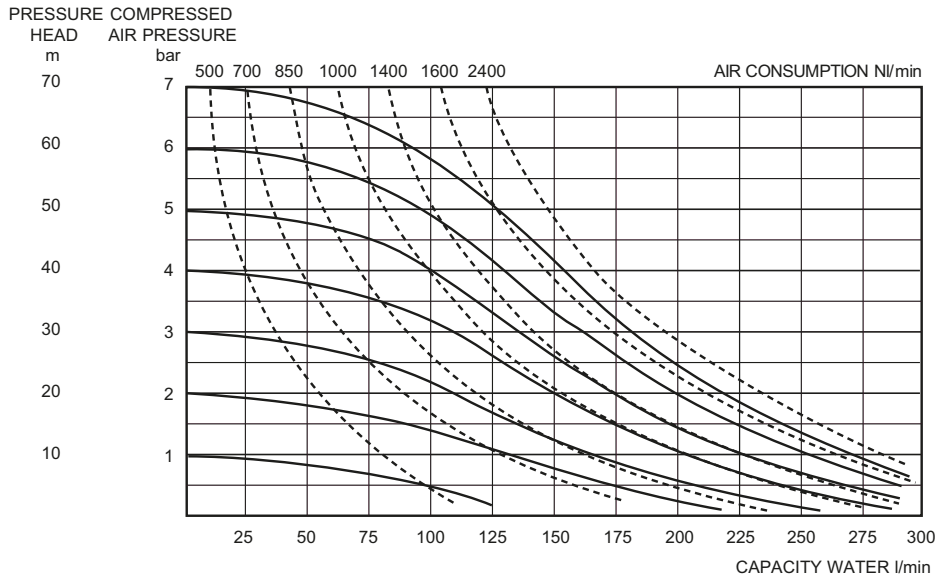

Please note that when a pump is fitted with Teflon® diaphragms, a capacity reduction of up to 15% may occur.

MATERIAL			SPECIFICATION						
Pump housing	Diaphragms	Valve balls	Max capacity	Max working pressure	Max Temp.	Liquid connection	Air connection	Particle size max.	Weight
SS316L	PTFE, Buna-N, EPDM	PTFE, Buna-N, EPDM, Vitron®	300 l/min	10 bar	100 °C	R2" female TC 2" SMS51	R1½" female	12 mm	32 kg

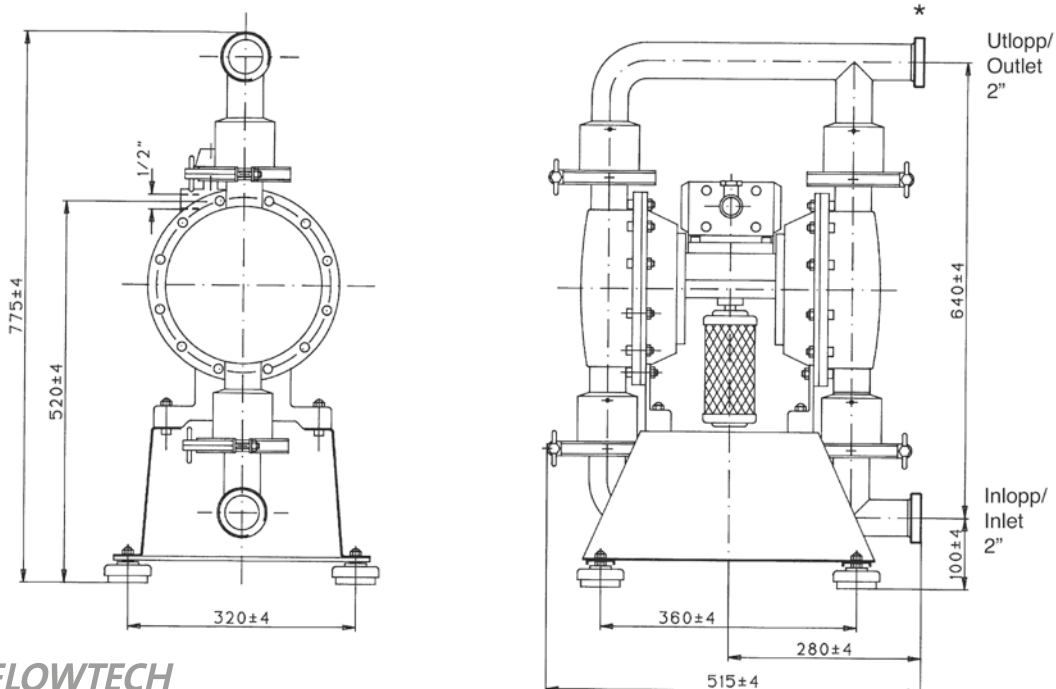

**CollyFLOWTECH**  
INNOVATIV FLÖDESTEKNIK



**Dominator Pump AB**

CollyFlowtech Group

Postal address  
Grossistgatan 3  
553 02 JÖNKÖPING

Delivery address  
Grossistgatan 3  
553 02 JÖNKÖPING

Telephone  
+46 (0)36-18 11 60

E-mail  
info@dominator.se  
Web  
www.dominator.se

VAT nr  
556209-3962

