

Multistage Centrifugal Pumps

HEGA 2502 ... 8009

TECHNICAL DATA

| | |
|------------------------|--|
| Flow: | max. 190 m ³ /h |
| Head: | max. 425 m |
| Speed: | max. 3600 rpm |
| Material: | Cast iron (0B, 0C, 0D, 0E, 0R, 0S, 0U) Stainless steel (4B) Spheroidal graphite cast iron (1B) |
| Temperature: | max. 190 °C, depending on the shaft sealing and the materials execution. |
| Casing pressure: | max. 40 bar, depending on the operating temperature. |
| Shaft seal: | Stuffing box or mechanical seal. |
| Flange connections: | Suction flange, according to DIN 2501 PN 16, Discharge flange, according to DIN 2501 PN 40 |
| Direction of rotation: | Clockwise, looking from the drive end. |

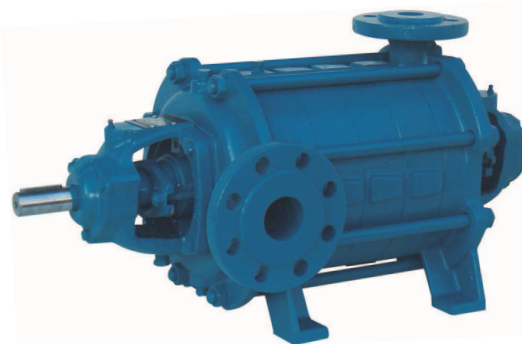

APPLICATION

Series HEG multistage centrifugal pumps are used in applications where the requirement is for trouble-free pumping of clear or slightly dirty liquids. They are used in:

- Heating plants
- Waterworks and water supply plants
- Pressure raising plants
- Circulating water and condensate plants
- Fire extinguishing plants
- Purification plants
- Irrigation plants
- Boiler feed water plants
- Pressurized water producing stations

DESIGN

Multistage horizontal centrifugal pumps with sectional casing and closed impellers.

The manufacturing program covers six sizes, with 2 up to maximum 13 stages, according to the size, the speed and the shaft seal. Axial thrust balancing is carried out by balancing the impellers separately. The remaining axial thrusts are taken up by adequately sized antifriction bearings.

The impellers, diffusers, as well as the wear ring from size 65, are interchangeable between stages.

Arrangements combining impellers of different diameters permit, within the application field, optimum matching to the required performance characteristics with the performance curve.

On the suction side, the mounting feet are arranged on the casing of the first stage. By this means, it is possible to ensure easy adaptation to different installation conditions, even subsequent to initial installation, by pivoting the suction head casing.

The driver is arranged on the suction side but discharge side driver or driver on both sides are possible on request.

All sizes can be supplied with one or more dummy stages, on request.

CONSTRUCTION

Casing pressure [bar]:

| Discharge casing | Suction casing | Temperature range ⁽¹⁾ |
|------------------|----------------|----------------------------------|
| max. 40 | max. 16 | -10 to 120 °C |
| max. 38 | max. 16 | up to 140 °C |
| max. 32,6 | max. 13 | up to 194 °C |

(1) Take in mind the application limit for the shaft seal

Discharge casing pressure = suction pressure + zero flow head.

NOTE: The relevant technical regulations and safety rules must be observed.

Flanges:

Suction side flange according to DIN 2533 PN16, discharge side flange according to DIN 2535 PN40.

The flanges can be drilled according to ANSI B16.1 class 250, on request.

Flange positions:

Suction flange arranged horizontally towards the right hand side (looking on the shaft end) and discharge vertical upwards.

On request, the suction flange can be arranged on the left and, in the case of pumps with three or more stages, also vertically upwards.

Bearings:

One cylindrical roller bearing according to DIN 5412 on the shaft end side and one deep-groove ball bearing according to DIN 625 on the discharge side, both lubricated by grease.

On request, two single row angular contact ball bearings, mounted in X arrangement, lubricated by grease, can be supplied on the discharge side.

Shaft sealing:

Sealing of the shaft can be carried out either by a stuffing box or mechanical seal as required.

- Designation 001:
Uncooled stuffing box.
Temperature range: -10 up to 110 °C.
- Designation 022:
Externally flushed, uncooled, lengthened stuffing box (nonavailable for sizes 25 and 32).
Temperature range: -10 o 110 °C.
- Designation 511:
Cooled stuffing box.
Temperature range: up to 140 °C (up to 194 °C to co nsult).
- Designation BK3/BKS/BKU:
Unbalanced single mechanical seal with rubber bellows and self-circulation.
Temperature range: -10 °C up to 110 °C
- Designation BX3/BXS/BXU:
Equivalent to BK3/BKS/BKU plus refrigeration/heating chamber.
Temperature range: up to 140 °C

Materials of construction:

| Item | Component | Material | | | | | Construction ⁽¹⁾ | | | | | | | | |
|-------|-----------------------------|--|---|---------------------|---------------|------|-----------------------------|----------------|----------------|----------------|-------------------|-------------------|-------------------|----------------|-------------------|
| | | Mat. Nr. | DIN denomination | ISO-EN denomination | US Material | | 0B | 0C | 0D | 0E | 0R ⁽²⁾ | 0S ⁽²⁾ | 0U ⁽²⁾ | 1B | 4B ⁽³⁾ |
| | | | | | ASTM | AISI | | | | | | | | | |
| 10.6 | Suction casing | 0.6025 | GG-25 | EN-GJL 250 | A278 Cl. 30 | | x | x | x | x | x | x | x | | |
| | | 0.7043 | GGG-40,3 | EN-GJS-400-18 | A395 | | | | | | | | | x | |
| | | 1.4408 | GX6CrNiMo18-10 | GX5CrNiMo19-11-2 | A351 CF8M | 316 | | | | | | | | | x |
| 10.7 | Discharge casing | 0.6025 | GG-25 | EN-GJL 250 | A278 Cl. 30 | | x | x | x | x | x | x | x | | |
| | | 0.7043 | GGG-40,3 | EN-GJS-400-18 | A395 | | | | | | | | | x | |
| | | 1.4408 | GX6CrNiMo18-10 | GX5CrNiMo19-11-2 | A351 CF8M | 316 | | | | | | | | | x |
| 10.8 | Stage casing | 0.6025 | GG-25 | EN-GJL 250 | A278 Cl. 30 | | x | x | x | x | x | x | x | | |
| | | 0.7043 | GGG-40,3 | EN-GJS-400-18 | A395 | | | | | | | | | x | |
| | | 1.4408 | GX6CrNiMo18-10 | GX5CrNiMo19-11-2 | A351 CF8M | 316 | | | | | | | | | x |
| 23.0 | Impeller | 0.6025 | GG-25 | EN-GJL 250 | A278 Cl. 30 | | x | | | | x | | | x | |
| | | 2.1060 | G-CuSn12 Ni | EN-CC484K | B427 C91700 | | | x | x | | | x | | | |
| | | 1.4408 | GX6CrNiMo18-10 | GX5CrNiMo19-11-2 | A351 CF8M | 316 | | | | x | | | x | | x |
| 17.1 | Diffuser | 0.6025 | GG-25 | EN-GJL 250 | A278 Cl. 30 | | x | x | | x | x | x | x | | |
| | | 2.1060 | G-CuSn12 Ni | EN-CC484K | B427 C91700 | | | | x | | | | | | |
| | | 1.4408 | GX6CrNiMo18-10 | GX5CrNiMo19-11-2 | A351 CF8M | 316 | | | | | | | | | x |
| 21.1 | Shaft ⁽⁴⁾ | 1.4021 | X20Cr 13 | X20Cr13 | A276 Gr. 420 | 420 | x ⁵ | x ⁵ | x ⁵ | x ⁵ | x ⁷ | x ⁷ | x ⁷ | x ⁵ | x ⁷ |
| | | 1.4401 | X5CrNiMo17-12-2 | X5CrNiMo17-12-2 | A276 Gr. 316 | 316 | | | | | x | x | x | | x |
| | | 1.7225 | 42 CrMo 4 | 42CrMo4 | A322 Gr. 4140 | 4140 | x ⁶ | x ⁶ | x ⁶ | x ⁶ | | | | | x ⁶ |
| 52.4 | Shaft sleeve (stuffing box) | 1.4021 | X20Cr 13 | X20Cr13 | A276 Gr. 420 | 420 | x | x | x | x | x | x | x | x | |
| | | 1.4401 | X5CrNiMo17-12-2 | X5CrNiMo17-12-2 | A276 Gr. 316 | 316 | | | | | | | | | x |
| 52.32 | Shaft sleeve (mec. seal) | 1.4021 | X20Cr 13 | X20Cr13 | A276 Gr. 420 | 420 | x | x | x | x | x | x | x | x | |
| | | 1.4401 | X5CrNiMo17-12-2 | X5CrNiMo17-12-2 | A276 Gr. 316 | 316 | | | | | | | | | x |
| 46.1 | Stuffing box | Synthetic fiber with PTFE impregnation | | | | | x | x | x | x | x | x | x | x | x |
| 43.3 | Mechanical seal | AQ1EGG | [Carbon graphite / Silicon carbide / EPDM] | | | | x | x | x | x | x | x | x | x | x |
| | | AQ1VGG | [Carbon graphite / Silicon carbide / Viton] | | | | | | | | | | | | |
| | | Q1Q1VGG | [Silicon carbide / Silicon carbide / Viton] | | | | | | | | | | | | |

- (1) Other combinations are possible. Please consult with the factory.
(2) Construction not available for pumps 3207/11, 5005/08 and 6504/06 running at 3000 or 3600 rpm. For pumps size 80 is only possible for maximum 1500 rpm.
(3) Construction not available for pumps size 80.
(4) Pumps with special shaft support (version: M), consult the factory for the appropriated shaft material, according to the pump application.
(5) For pumps size 80 only is possible for rotation speed up to 1500 rpm, or running at 1800 rpm and temperature lower than 50°C.
(6) Standard construction only for pumps size 80.
(7) Only for pumps 3207/11, 5005/08 and 6504/06, running at 3000 or 3600 rpm.

Casing gasket:

The casings are sealed by means of O-rings.
Temperatures up to 120 °C by means of NBR (Buna-N) O-rings. Code of this version: P.
Temperatures over 120 °C up to 190 °C by means of F KM (Viton®) O-rings. Code of this version: V.

Motor power, speed and number of stages:

By means of standard electrical motors, construction type IM B3.

To determine the motor power we recommend consider the following safety margins:

| | |
|---|-----|
| Up to 4 kW (5 HP): | 25% |
| Over 4 kW up to 7,5 kW (5 up to 10 HP): | 20% |
| Over 7,5 kW up to 40 kW (10 up to 50 HP): | 15% |
| Over 40 kW (50 HP): | 10% |

The following maximum numbers of stages as a function of shaft seal and speeds must be observed:

| Pump size | Maximum speed [rpm] | Maximum number of stages according to the shaft seal | | | | |
|-----------|------------------------|--|-----|-----|-------------|-------------|
| | | 001 | 022 | 511 | BK3/BKS/BKU | BX3/BXS/BXU |
| 2500 | 1 800 | 13 | - | 11 | 13 | 11 |
| | 3 000 | 11 | - | 11 | 13 | 11 |
| | 3 600 | 8 | - | 8 | 10 | 8 |
| 3200 | 1 800 | 12 | - | 10 | 12 | 10 |
| | 3 000 | 9 | - | 9 | 11 | 9 |
| | 3 600 | 6 | - | 6 | 7 | 6 |
| 4000 | 1 800 | 12 | 10 | 10 | 12 | 10 |
| | 3 000 | 8 | 8 | 8 | 9 | 8 |
| | 3 600 | 6 | 6 | 6 | 6 | 6 |
| 5000 | 1 800 | 11 | 9 | 9 | 11 | 9 |
| | 3 000 | 6 | 6 | 6 | 8 | 6 |
| | 3 600 | 4 | 4 | 4 | 5 | 4 |
| 6500 | 1 800 | 10 | 8 | 8 | 10 | 8 |
| | 3 000 | 5 | 5 | 5 | 6 | 5 |
| | 3 600 | 3 | 3 | 3 | 4 | 3 |
| 8000 | 1 800 | 9 | 7 | 7 | 9 | 7 |
| | 3 000 | 4 | 4 | 4 | 5 | 4 |
| | 3 600 | 2 | 2 | 2 | 3 | 2 |

General notes:

The following additional design is available:

HESB: Vertical multistage centrifugal pumps, base supported for casing pressures up to 25 bar.

Sectional drawing and list of parts

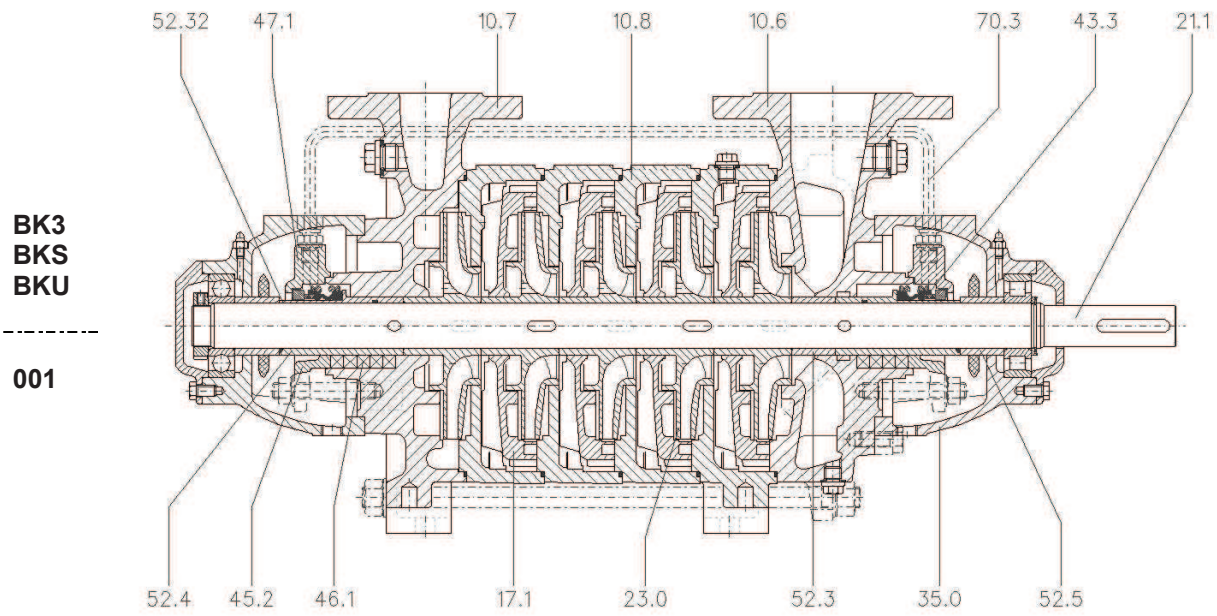

| | | | | | |
|------|------------------|------|----------------------|-------|-------------------------|
| 10.6 | Suction casing | 43.3 | Mechanical seal | 52.3 | Spacer sleeve |
| 10.7 | Discharge casing | 45.1 | Stuffing box housing | 52.31 | Spacer sleeve |
| 10.8 | Stage casing | 45.2 | Stuffing box gland | 52.32 | Shaft protection sleeve |
| 17.1 | Diffuser | 45.8 | Lantern ring | 52.4 | Shaft protection sleeve |
| 21.1 | Shaft | 46.1 | Stuffing box | 52.5 | Spacer sleeve |
| 23.0 | Impeller | 47.1 | Seal cover | 70.3 | Liquid circulating tube |
| 35.0 | Bearing housing | | | | |

Other types of shaft sealing arrangement:

Execution 022 ⁽¹⁾

Uncooled, lengthened stuffing box with external flushed.

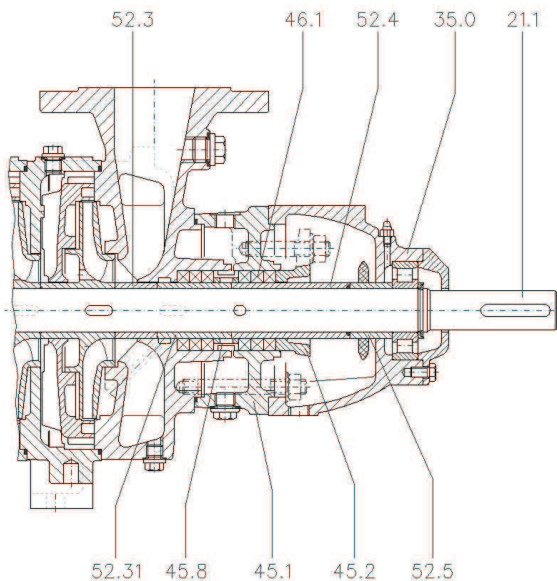

Execution 511 – Execution BX3/BXS/BXU

Cooled stuffing box – Refrigeration / Heating chamber.

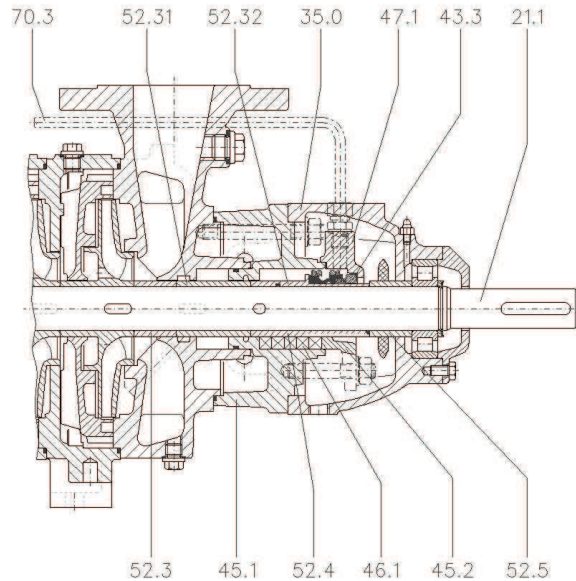

BX3
BXS
BXU

511

(1) Non-available for sizes 25 and 32

Field chart 50 Hz

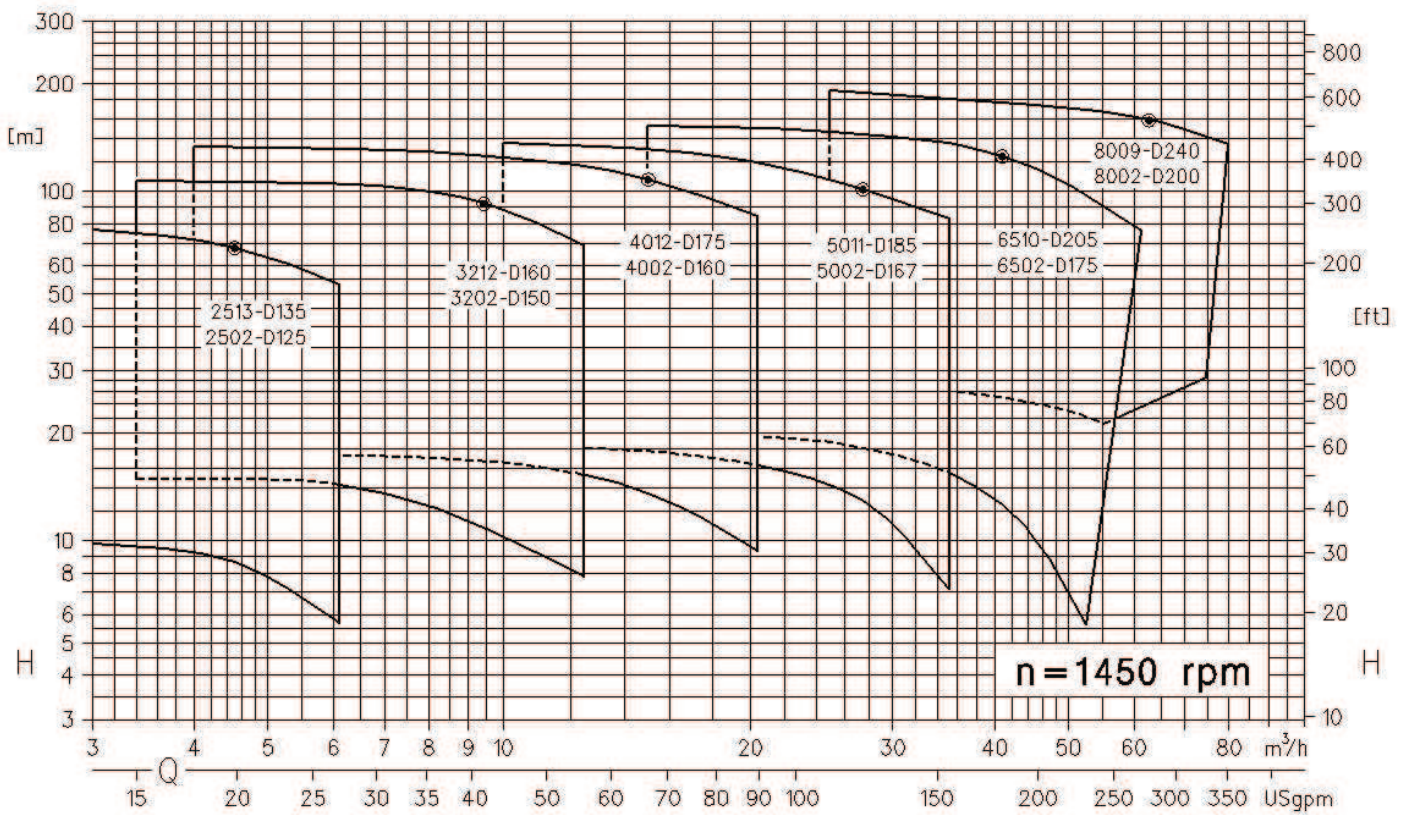
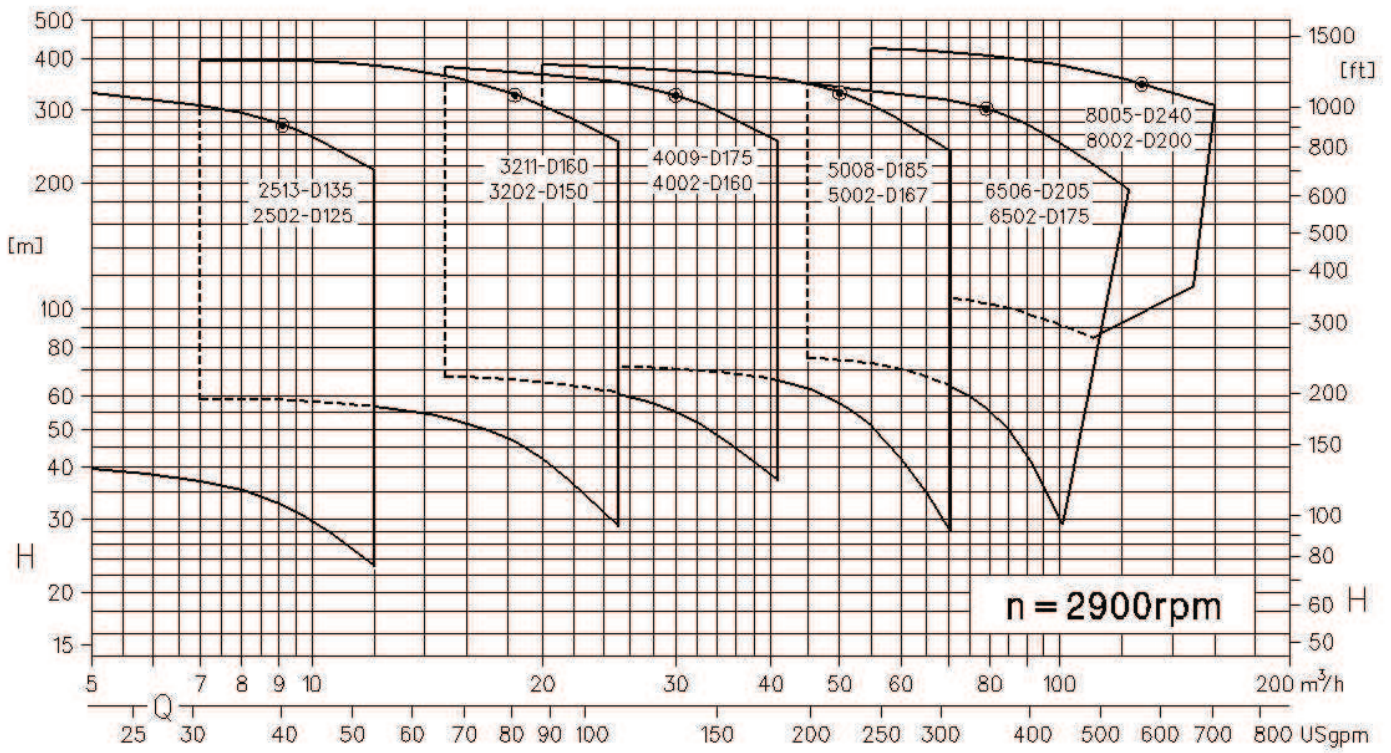

Field chart 60 Hz

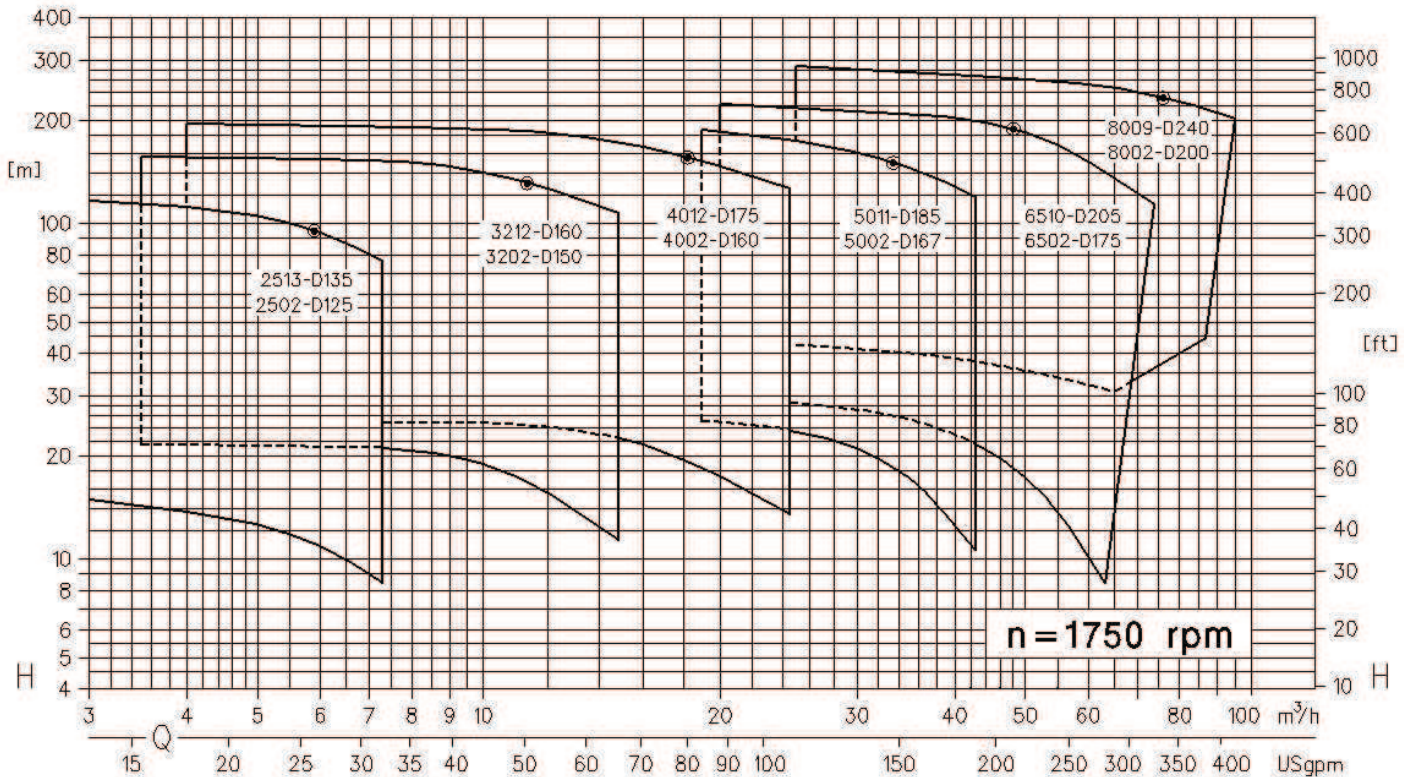
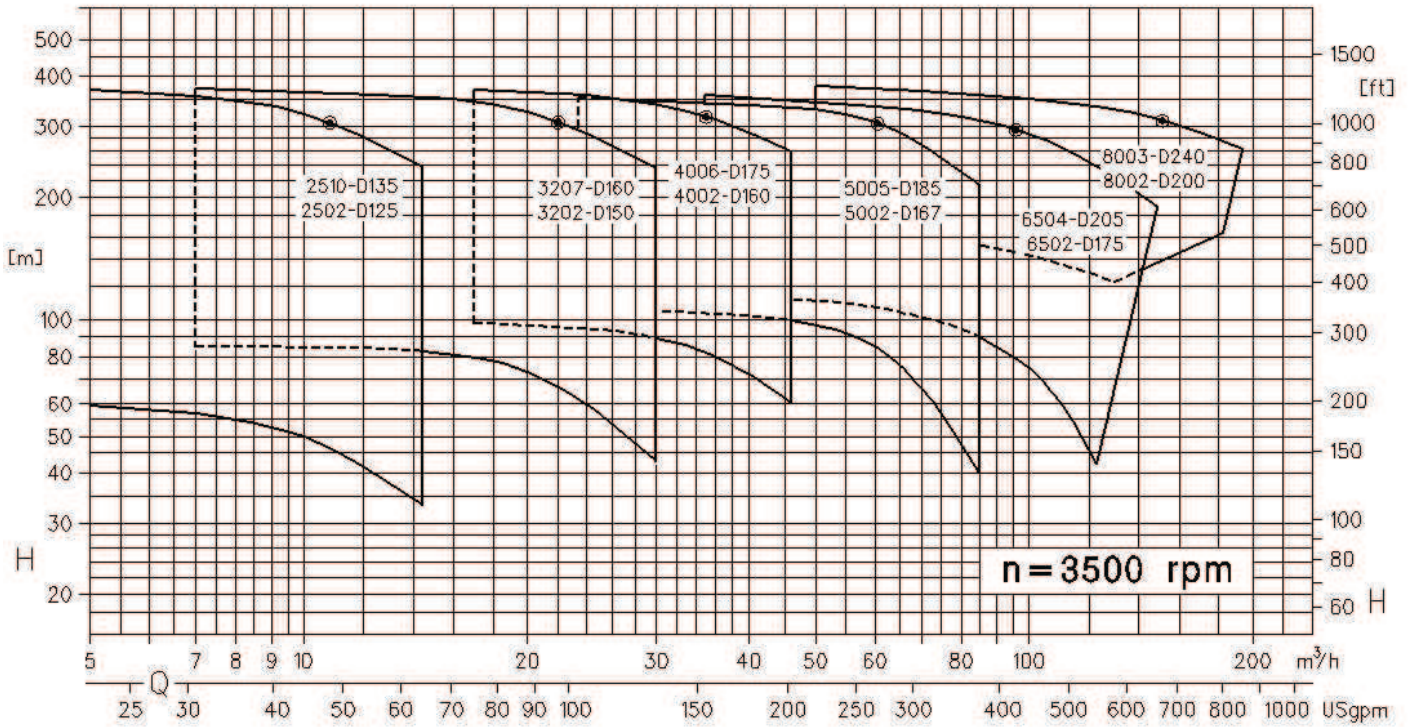

Performance curves

HEGA 25

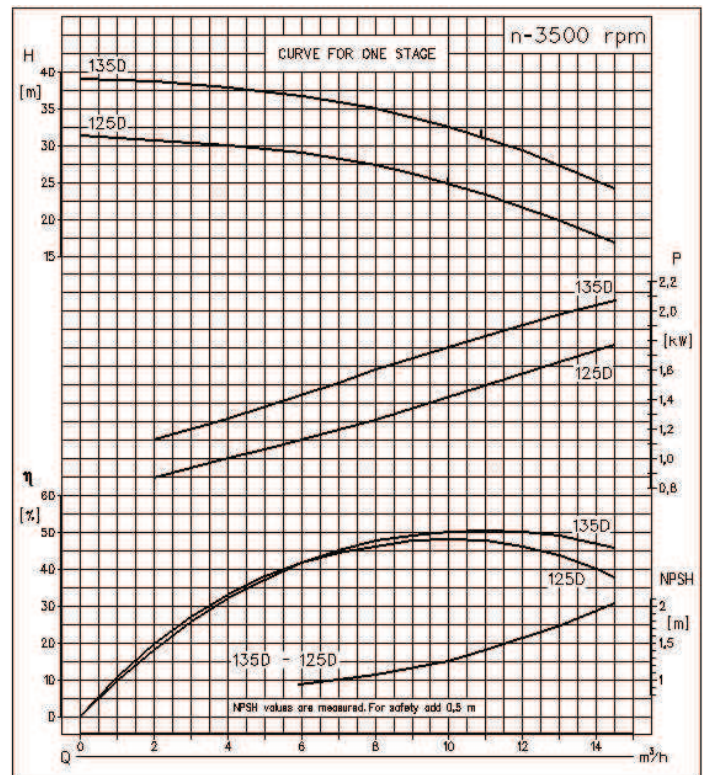
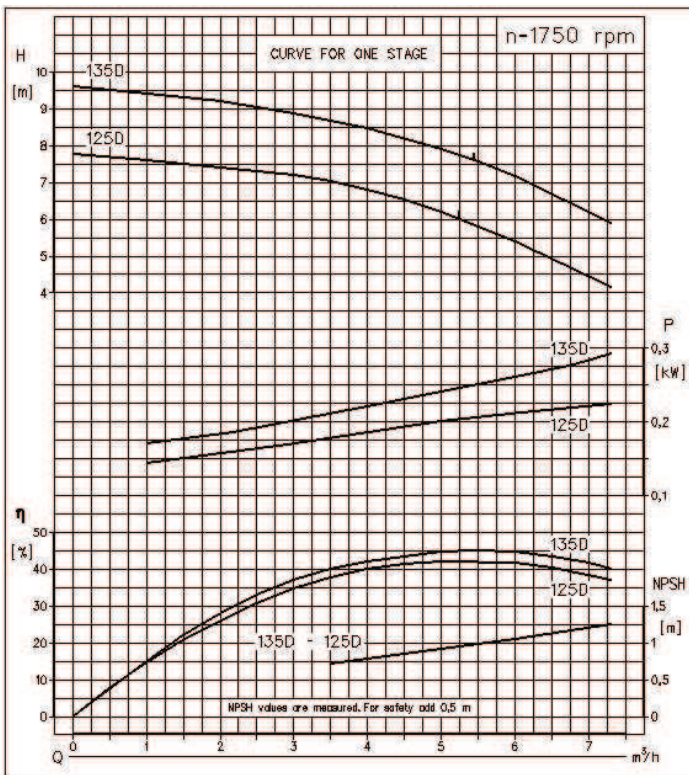
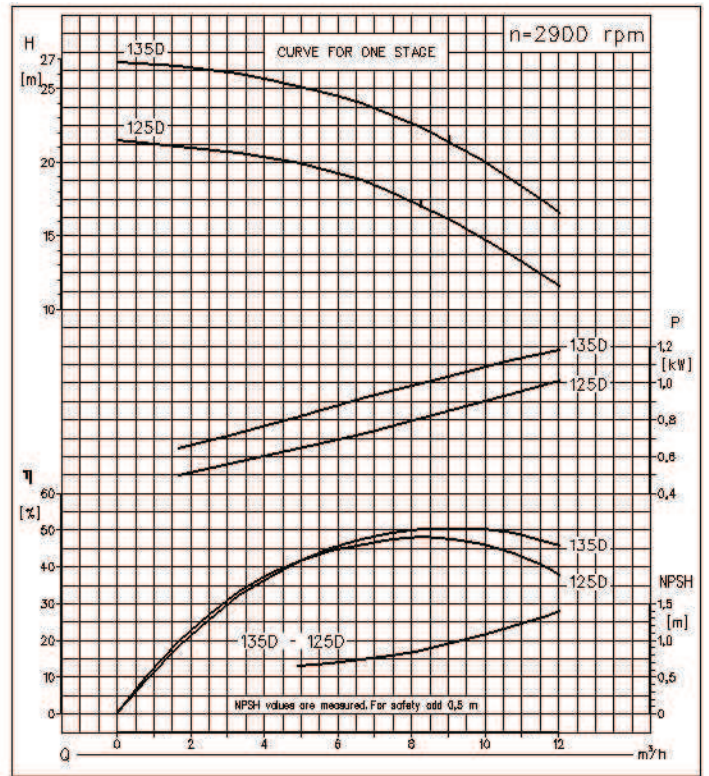
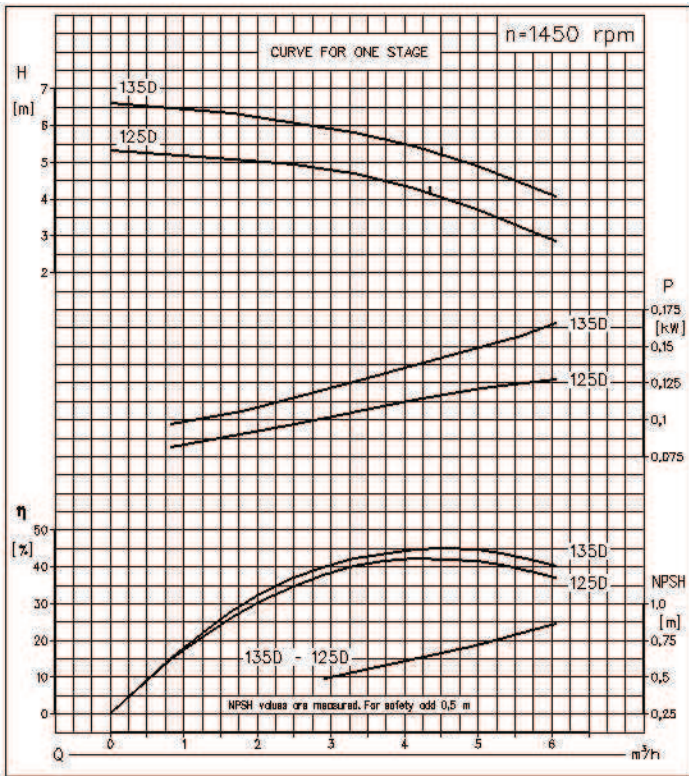

- Not valid for materials of construction 4B (stainless steel). Please consult with the factory.
- Head or Power for more than one stage = Head or Power for one stage multiplied by number of the stages.

Performance curves

HEGA 32

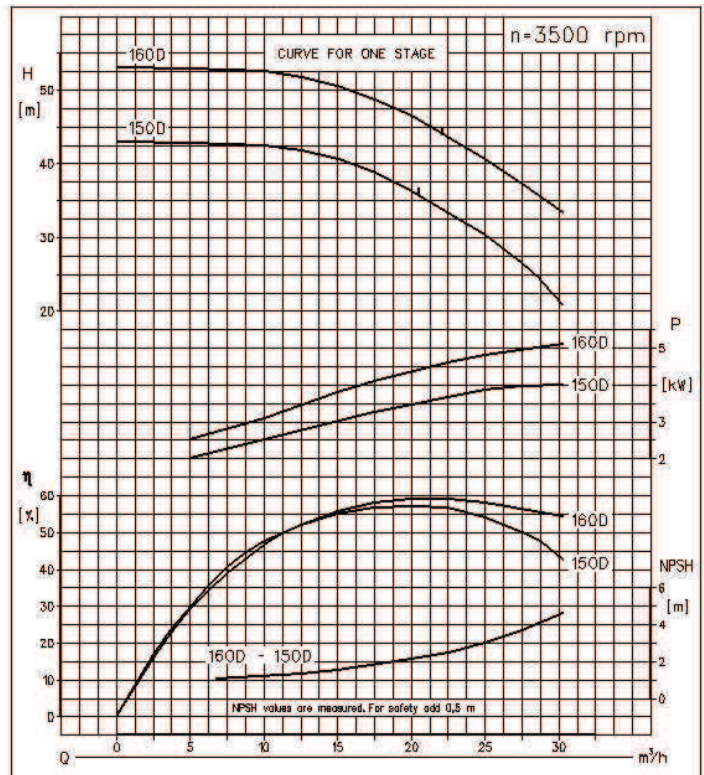
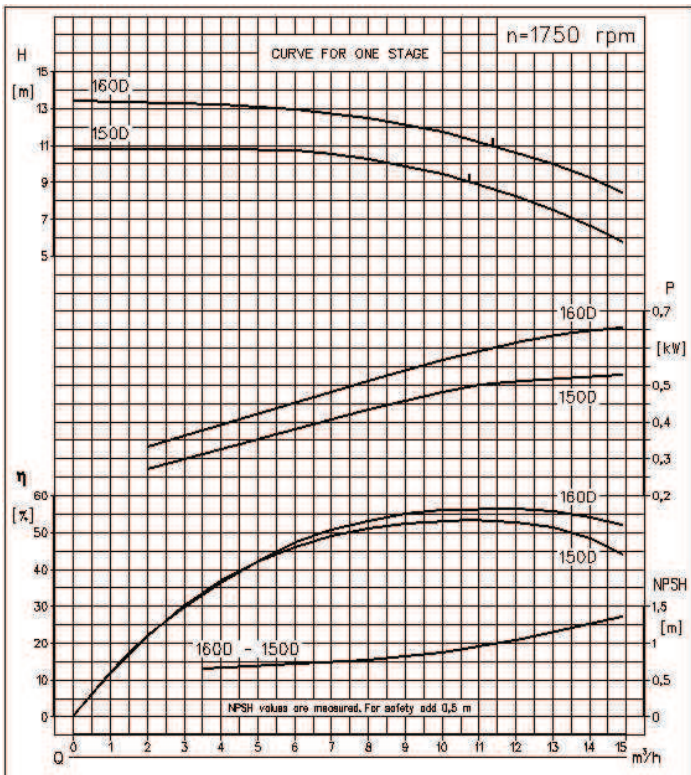
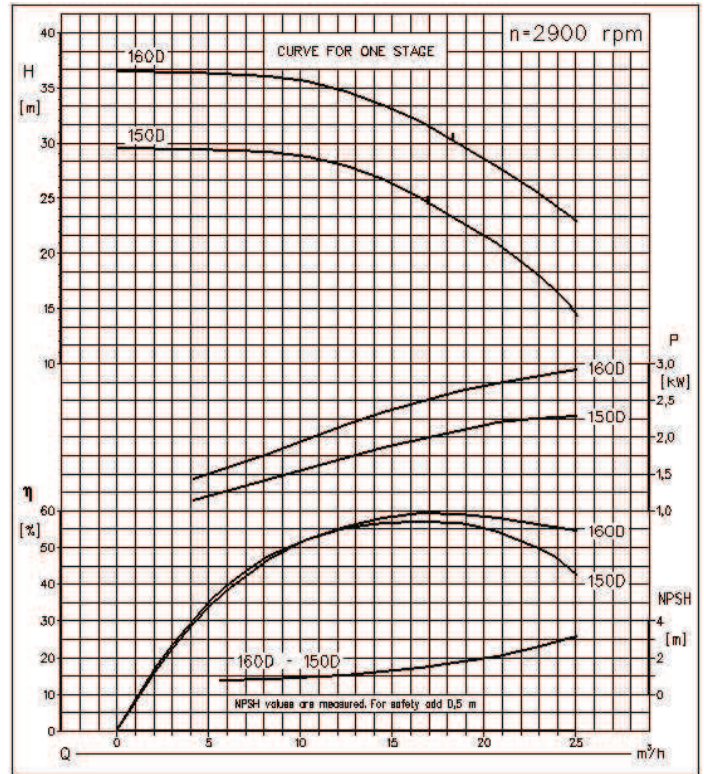
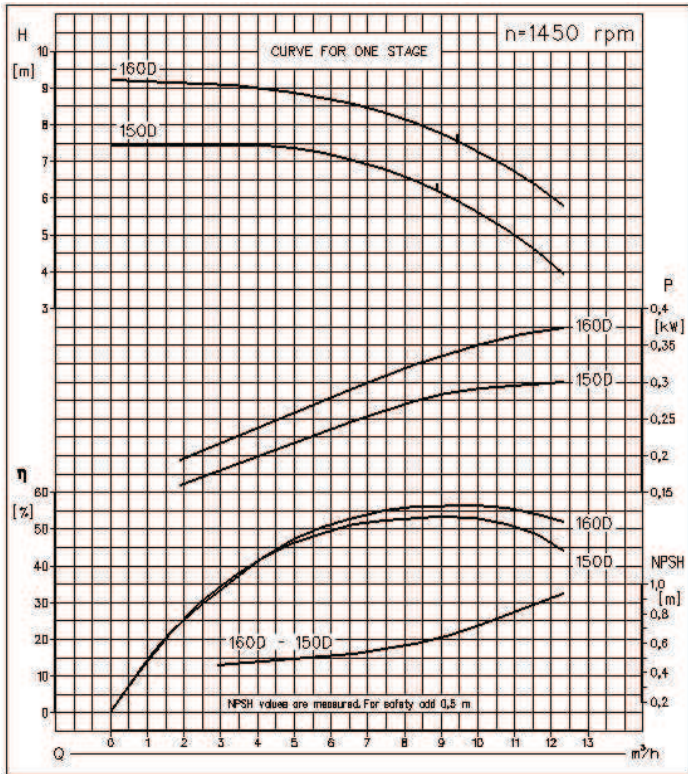

- Not valid for materials of construction 4B (stainless steel). Please consult with the factory.
- Head or Power for more than one stage = Head or Power for one stage multiplied by number of the stages.

Performance curves

HEGA 40

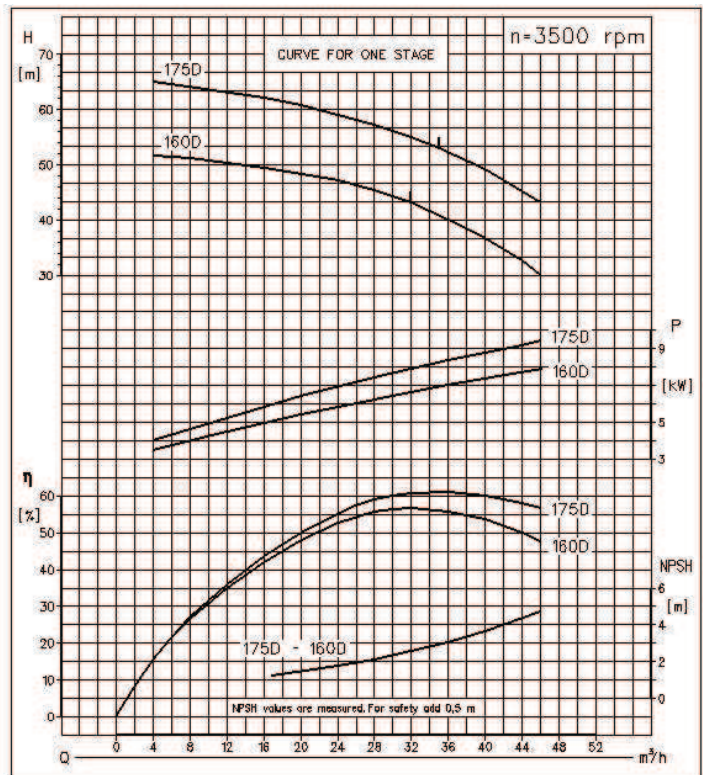
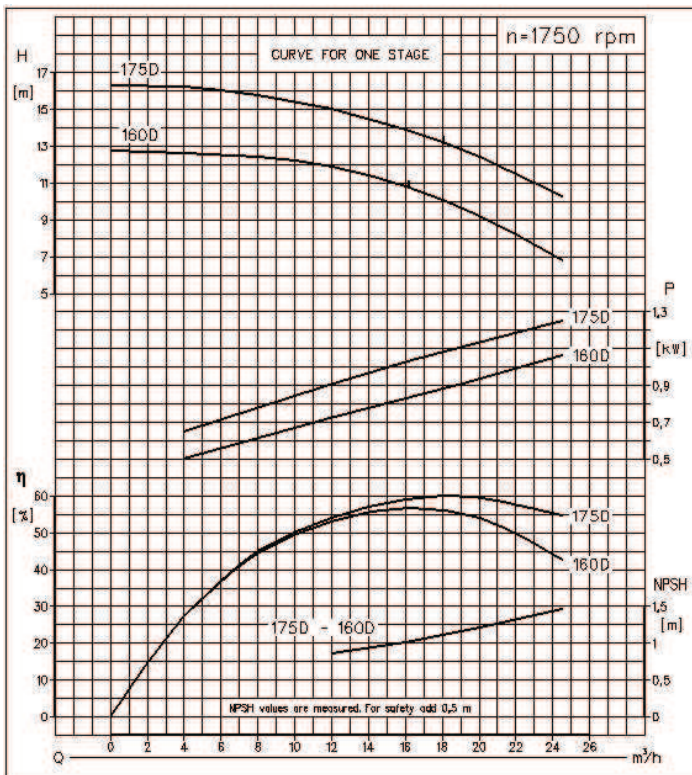
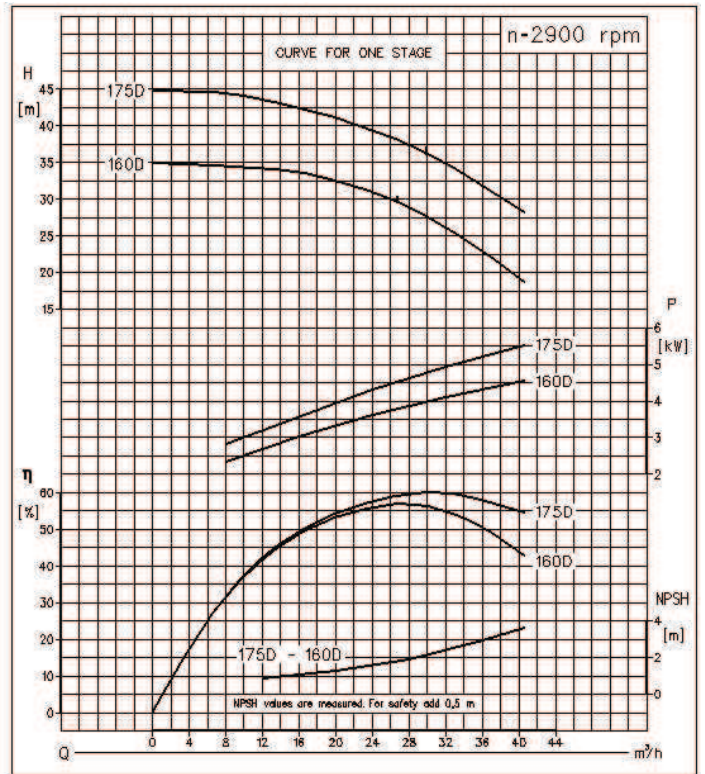
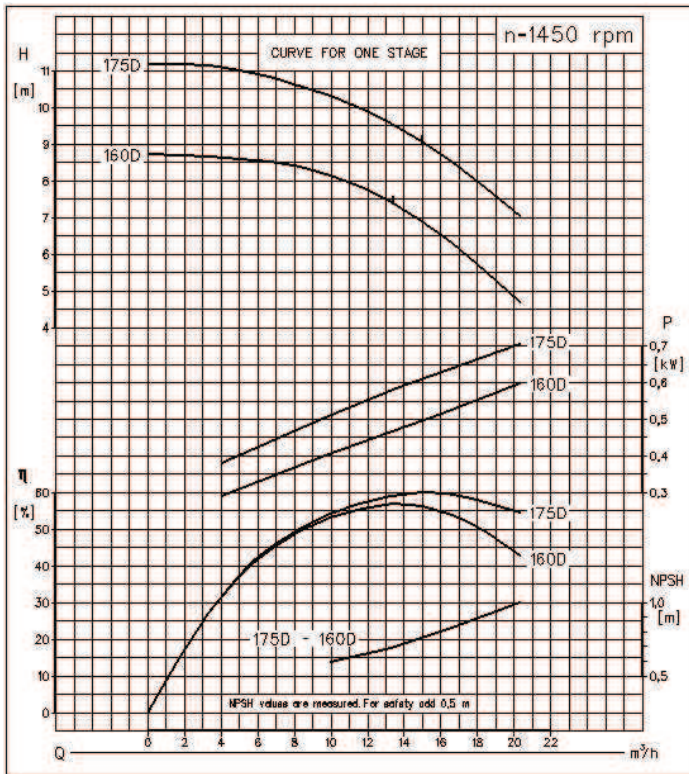

- Not valid for materials of construction 4B (stainless steel). Please consult with the factory.
- Head or Power for more than one stage = Head or Power for one stage multiplied by number of the stages.

Performance curves

HEGA 50

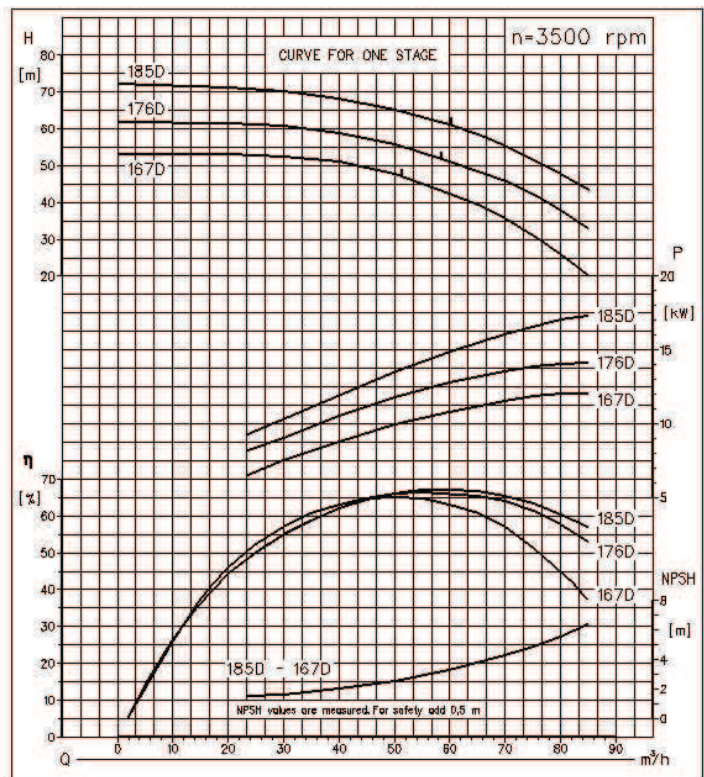
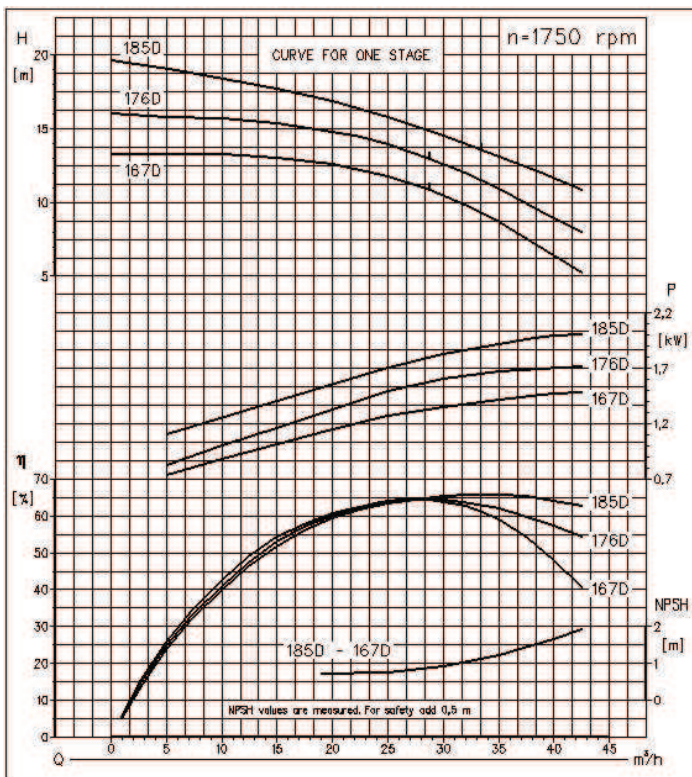
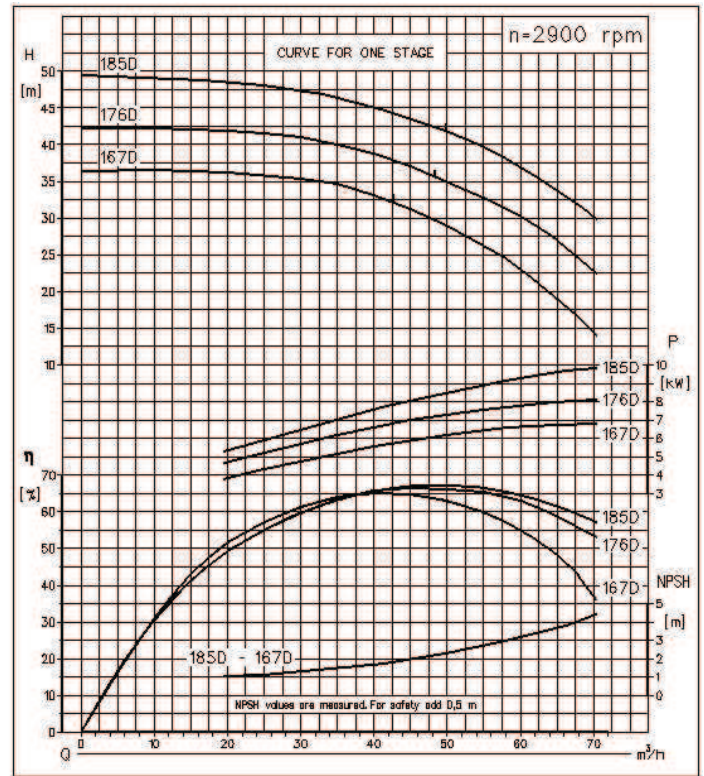
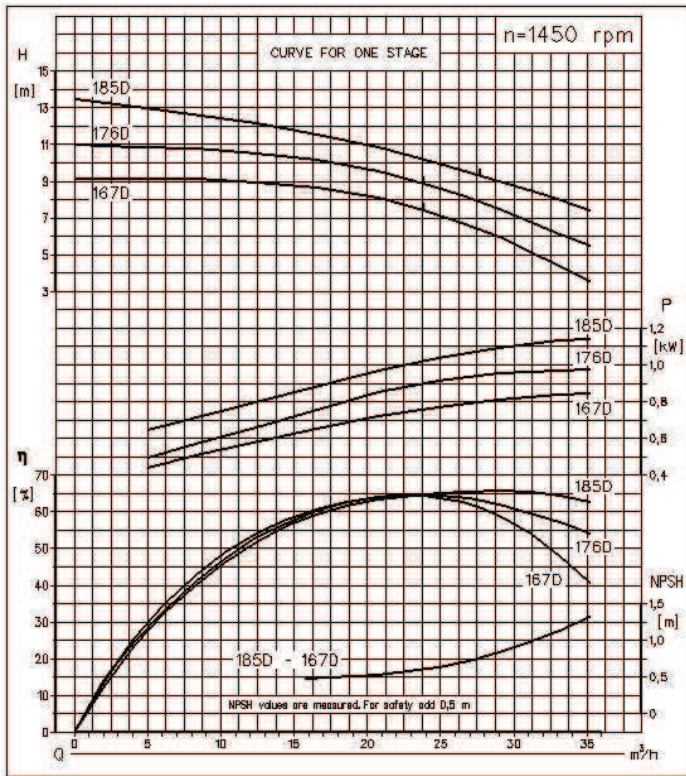

- Not valid for materials of construction 4B (stainless steel). Please consult with the factory.
- Head or Power for more than one stage = Head or Power for one stage multiplied by number of the stages.

Performance curves

HEGA 65

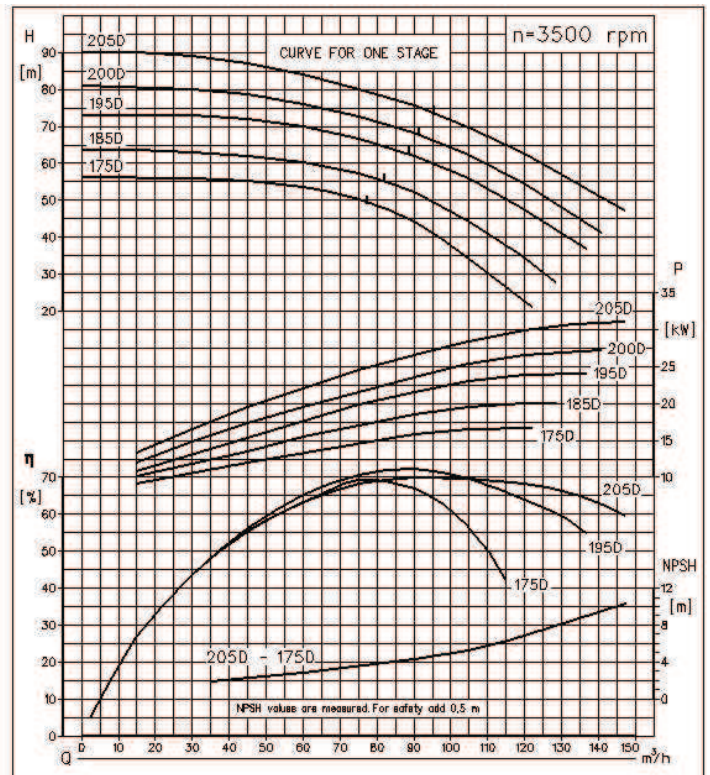
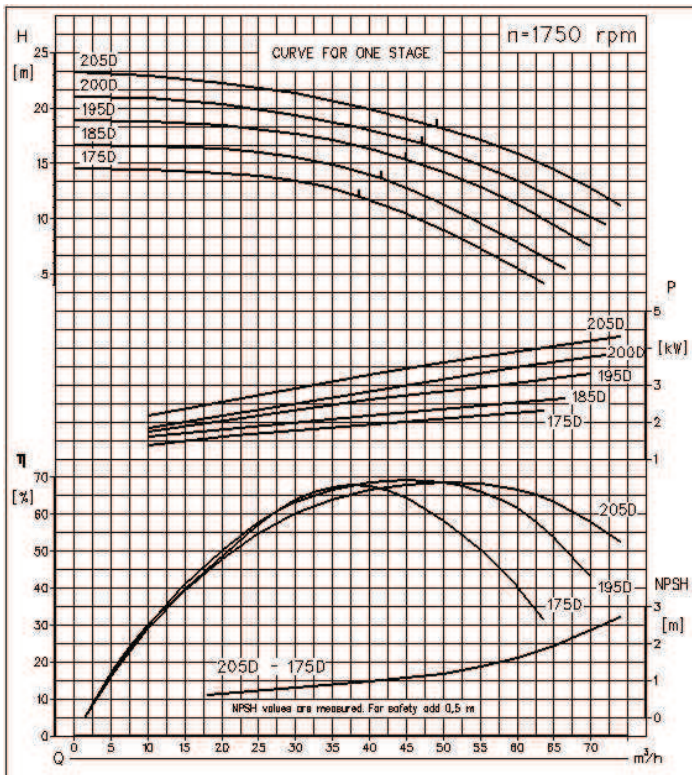
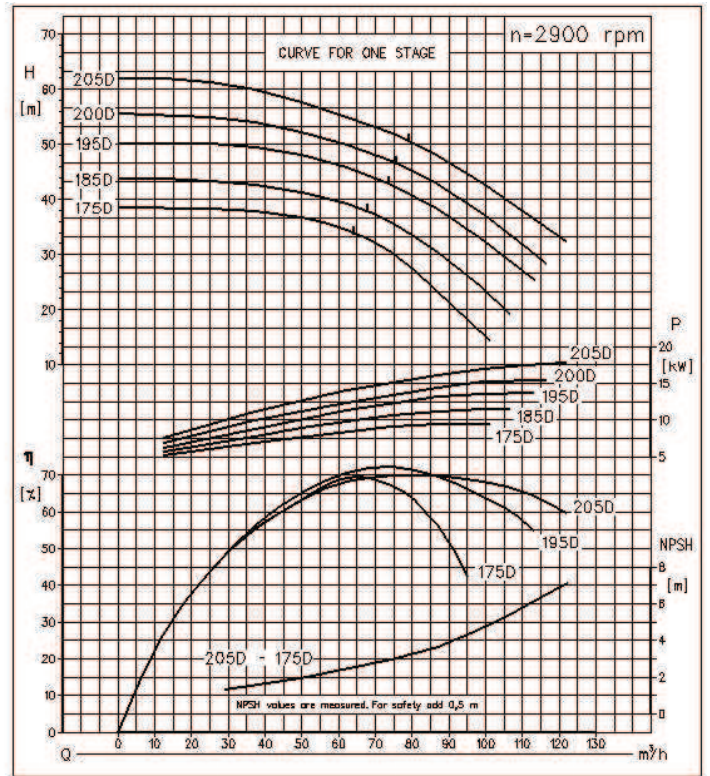
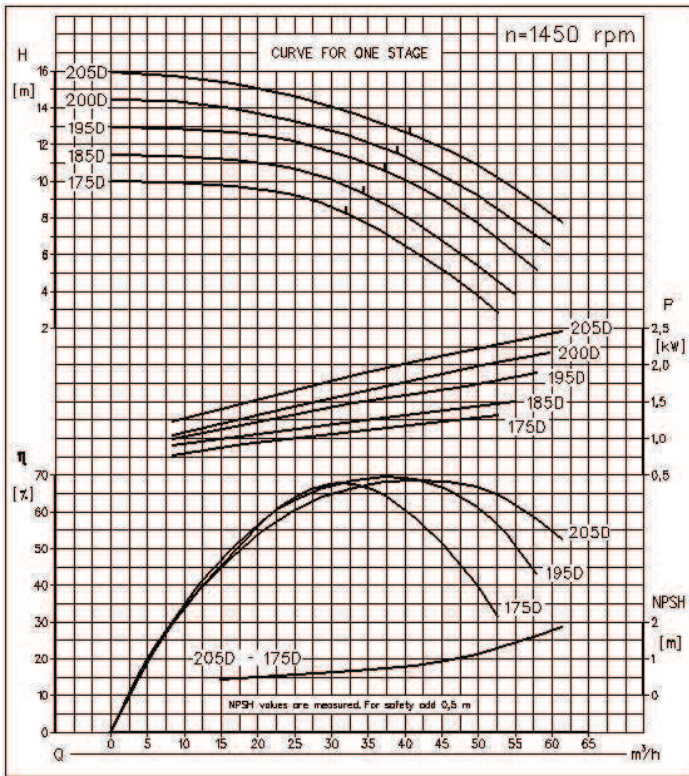

- Not valid for materials of construction 4B (stainless steel). Please consult with the factory.
- Head or Power for more than one stage = Head or Power for one stage multiplied by number of the stages.

Performance curves

HEGA 80

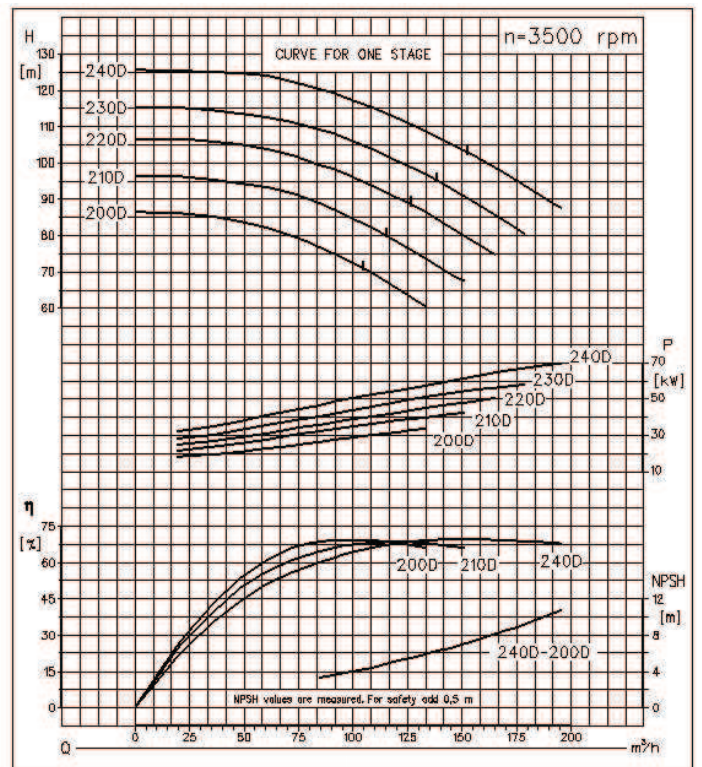
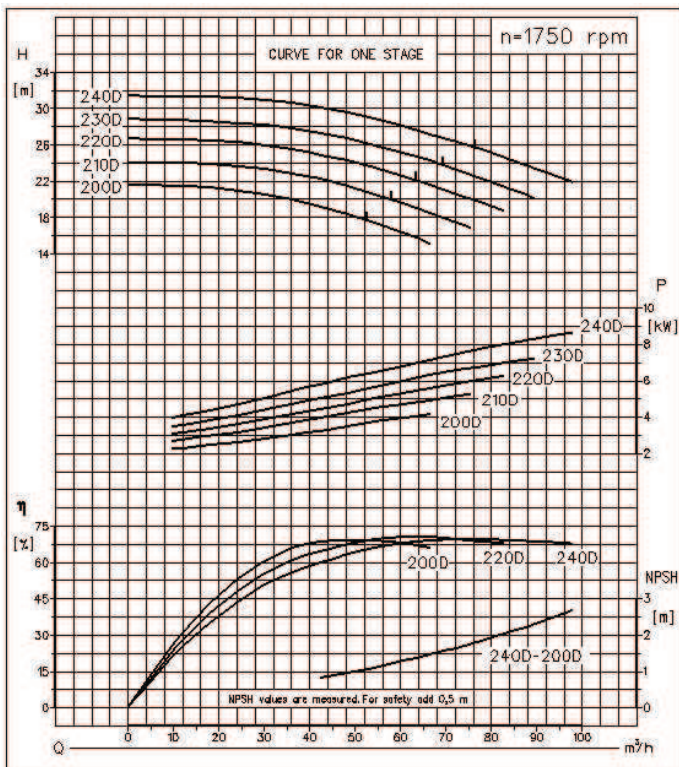
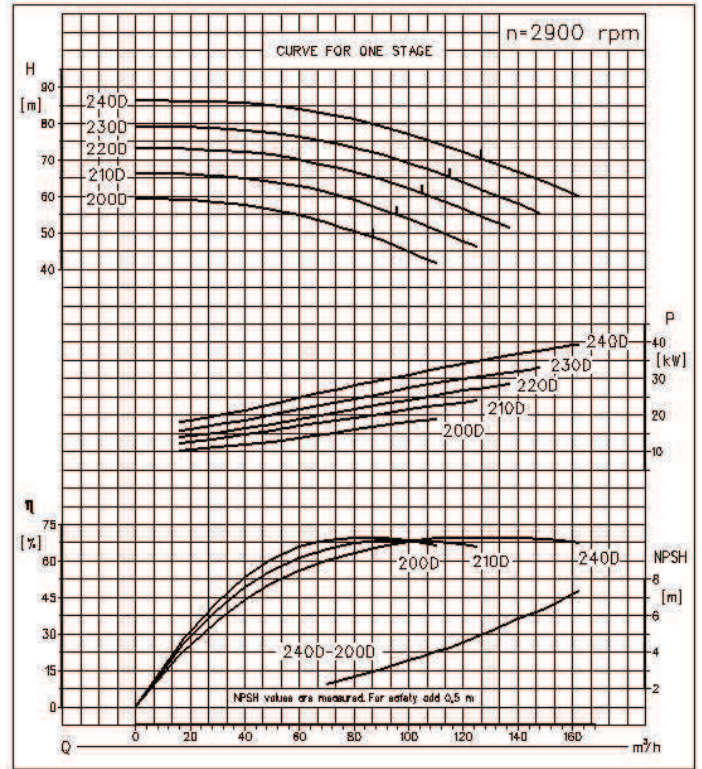
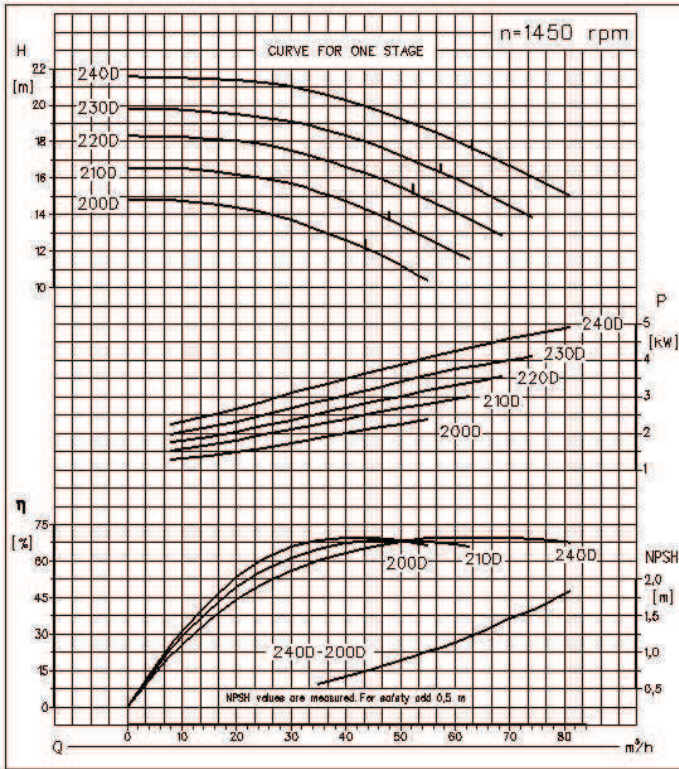

- Not valid for materials of construction 4B (stainless steel). Please consult with the factory.
- Head or Power for more than one stage = Head or Power for one stage multiplied by number of the stages.

Table of dimensions – shaft seal 001, BK3, BKS, BKU

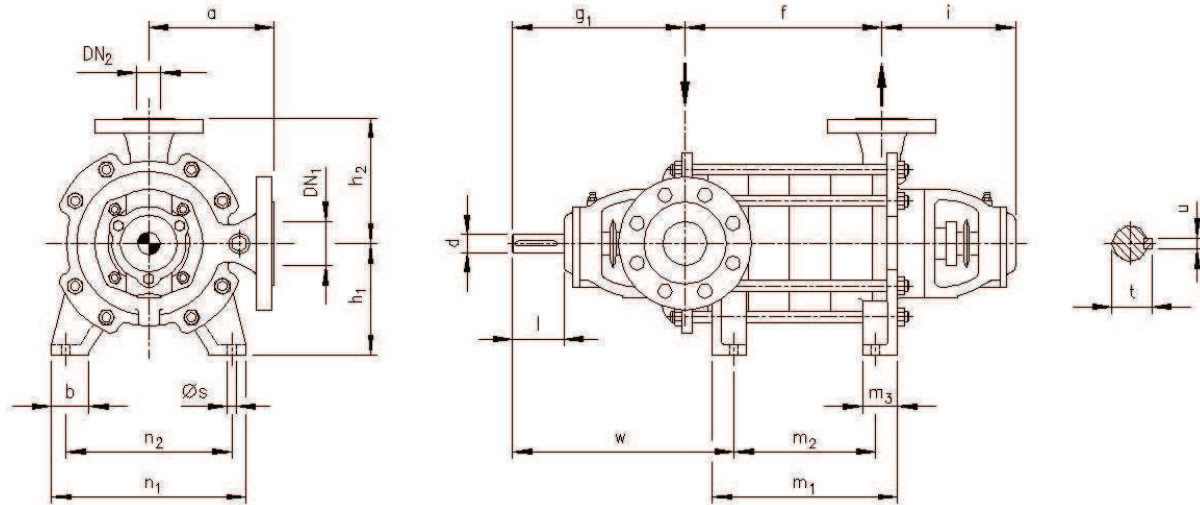

| Pump size | DN ₂ | DN ₁ | Pump dimensions | | | | | | Foot dimensions | | | | | | | Shaft end | | | | | |
|-----------|-----------------|-----------------|-----------------|----------------------------|----------------|----------------|----------------|-----|-----------------|----|----------------------------|----------------|----------------|----------------|----------------|-----------|-----|-----------------|------|---|------|
| | | | a | f | g ₁ | h ₁ | h ₂ | i | b | c | m ₁ | m ₂ | m ₃ | n ₁ | n ₂ | s | w | d _{k6} | l | t | u |
| 2500 | 32 | 40 | 160 | According to Nr. of stages | 243 | 132 | 160 | 173 | 45 | 12 | According to Nr. of stages | 45 | 250 | 216 | 15 | 293 | 28 | 60 | 30,9 | 8 | |
| 3200 | | 50 | 180 | | 230 | 180 | 295 | | | | | | | | | | | | | | |
| 4000 | 40 | 65 | 180 | | 265 | 160 | 180 | 193 | | | | 55 | 14 | 50 | 280 | 245 | 345 | 32 | 80 | | 35,3 |
| 5000 | 50 | 80 | 200 | | 275 | 200 | 216 | 55 | | | | 14 | 55 | 320 | 280 | 405 | 38 | 41,3 | | | |
| 6500 | 65 | 100 | 220 | | 300 | 180 | 220 | 216 | | | | 55 | 14 | 60 | 320 | 280 | 405 | 38 | 41,3 | | |
| 8000 | 80 | 100 | 250 | | 320 | 225 | 250 | 235 | | | | 60 | 16 | 70 | 370 | 320 | 20 | 440 | | | |

| Pump | 2500 | | | 3200 | | | 4000 | | | 5000 | | | 6500 | | | 8000 | | |
|------------------|------|----------------|----------------|------|----------------|----------------|------|----------------|----------------|------|----------------|----------------|------|----------------|----------------|------|----------------|----------------|
| Nr.stg. | f | m ₁ | m ₂ | f | m ₁ | m ₂ | f | m ₁ | m ₂ | f | m ₁ | m ₂ | f | m ₁ | m ₂ | f | m ₁ | m ₂ |
| 2 ⁽¹⁾ | 105 | 115 | 75 | 118 | 103 | 53 | 135 | 115 | 55 | 153 | 133 | 63 | 190 | 145 | 65 | 218 | 173 | 83 |
| 3 | 160 | 170 | 130 | 173 | 158 | 108 | 195 | 175 | 115 | 218 | 198 | 128 | 270 | 225 | 145 | 313 | 268 | 178 |
| 4 | 215 | 225 | 185 | 228 | 213 | 163 | 255 | 235 | 175 | 283 | 263 | 193 | 350 | 305 | 225 | 408 | 363 | 273 |
| 5 | 270 | 280 | 240 | 283 | 268 | 218 | 315 | 295 | 235 | 348 | 328 | 258 | 430 | 385 | 305 | 503 | 458 | 368 |
| 6 | 325 | 335 | 295 | 338 | 323 | 273 | 375 | 355 | 295 | 413 | 393 | 323 | 510 | 465 | 385 | 598 | 553 | 463 |
| 7 | 380 | 390 | 350 | 393 | 378 | 328 | 435 | 415 | 355 | 478 | 458 | 388 | 590 | 545 | 465 | 693 | 648 | 558 |
| 8 | 435 | 445 | 405 | 448 | 433 | 383 | 495 | 475 | 415 | 543 | 523 | 453 | 670 | 625 | 545 | 788 | 743 | 653 |
| 9 | 490 | 500 | 460 | 503 | 488 | 438 | 555 | 535 | 475 | 608 | 588 | 518 | 750 | 705 | 625 | 883 | 838 | 748 |
| 10 | 545 | 555 | 515 | 558 | 543 | 493 | 615 | 595 | 535 | 673 | 653 | 583 | 830 | 785 | 705 | | | |
| 11 | 600 | 610 | 570 | 613 | 598 | 548 | 675 | 655 | 595 | 738 | 718 | 648 | | | | | | |
| 12 | 655 | 665 | 625 | 668 | 653 | 603 | 735 | 715 | 655 | | | | | | | | | |
| 13 | 710 | 720 | 680 | | | | | | | | | | | | | | | |

| Flange dimensions according to DIN 2501 | | | | | | |
|--|--------|--------|--------|--------|--------|--------|
| DN ₂ / DN ₁ | 32 | 40 | 50 | 65 | 80 | 100 |
| Ø D | 140 | 150 | 165 | 185 | 200 | 220 |
| Ø k | 100 | 110 | 125 | 145 | 160 | 180 |
| d ₂ x cant. | PN 16 | 18 x 4 | 18 x 4 | 18 x 4 | 18 x 4 | 18 x 8 |
| | PN 40 | | | | 18 x 8 | |
| Flange drilled according to ANSI B16.1 cl. 250 | | | | | | |
| DN ₂ / DN ₁ | 1,1/4" | 1,1/2" | 2" | 2,1/2" | 3" | 4" |
| Ø k | 98 | 114 | 127 | 149 | 168 | 200 |
| d ₂ x cant. | 19 x 4 | 22 x 4 | 19 x 8 | 22 x 8 | 22 x 8 | 22 x 8 |

(1) Suction flange vertically upwards only from three stages onward.

Table of dimensions – shaft seal 022⁽¹⁾, 511, BX3, BXS, BXU

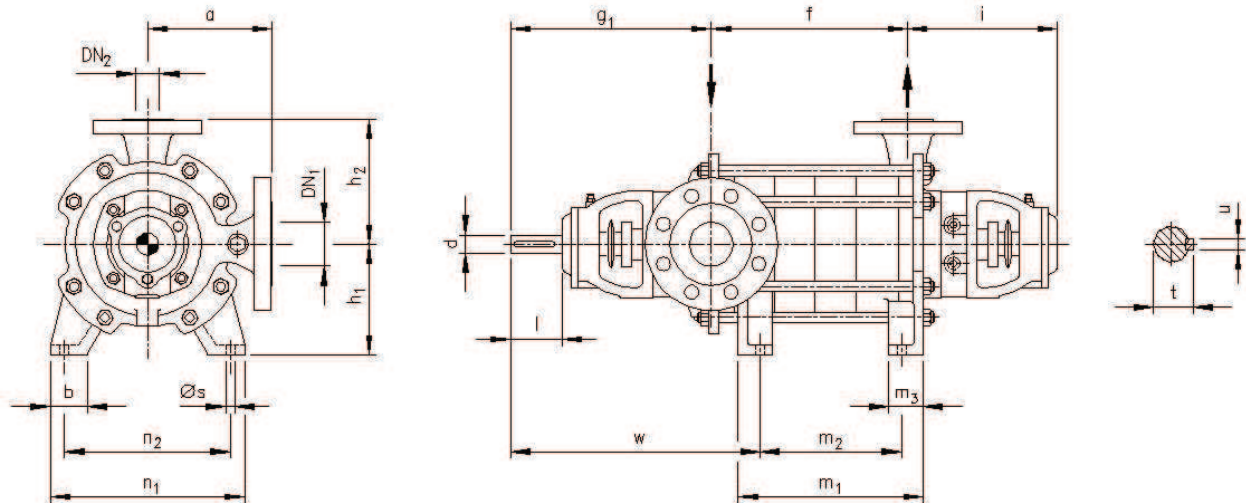

| Pump size | DN ₂ | DN ₁ | Pump dimensions | | | | | | Foot dimensions | | | | | | | Shaft end | | | | | | |
|-----------|-----------------|-----------------|-----------------|----------------------------|----------------|----------------|----------------|-----|-----------------|----|----------------------------|----------------|----------------|----------------|----------------|-----------|-----|-----------------|------|---|----|------|
| | | | a | f | g ₁ | h ₁ | h ₂ | i | b | c | m ₁ | m ₂ | m ₃ | n ₁ | n ₂ | s | w | d _{k6} | l | t | u | |
| 2500 | 32 | 40 | 160 | According to Nr. of stages | 298 | 132 | 160 | 228 | 45 | 12 | According to Nr. of stages | 45 | 250 | 216 | 15 | 348 | 28 | 60 | 30,9 | 8 | | |
| 3200 | | 50 | 180 | | 285 | 160 | 180 | | | | | | 253 | 350 | | | | | | | | |
| 4000 | 40 | 65 | | | 325 | | 200 | | | | | | 258 | 405 | | 32 | | | | | 80 | 35,3 |
| 5000 | 50 | 80 | 200 | | 340 | 220 | 296 | 55 | | | | | 14 | 55 | 320 | | 280 | 430 | | | | |
| 6500 | 65 | 100 | 220 | | 380 | 180 | 220 | 296 | | | | | 55 | 14 | 60 | 320 | 280 | 485 | 38 | | 80 | 41,3 |
| 8000 | 80 | 100 | 250 | | 415 | 225 | 250 | 330 | | | | | 60 | 16 | 70 | 370 | 320 | 20 | | | | |

| Pump | 2500 | | | 3200 | | | 4000 | | | 5000 | | | 6500 | | | 8000 | | |
|------------------|------|----------------|----------------|------|----------------|----------------|------|----------------|----------------|------|----------------|----------------|------|----------------|----------------|------|----------------|----------------|
| Nr.stg. | f | m ₁ | m ₂ | f | m ₁ | m ₂ | f | m ₁ | m ₂ | f | m ₁ | m ₂ | f | m ₁ | m ₂ | f | m ₁ | m ₂ |
| 2 ⁽²⁾ | 105 | 115 | 75 | 118 | 103 | 53 | 135 | 115 | 55 | 153 | 133 | 63 | 190 | 145 | 65 | 218 | 173 | 83 |
| 3 | 160 | 170 | 130 | 173 | 158 | 108 | 195 | 175 | 115 | 218 | 198 | 128 | 270 | 225 | 145 | 313 | 268 | 178 |
| 4 | 215 | 225 | 185 | 228 | 213 | 163 | 255 | 235 | 175 | 283 | 263 | 193 | 350 | 305 | 225 | 408 | 363 | 273 |
| 5 | 270 | 280 | 240 | 283 | 268 | 218 | 315 | 295 | 235 | 348 | 328 | 258 | 430 | 385 | 305 | 503 | 458 | 368 |
| 6 | 325 | 335 | 295 | 338 | 323 | 273 | 375 | 355 | 295 | 413 | 393 | 323 | 510 | 465 | 385 | 598 | 553 | 463 |
| 7 | 380 | 390 | 350 | 393 | 378 | 328 | 435 | 415 | 355 | 478 | 458 | 388 | 590 | 545 | 465 | 693 | 648 | 558 |
| 8 | 435 | 445 | 405 | 448 | 433 | 383 | 495 | 475 | 415 | 543 | 523 | 453 | 670 | 625 | 545 | 788 | 743 | 653 |
| 9 | 490 | 500 | 460 | 503 | 488 | 438 | 555 | 535 | 475 | 608 | 588 | 518 | 750 | 705 | 625 | 883 | 838 | 748 |
| 10 | 545 | 555 | 515 | 558 | 543 | 493 | 615 | 595 | 535 | 673 | 653 | 583 | 830 | 785 | 705 | | | |
| 11 | 600 | 610 | 570 | 613 | 598 | 548 | 675 | 655 | 595 | 738 | 718 | 648 | | | | | | |
| 12 | 655 | 665 | 625 | 668 | 653 | 603 | 735 | 715 | 655 | | | | | | | | | |
| 13 | 710 | 720 | 680 | | | | | | | | | | | | | | | |

| Flange dimensions according to DIN 2501 | | | | | | |
|--|--------|--------|--------|--------|--------|--------|
| DN ₂ / DN ₁ | 32 | 40 | 50 | 65 | 80 | 100 |
| Ø D | 140 | 150 | 165 | 185 | 200 | 220 |
| Ø k | 100 | 110 | 125 | 145 | 160 | 180 |
| d ₂ x cant. | PN 16 | 18 x 4 | 18 x 4 | 18 x 4 | 18 x 4 | 18 x 8 |
| | PN 40 | | | | 18 x 8 | |
| Flange drilled according to ANSI B16.1 cl. 250 | | | | | | |
| DN ₂ / DN ₁ | 1,1/4" | 1,1/2" | 2" | 2,1/2" | 3" | 4" |
| Ø k | 98 | 114 | 127 | 149 | 168 | 200 |
| d ₂ x cant. | 19 x 4 | 22 x 4 | 19 x 8 | 22 x 8 | 22 x 8 | 22 x 8 |

- (1) Non available for sizes 25 and 32
- (2) Suction flange vertically upwards only from three stages onward

Connections

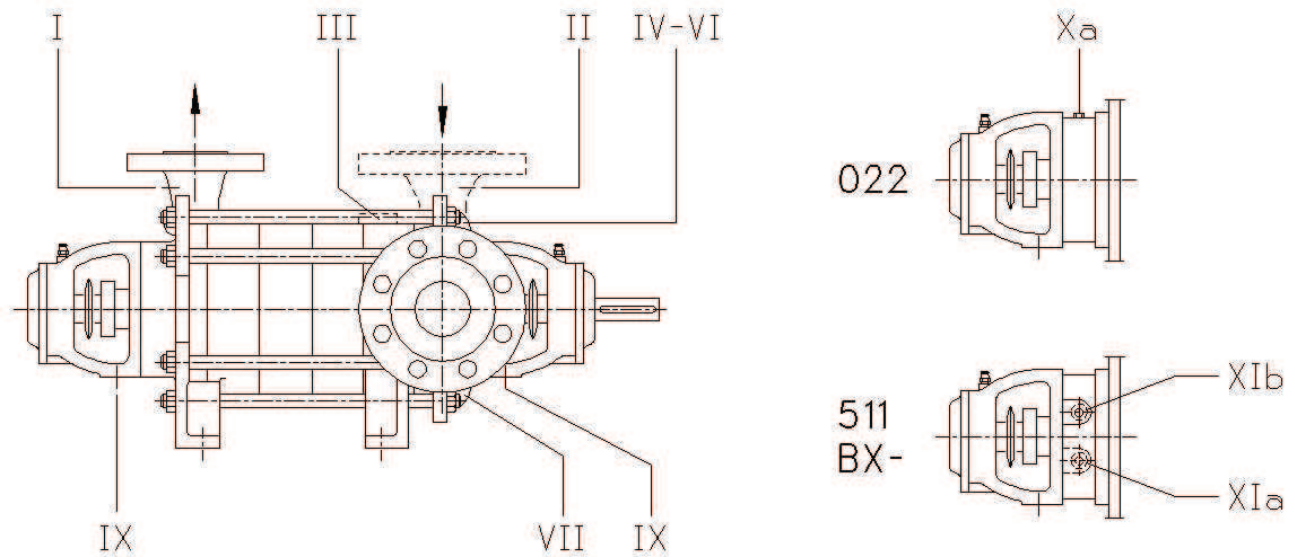

| Code | Connections | Shaft seal | Position of connections | Dimensions | |
|-------------------|--|---------------------------------|--|-------------|-------------|
| | | | | 2500 - 5000 | 6500 - 8000 |
| I | Pressure gauge connection | 001 022 511 BK- BX- | Discharge flange | G1/2" | G1/2" |
| II | Pressure / vacuum gauge connection | | Suction flange | G1/2" | G1/2" |
| III | Vent | | First stage casing | G1/4" | G3/8" |
| IV ⁽¹⁾ | Vent | | Suction casing | G1/4" | G3/8" |
| VI ⁽¹⁾ | Filler connection | | Suction casing | G1/4" | G3/8" |
| VII | Drain | | Suction casing | G1/4" | G3/8" |
| IX | Drip and leakage connection | | Bearing suction (suction and discharge side) | G3/8" | G1/2" |
| Xa | Connection for sealing liquid | 022 | Stuffing box housing (suction and discharge side) | G3/8" | G1/2" |
| XIa | Inlet connection for shaft seal cooling | 511 BX- | Stuffing box housing (suction and discharge side) | G3/8" | G1/2" |
| XIb | Outlet connection for shaft seal cooling | | Stuffing box housing (suction and discharge side) | G3/8" | G1/2" |

(1) When suction flange position is horizontal, to right or to left.

Denomination – Instructions for ordering

The table describes the codification for the pump denomination according to its execution.

| Type, size and number of stages | Impeller combination | Hydraulic and shaft support | Shaft sealing | Materials of construction | Casing gasket | Drive, standard and orientation of the flanges (always seen from shaft end) |
|--|--|---|---|--|--|---|
| HEGA 02502 - 02513 03202 - 03212 04002 - 04012 05002 - 05011 06502 - 06510 08002 - 08009 | 0-4 0-4 0-4 0-7 0/9 0/9 | A • Hydraulic A | 001 Uncooled stuffing box. | 0B Main parts of cast iron | P O-rings of NBR ⁽³⁾ (Perbunan) | DRIVE ON SUCTION SIDE: 0 DIN/EN flanges, discharge vertical up, suction horizontal right. 1 Same as 0, but suction horizontal left. 2 Same as 0, but suction vertical up. (only for more than 3 stages) A Same as 0, but flanges drilled according to ANSI. B Same as 1, but flanges drilled according to ANSI. C Same as 2, but flanges drilled according to ANSI. DRIVE ON DISCHARGE SIDE (only for sizes 25, 32 and 40): 3 DIN/EN flanges, discharge vertical up, suction horizontal left. 4 Same as 3, but suction horizontal right. 5 Same as 3, but suction vertical up. (only for more than 3 stages) D Same as 3, but flanges drilled according to ANSI. E Same as 4, but flanges drilled according to ANSI. F Same as 5, but flanges drilled according to ANSI. |
| | | B • Hydraulic B ⁽¹⁾ | 022 Externally flushed, uncooled, lengthened stuffing box (only for sizes 40, 50 and 65). | 0C Same as 0B but impellers in bronze | V O-rings of FKM ⁽³⁾ (Viton ®) | |
| | | • B One cylindrical roller bearing (DIN 5412) on the suction side and one deep-groove ball bearing (DIN 625) on the discharge side; both lubricated by grease. | 511 Cooled stuffing box. | 0D Same as 0C but diffusers and wear rings in bronze | | |
| | | • M One cylindrical roller bearing (DIN 5412) on the suction side and two single row angular contact ball bearings mounted in X arrangement on the discharge side; both lubricated by grease. | BK • Unbalanced mechanical seal with rubber bellows. Material code of mechanical seal ⁽²⁾ •• 3 AQ1EGG •• U AQ1VGG •• S Q1Q1VGG | 0E Same as 0B but impellers in stainless steel | | |
| | | | BX3 Equivalent to BK3/BKS/BKU plus refrigeration or heating chamber BXU BXS | 0R Same as 0B but shaft in stainless steel | | |
| | | | | 0S Same as 0C but shaft in stainless steel | | |
| | | | | 0U Same as 0E but shaft in stainless steel | | |
| | | | | 1B Main parts of spheroidal graphite cast iron | | |
| | | | | 4B Main parts of stainless steel | | |

(1) Only size 3200

(2) Material code according to EN 12756

(3) Shortway according to ISO 1629

ATTENTION: Letter "Y" at the end of designation on sizes 6500 and 8000 is used to identify pumps without wear rings. As standard, HEGA pumps do not have wear rings.

Example for order:

For pump size HEGA 32 of 6 stages with 2 trimmed impellers, strengthened shaft support, cooled stuffing box shaft sealing,

bronze impellers, Viton o-rings and DIN/EN flanges vertical up: **HEGA 03206 2BM 511 0C V2**



SIHI Pumps Colombia

Carrera 34 A No. 4-B- 33 Bogotá D.C.
Tel. (57) 1 - 3649264

www.sihi.com.co • www.sterlingSIHI.com

