

LPE3 Std Line

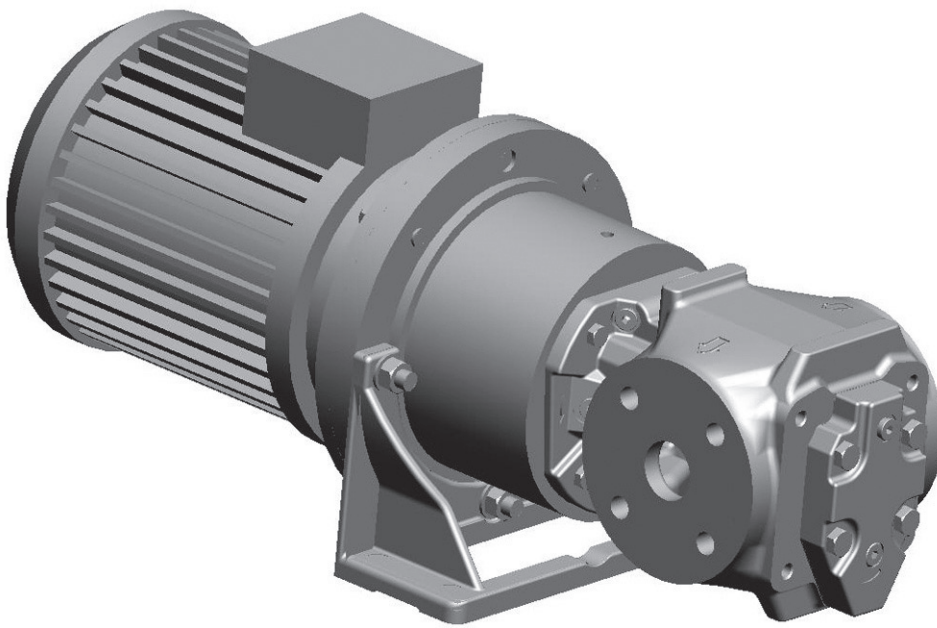

Product Description



Flow volume:	10 - 180 l/min
Max differential pressure:	16 bar
Applications:	Circulation, lubrication and transfer

1. Applications

1.1 Functionality

The Std Line (standard) LPE pump comes in two executions; Lube Line and Fuel Line. The main difference is the shaft seal design; (V-Seal) - optimized for light duty and (T-Seal) - heavy duty respectively.

The LPE pump is used for a number of different fluids:

Lubrication oil, fuel oil, vegetable oil, hydraulic oil and other hydraulic fluids, polymers, emulsions and any non-aggressive fluid with sufficient lubricating properties.

1.2 Applications

Typical applications are:

- Lubrication of diesel engines, gears, gas and steam turbines, hydro turbines and paper machines
- Circulation for cooling and filtration in large machineries, hydraulic systems and transformer oil for insulation in transformers
- As transfer pumps onboard vessels, in power plants, oil factories, refineries, tank farms etc
- Fuel supply duties for engines
- Supply and circulation of fuel oil

1.3 Use in potentially explosive areas

The pump fulfils the requirements according to EU explosion-protection directive 2014/34/EU (ATEX 100a) for devices in device class II, category 2G.

Classification into temperature classes according to DIN EN 80079-36 depends on the temperature of the pumped liquid.

Refer to the proposal or order documentation for the maximum permissible liquid temperature for the respective temperature classes.

Note: When operating the pump in category 2, suitable measures must be provided to prevent impermissible warming of the pump surfaces in the event of disturbance.

1.4 Installation

The pump is designed to be flange-mounted to its electric motor via a connecting frame and a flexible shaft coupling. By the angle bracket, the pump may be mounted horizontally or vertically. For vertical installation, a stand mounted on the rear cover can be supplied (version NxYP).

As standard, the pump is delivered excluding counter flanges (DIN type), but can be included if requested.

As standard the pump is delivered with the discharge side to the left when seen from the pump rear end (see below).

For more information about installation, see Installation and Start-up instruction for low pressure pumps.

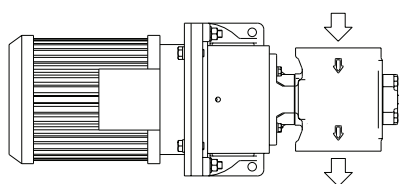

Mounting standard picture M93-0.

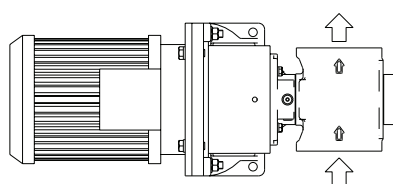

On request the pump can be delivered with opposite flow direction, M39-0.

2. Pump model code

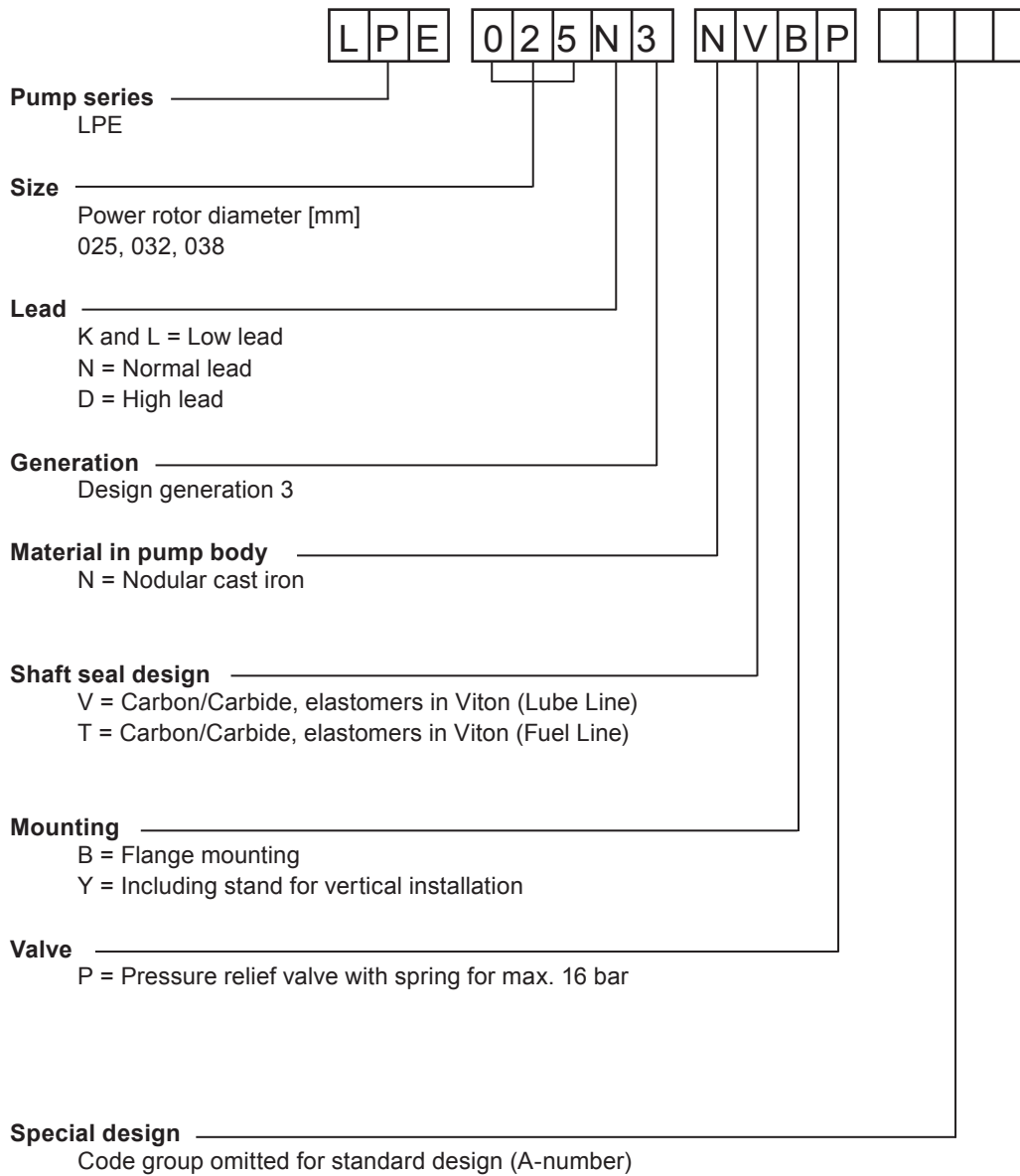

3. Technical Data

3.1 Pressure Information

Pressure relief valve

The pump is equipped with an integral pressure relief valve with internal return, limiting the differential pressure across the pump and protecting the pump. Should the discharge line be blocked, the relief valve will open by the pressure. The valve is adjustable for different opening pressures.

The value of the pressure limit can be set at the factory and should be adjusted at installation (see Installation & Start-up instruction for low-pressure pumps).

The maximum pressure accumulation varies with pump size, speed and viscosity, but will normally not exceed 4 bar.

The valve has a maximum set pressure of 16 bar.

Inlet pressure

Minimum inlet pressure (suction capability) is dependent on fluid viscosity and rotation speed. It increases with decreasing viscosity and decreasing speed. Information about minimum inlet pressure for each individual duty case can be obtained from IMO AB or pump selection software WinPump.

Maximum inlet pressure is 7 bar.

Discharge pressure

Maximum discharge pressure is 16 bar.

Differential pressure

Maximum differential pressure is 16 bar but reduced at low viscosities according to table below

Viscosity [cSt]	1,4	2	6	10	>12
Max. diff. pressure [bar]	6,9	8	12,4	15	16

Refer to your IMO representative or use the pump selection software WinPump to determine the exact operating limits.

3.2 Driver information

Driver type

The pump is designed to be connected to an electrical motor by a flexible shaft coupling.

Speed

The maximum speed is 3600 rpm. For higher speeds, contact IMO AB.

Rotation

The pump is designed to operate in one rotational direction only, as standard clockwise when facing the shaft end. Pumps for CCW rotation can be delivered on special request.

For shorter periods of time, a few minutes for emptying a discharge line, the pump may be operated in reverse direction, provided the back pressure is limited to 3 bar.

3. Technical Data

3.3 Sound level

Typical pump sound levels refer to free field conditions at a distance of 1 m from the pump. Noise of driver excluded in the quoted figures. The sound levels are measured at a discharge pressure of 5 bar, speed 2940 rpm and viscosity 40 cSt, according to ISO-3741.

Size	025	032	038
Sound level dB [A]	58	58	58

3.4 Moment of Inertia

Moment of inertia [10^{-6} kgm²]

Size	025	032	038
Value	49	72	194

3.5 Fluid viscosity

Lube Line seal (Seal version code V):
1,4 – 800 cSt for Lube and hydraulic oil

Fuel Line seal (Seal version code T):
1,4 – 3500 cSt for Fuel oil

For higher viscosity, contact IMO AB.

3.6 Fluid temperature

Lube Line (Seal version code V): -20 – +90 °C
Fuel Line (Seal version code T): -20 – +155 °C

4. Design

4.1 Ball bearing

The pump is fitted with an internal ball bearing which continuously is being greased by the handling media.

4.2 Design material

Model	Material pump	Material rotor	Material idler	Material seal	Material Elastomers
LPE NV	Nodular cast iron	Steel, surface treated	Cast iron, surface treated	Carbon/Silicon carbide	Viton
LPE NT	Nodular cast iron	Steel, surface treated	Cast iron, surface treated	Silicon carbide/ Silicon carbide	Viton

5. Performance

Typical performance values at 5 bar

Flow calculated at 26 cSt, power at 260 cSt.

Pump performance established according to EN 14343.

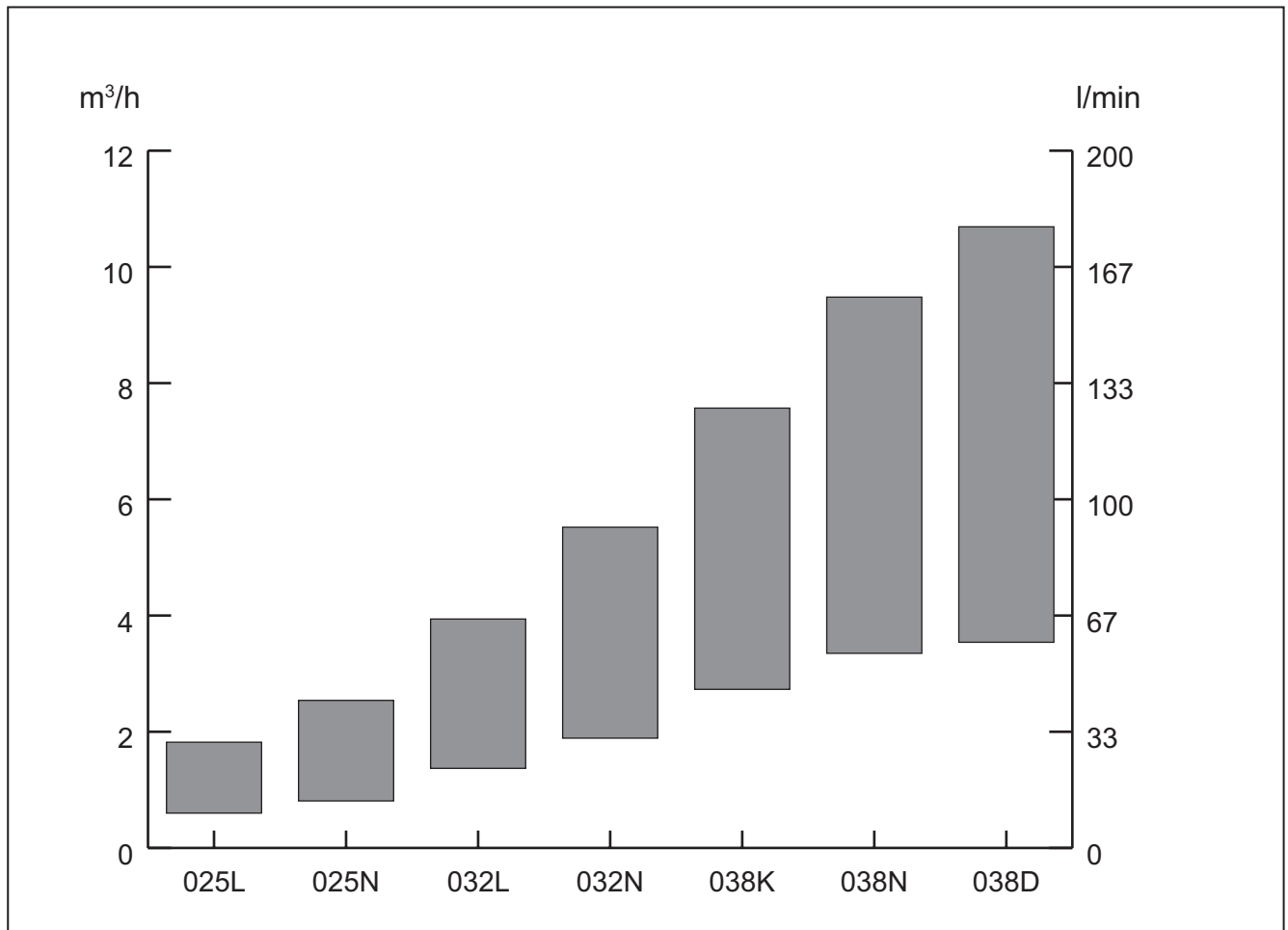

	025L		025N	
rpm	l/min	kW	l/min	kW
1470	10,0	0,3	13,5	0,4
1770	12,9	0,4	17,7	0,5
2950	24,5	0,9	34,1	1,0
3550	30,4	1,1	42,5	1,3

	032L		032N	
rpm	l/min	kW	l/min	kW
1470	22,8	0,5	35,9	0,8
1770	29,0	0,7	44,6	1,0
2950	53,3	1,3	79,0	1,9
3550	65,6	1,7	96,4	2,4

	038K		038N		038D	
rpm	l/min	kW	l/min	kW	l/min	kW
1470	45,5	1,0	55,8	1,3	59,1	1,2
1770	57,1	1,3	70,5	1,7	76,2	1,5
2950	102,9	2,5	128,4	3,2	143,9	2,9
3550	126,2	3,2	157,9	4,1	178,2	3,6

6. Sectional view

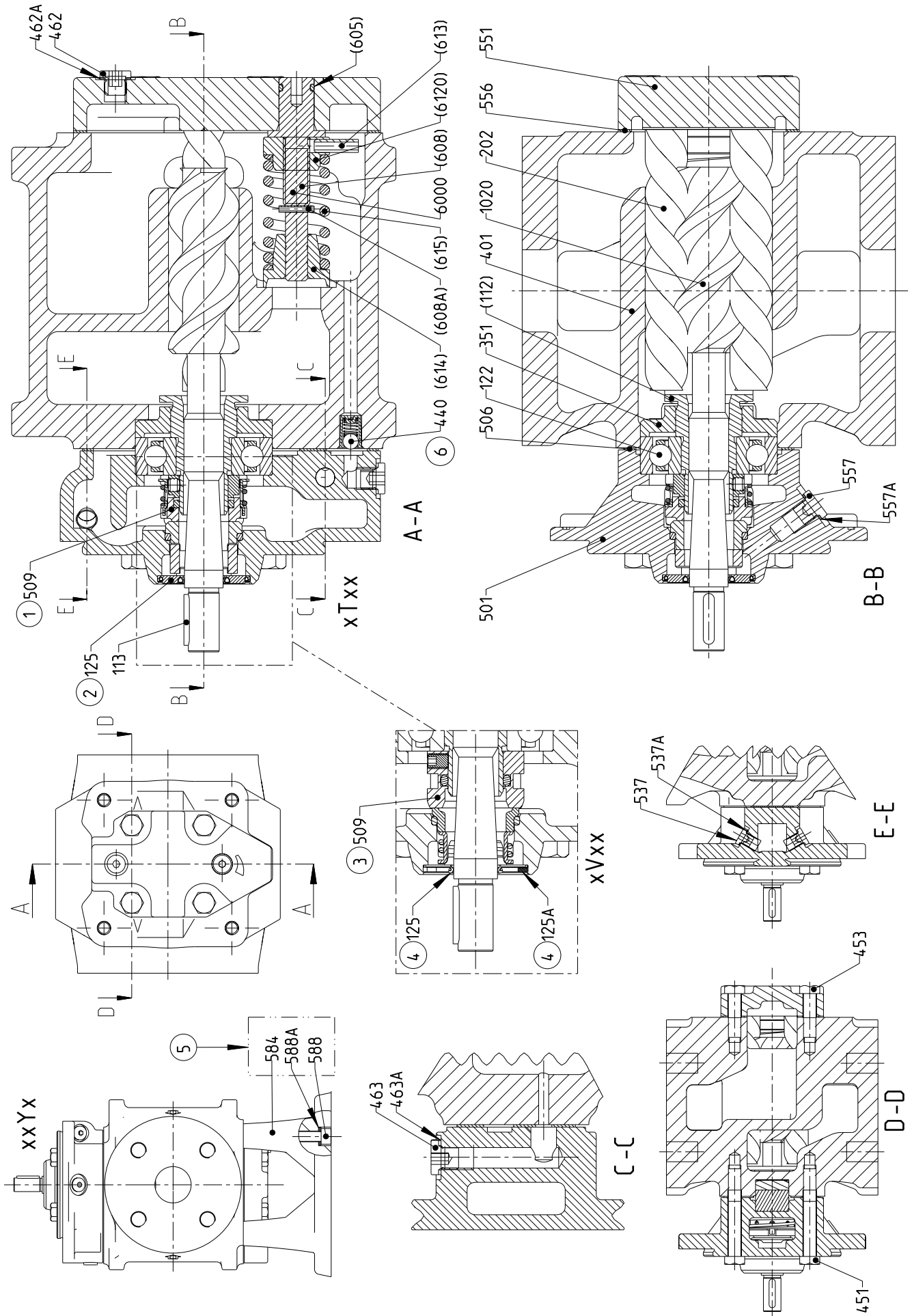

7. List of components

Pos No	Denomination	Pos No	Denomination	Pos No	Denomination
1020	Complete power rotor	462	Plug	557A	Sealing washer
(112)	Balancing piston	462A	Sealing washer	584	Vertical stand
113	Key	463	Plug	588	Screw
122	Ball bearing	463A	Sealing washer	588A	Washer
125	Secondary seal	501	Front cover	6000	Complete valve element
125A	Retaining ring	506	Gasket	(605)	O-ring
202	Idler rotor	509	Shaft seal	(608)	Valve spindle
351	Balancing bush	537	Deaeration plug	(608A)	Tension pin
401	Pump body	537A	Sealing washer	(6120)	Complete regulating nut
440	Return valve	551	Rear cover	(613)	Pin
451	Screw	556	Gasket	(614)	Valve piston
453	Screw	557	Plug	(615)	Valve spring

Drawing remarks:

- (1) Shaft seal. Execution code xTxx
- (2) Applicable for shaft seal execution code xTxx
- (3) Shaft seal. Execution code xVxx
- (4) Applicable for shaft seal execution code xVxx

- (5) Applicable for vertical mounted execution code xxYx
- (6) Removed from August 2011

Notes:

- Components with Pos No within parenthesis are parts of subassembly

8. Pump dimensions

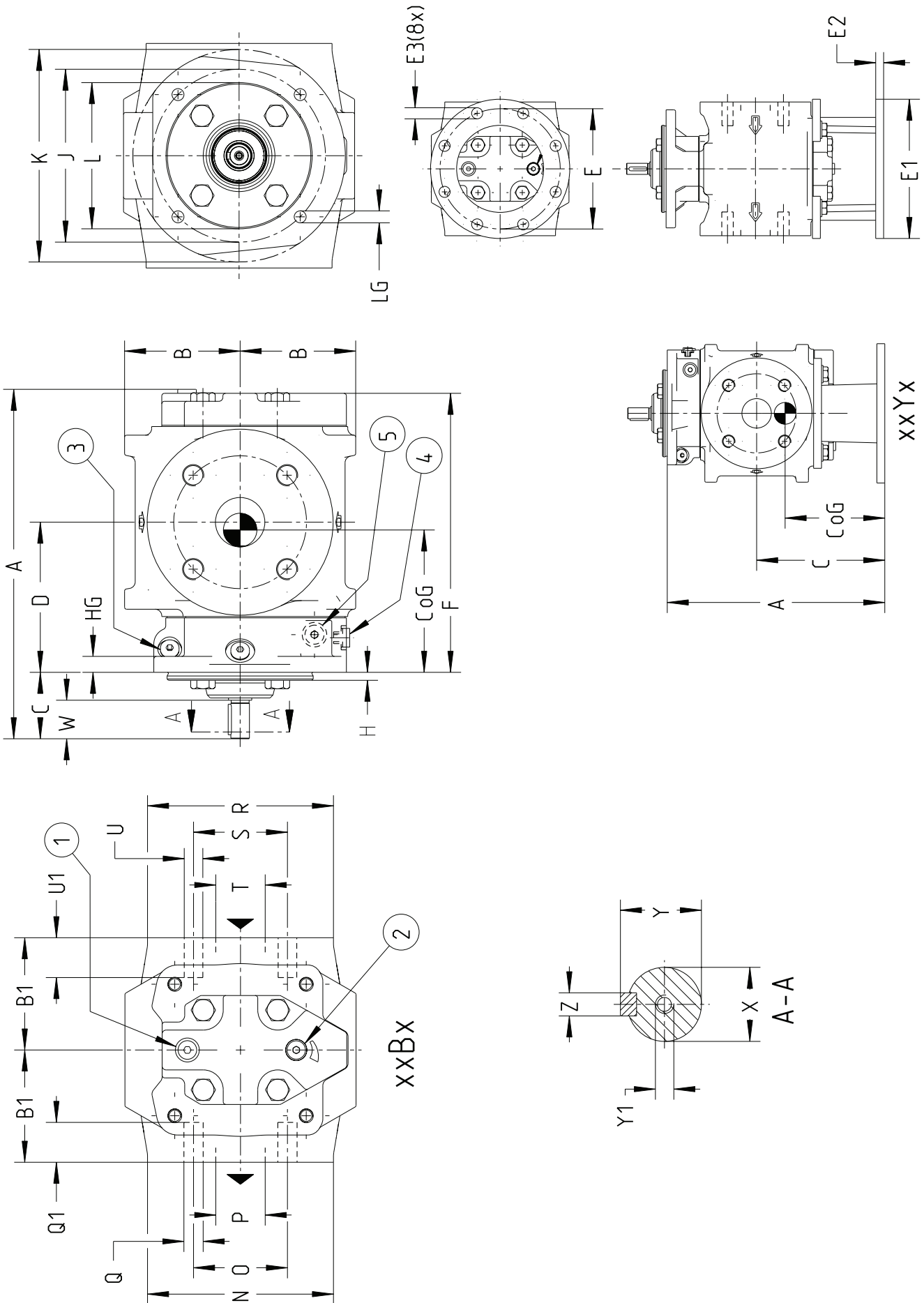

8. Pump dimensions

Pump size	Main dim.					Foot dim.			Flange dim.				Outlet				Inlet				Shaft				Weight											
	A	B	B1	C	C	D	F	E	E1	E2	E3	H	HG	J	K	L ¹⁾	LG	N	O	P	Q	Q1	R	S	T	U	U1	W	X ²⁾	Y	Y1	Z	CoG	CoG	kg	kg
025	225	240	81	75	140	100	175	138	190	17	11.5	12	130	160	110	9	115	85	25	M12	20	20	115	85	25	M12	20	29	14	16	M5	5	82	122	14	18
032	261	275	87	85	162	113	211	152	190	17	6	15	140	100	32	140	100	32	M16	25	M16	25	140	100	32	M16	25	34	19	21.5	6	103	145	20	24	
038	273	305	89	110	191	114	223	153	190	17	13.5	15	145	170	120	11	165	125	50				165	125	50		34	19	21.5	6	110	169	28	32		
Exc- cution code	xxBx	xxYx			xxBx	xxYx			xxYx																							xxBx	xxYx	xxBx	xxYx	

Drawing remarks:
 (1) Inlet gauge. ISO G1/8
 (2) Relief valve. Turn clockwise to increase opening pressure
 (3) Deaeration (2x)
 (4) Deaeration
 (5) Other side: Outlet gauge. ISO G1/8

Notes:
 - Dimensions in mm
 - Counter flanges according to DIN2633/ND16
 1) Tolerances ISO h7
 2) Tolerances ISO j6

9. Pump Unit dimensions

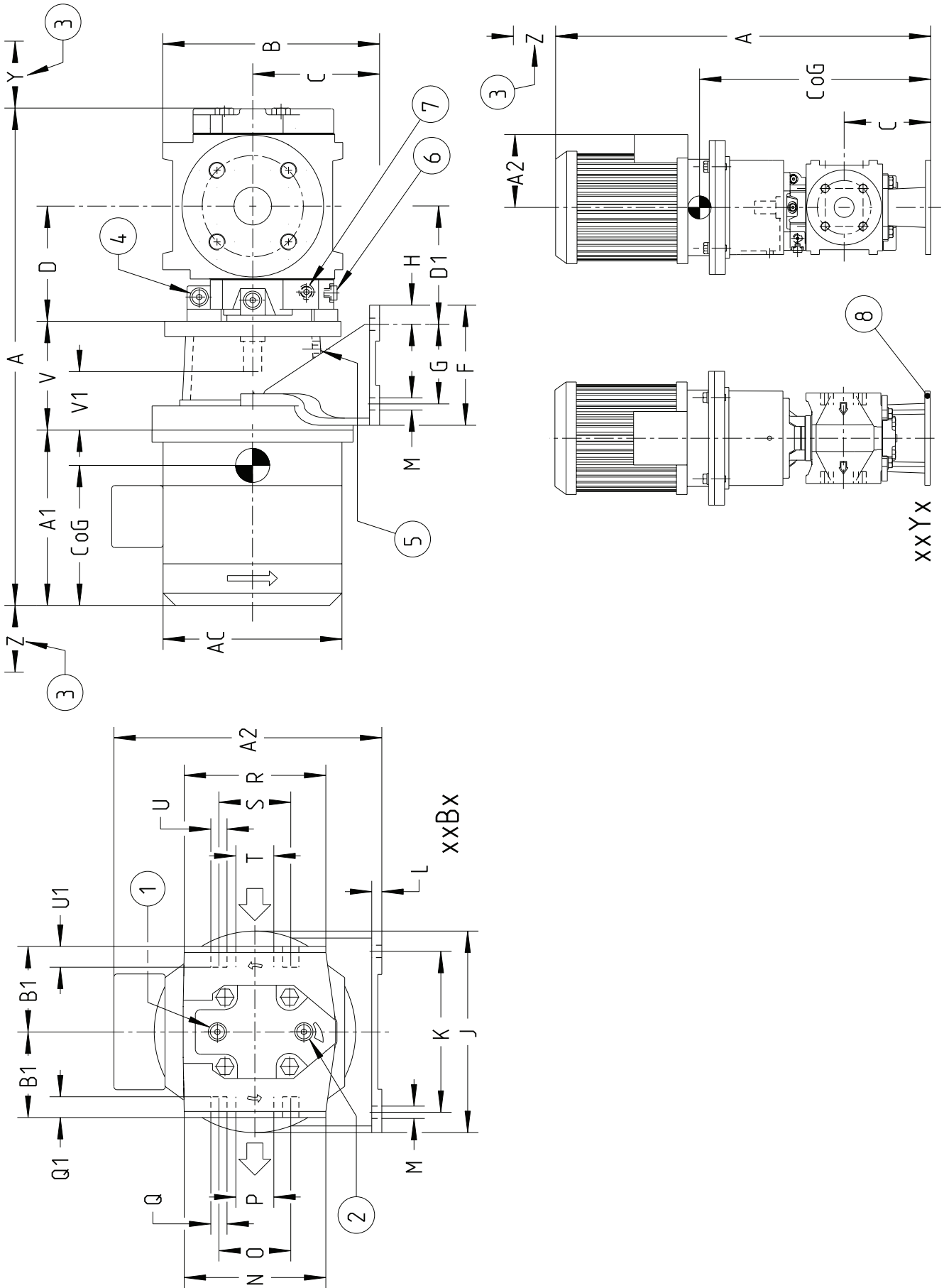

9. Pump Unit Dimensions

Pump size	IEC Frame No	Main dim.										Foot dim.										Outlet						Inlet				Dism.			Weight				
		A	A1	A2	A2	AC	B	B1	C	C	D	D1	V	V1	F	F	G	H	J	K	L	M	N	O	P	Q	Q1	R	S	T	U	U1	Y	Z	CoG	CoG	kg	kg	
025	71	483	584	210	214	114	140	181	100		128	98	48	80	50		160	140	10	Ø9															48	298	222	22	26
	80	533	598	250	249	137	156	193	112		108	108	58	90	15		210	180	12	Ø11														58	315	248	25	29	
	90	578	643	285	256	144	176	193	140	100	138	118	68	60	60		29	250	220	15	Ø14	115	85	25	M12	20	115	85	25	M12	20	68	68	319	292	30	34		
	100	611	676	308	288	156	198	213	132		128	128	78	110			29	250	220	15	Ø14													78	299	347	41	44	
	112	638	703	335	306	174	221	213	132		128	128	78	110			29	250	220	15	Ø14													78	306	370	47	50	
032	71	519	583	210	214	114	140	187	100		141	98	48	80	50		160	140	10	Ø9														48	332	226	28	32	
	80	569	633	250	249	137	156	199	112		108	108	58	90	15		210	180	12	Ø11														58	351	260	32	36	
	90	614	678	285	256	144	176	199	162	113	151	118	68	60	60		29	250	220	15	Ø14	140	100	32	M16	25	140	100	32	M16	25	68	68	357	290	37	40		
	100	647	711	308	288	156	198	219	132		141	128	78	110			29	250	220	15	Ø14													78	336	352	47	51	
	112	674	738	335	306	174	221	219	132		141	128	78	110			29	250	220	15	Ø14													78	341	376	53	57	
038	80	581	663	250	249	137	156	201	112		142	108	58	90			15	210	180	12	Ø11													58	376	263	40	43	
	90	626	708	285	256	144	176	201	112		152	118	68	60	60		29	250	220	15	Ø14													68	387	300	45	48	
	100	659	741	308	288	156	198	221	191	114	142	128	78	110			29	250	220	15	Ø14	165	125	50	M16	25	165	125	50	M16	25	78	368	351	56	58			
	112	686	768	335	306	174	221	221	132		142	128	78	110			29	250	220	15	Ø14													78	373	375	62	64	
	132	767	849	394	352	192	258	249	160		144	150	100	120	80	20	290	260	18														70	100	459	80	84		
Exe-cution code		xxBx	xxYx		xxBx	xxYx		xxBx	xxYx		xxBx						xxBx																xxBx	xxYx	xxBx	xxYx			

Notes:
 - Dimensions in mm
 - Dimensions A, A1, AC, A2 and weight are approximate values for Busck motors type MS
 - Foot VDMA 24 561 P TFL appli-cable for xxBx

Drawing remarks:
 (1) Inlet gauge. ISO G1/8
 (2) Relief valve. Turn clockwise to increase opening pressure
 (3) Space for dismantling
 (4) Deaeration (2x)
 (5) Connecting frame drainage. ISO G3/8
 (6) Deaeration
 (7) Other side: Outlet gauge. ISO G1/8
 (8) For vertical stand dimensions see Pump dimensions page 10

10. Accessories

A bare shaft pump (Fig. 1) can be ordered with the accessories in fig. 2-8.

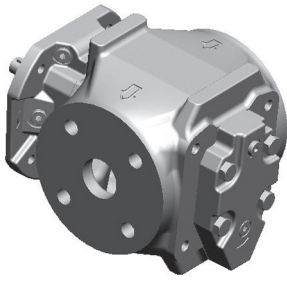

Fig. 1 Bare shaft pump



Fig. 2 Set of counter flanges

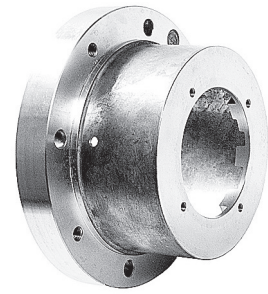

Fig. 3 Connecting frame

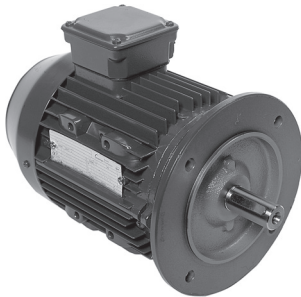

Fig. 4 Electric motor



Fig. 5 Angle bracket

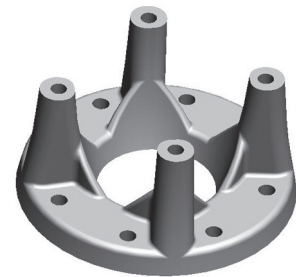

Fig. 6 Vertical stand



Fig. 7 Shaft coupling



Fig. 8 Gauge panel

11. Maintenance

Spare parts for these pumps are easily available from stock. For detailed information and know-how about service, see the Maintenance & Service Instruction for LPE3 pumps or contact IMO AB.

Adress:

IMO AB
PO Box 42090, 126 14 Stockholm
Sweden