

Vorwald
-pneumaattiset
paisunta-akselit



Pneumatic
expansion shafts



Mechanical
expansion shafts



Expansion couplings



Expansion chucks
and adapters



Friction and
knife shafts

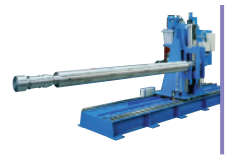

Shaft handling

Pneumatic expansion shafts

and safety chucks





Pneumatic expansion shafts



Mechanical expansion shafts



Expansion couplings



Expansion chucks and adapters



Friction and knife shafts



Shaft handling

		Page
1.1	Central bladder shaft	
1.1.1	Light model Series A	4
1.1.2	Heavy duty model Series 403	6
1.1.3	Special forms Series L	8
1.2	Flat bladder shaft	
1.2.1	Light model Series MB	10
1.2.2	Heavy duty model Series 409	12
1.3	Safety chucks	14
1.4	Customised versions	16
1.5	Inquiry data sheet	17

We want you to be successful

The expansion units presented in this catalogue originate from the Vorwald Classic Programme and the winding technology products developed and marketed by Deublin USA and Germany. By virtue of their specific features these products have acquired a large market share in the field of rewinding and unwinding systems in the paper and film processing industry ranging from the smallest to the largest installations. The sheer breadth of products within the Neuenhauser-Vorwald range means that all areas of winding technology are now covered. Each product reflects the quality and experience of the manufacturing company behind it. Neuenhauser-Vorwald manufactures these products in European factories that are equipped with ultra-modern facilities and have been **certified according to DIN ISO 9001**. Our product quality and depth of experience ensures for all our customers economic utilisation of our expansion units.



Pneumatic expansion shaft

Series A

with individual expansion ledges

Vorwald expansion shafts of the Series A are the standard models with individual expansion ledges, that can be used in nearly all applications. The simple and well designed construction ensures a long service life.

Three expansion ledge types are available for covering all requirements: Lengthwise grooved expansion ledges made of aluminium, expansion ledges made of steel or expansion ledges made of polyurethane. The number and positioning of the expansion ledges in the shaft body are determined by the customer requirements.

The lengthwise grooved surface of the steel and aluminium expansion ledges permits the greatest possible torque transmission for cardboard cores. The smooth surface of the polyurethane expansion ledges permits this force transmission for steel or plastic cores. All Vorwald expansion ledges are designed with a bevel, a "guiding angle", to permit easy push-on and push-off of the material cores. Expansion shafts with expansion ledges are available for cores with an internal diameter in the range from 12.5 to 300 mm.

A further very important advantage of the Vorwald expansion shafts is the design of the journals that are attached to the shaft body with screws. The tight dimensional tolerances of the journals provide a positive fit construction. Dismantling of a shaft designed this way is very much simpler than normally encountered with shafts where the journal is attached with set screws. The shaft journals with the same principal dimensions are exchangeable with other Vorwald shaft journals. Machining by the customer to ensure a good fit in the case of a replacement is not necessary.

The shaft bodies can be made of numerous materials with various wall thicknesses – depending on the application. Based on the Vorwald standard, the expansion shafts are customised according to the modular design principle. If the bladder starts to leak, as can happen from time to time with every expansion shaft, the unique internal constructional design makes a repair possible within a very short time. By keeping a complete inner assembly or "repair kit" in stock, a bladder defect can be remedied within minutes.



Sectional drawing with inner assembly of an expansion shaft, Series A

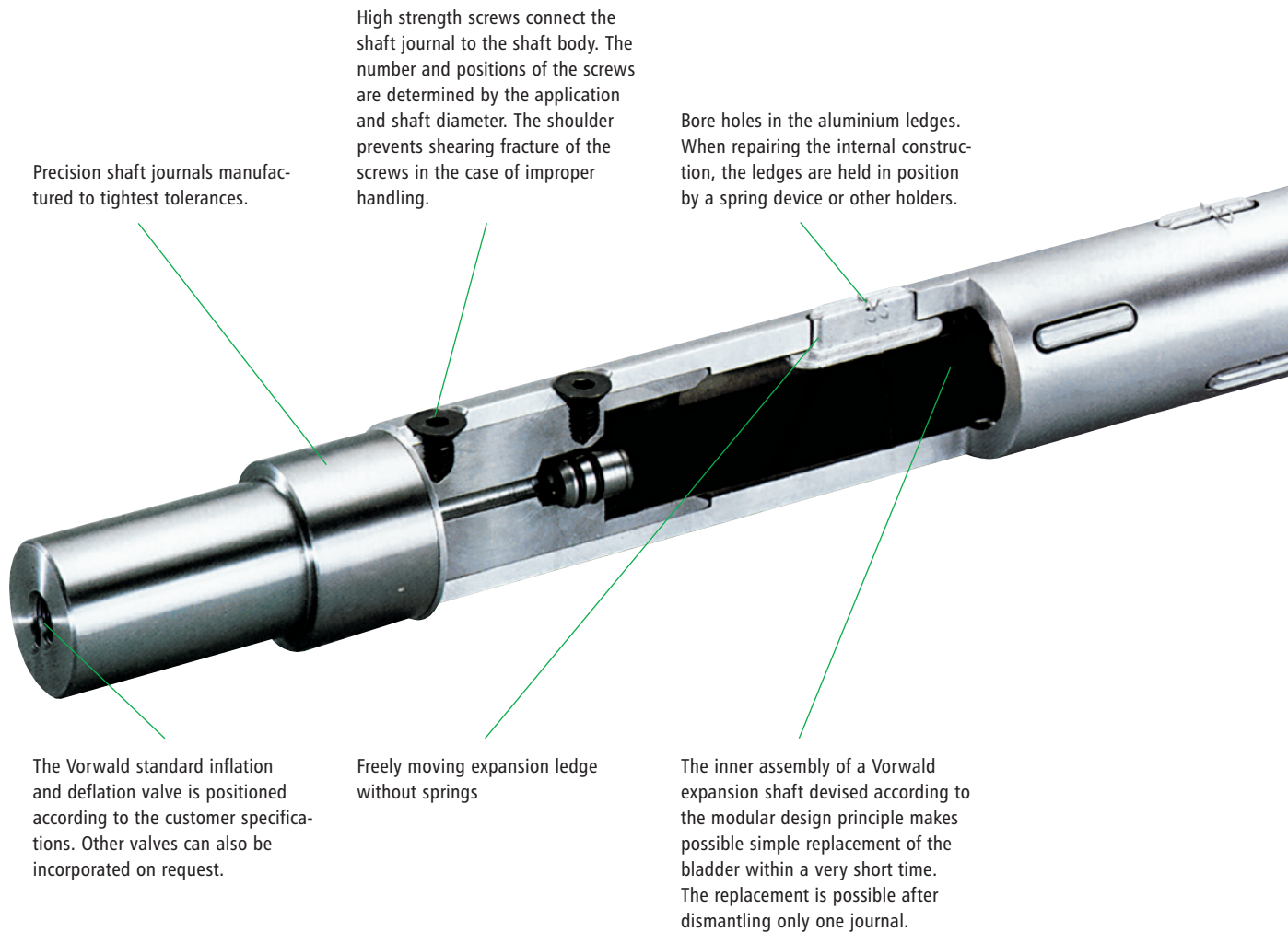

Options

- WR Extended expansion range for clamping varying core diameters
- OL Overlapping expansion ledges for narrow web winding
- CB Preliminary centering of the core over the shaft body
- CE Preliminary centering of the core with additional expansion ledges
- Special dimensions are possible on inquiry

Advantages

- + Simple construction according to the modular design principle
- + Dirt accumulation is minimised
- + High rotation speeds are possible
- + Very short repair times
- + Numerous variants

Available shaft diameters
from 12.5 to 300 mm



Pneumatic expansion shaft Series 403

with individual expansion ledges

These unusually robust Vorwald expansion shafts of the Series 403 L are intended for utilisation under conditions of heavy reel weights and large torques.

As with the Series A, these expansion shafts are equipped with individual expansion ledges. The simple construction permits direct replacement of the expansion ledges from outside. Three types of expansion ledges are available to cover all requirements: Lengthwise grooved expansion ledges made of aluminium, expansion ledges made of steel or rubber expansion ledges. The number and positioning of the expansion ledges in the shaft body are determined by the customer requirements.

The lengthwise grooved surface of the steel and aluminium expansion ledges permits the greatest possible torque transmission with cardboard cores. The smooth surface of the rubber expansion ledges permits this force transmission for steel or plastic cores.

All expansion ledges are retracted into the carrier body by an internal plate spring, so that the shaft can easily be pulled out of the core. Expansion shafts with expansion ledges are available for cores with an internal diameter in the range from 50 to 300 mm.

Further very important advantages of these Vorwald expansion shafts include the light weight of the shaft compared with its high load carrying capability, by using high strength materials (steel, aluminium, CFK) as well as the easy to maintain construction. If the bladder starts to leak, as can happen from time to time with every expansion shaft, the unique internal constructional design makes a repair possible within a very short time. By keeping a complete inner assembly or a "repair kit" in stock, a bladder defect can be remedied within minutes.



Sectional drawing with inner assembly of an expansion shaft, Series 403

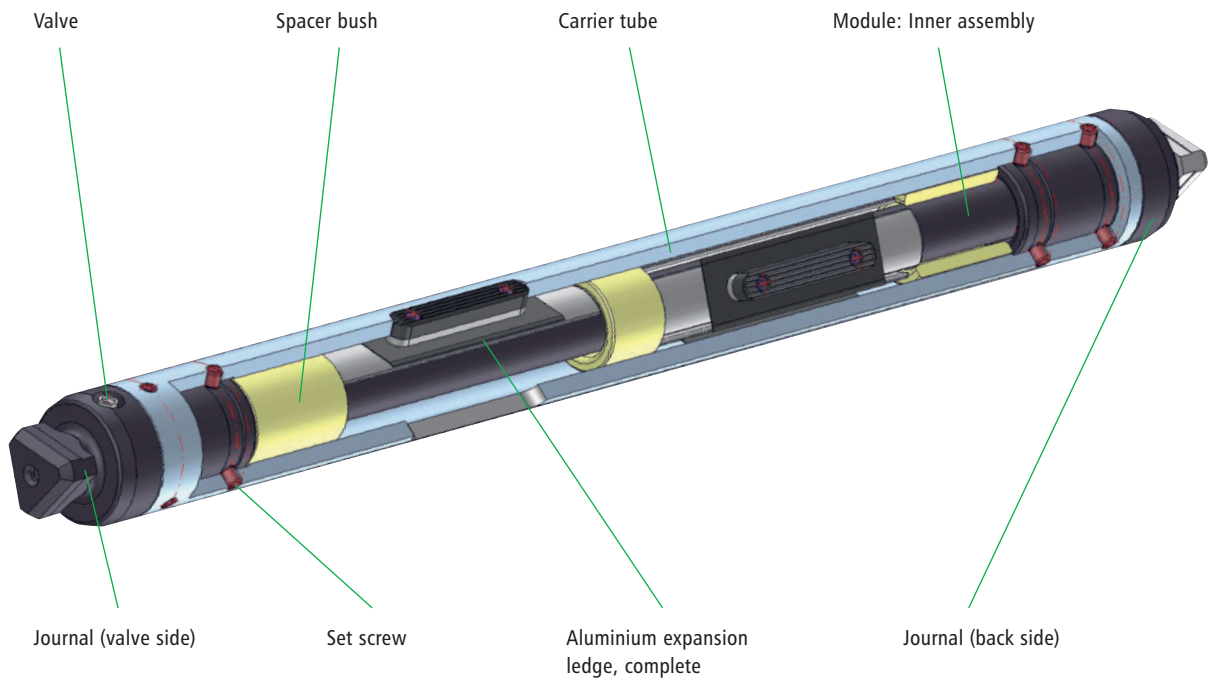

Advantages

- + Simple construction according to the modular design principle
- + Numerous variants
- + Heavy reel weights and large torques possible
- + Expansion ledge retracted by spring system
- + Short repair times, by virtue of externally accessible expansion ledges
- + Robust design

Available shaft diameters
from 50 to 300 mm

Special dimensions are possible on inquiry.

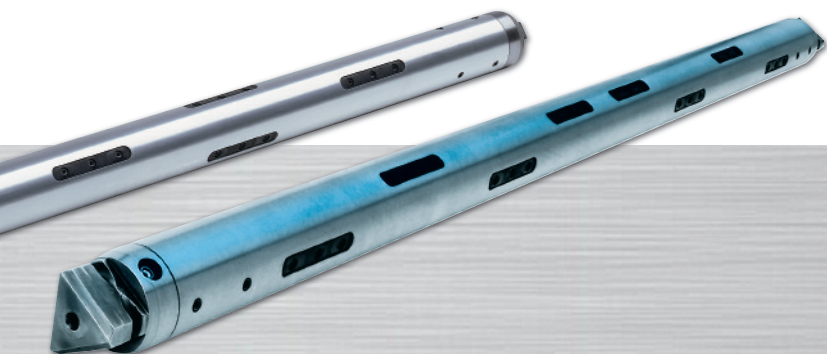

Pneumatic expansion shaft Series L

with continuous expansion leaves

The Vorwald expansion shafts of the Series L were developed for applications where flexibility is required as well as for use with thin walled cores when deformations could lead to problems.

The obvious advantage of the expansion leaves is the continuous clamping over the entire length of the inside surface of the core. The outer surface of the leaves is available in smooth or lengthwise grooved versions, or as combination. The outer and inner leaves are connected with DIN screws, enabling easy quick replacement.

In particular the version LG with a fixed expansion leaf permits improved true running and clamping of the winding material when winding without a core.

For the standard leaf version the leaf length is chosen to ensure easy servicing, because the journal screw fitting is freely accessible as for the Series A.

The tight tolerances of the shaft/journal connection in combination with the fixing screws ensures trouble-free operation.

The modular shaft construction permits, replacement of the shaft journals without any machining by the customer, provided that the outer shaft diameter is identical.

In serial production the shaft body is made of steel, but other materials are possible depending on the required load ratings.

In standard production the leaves are made of aluminium. However, smooth or knurled steel leaves are available on request.

Replacement of the inner assembly is possible within a very short time, by releasing and removing one journal end.

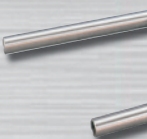

Sectional drawing with inner assembly of an expansion shaft, Series L

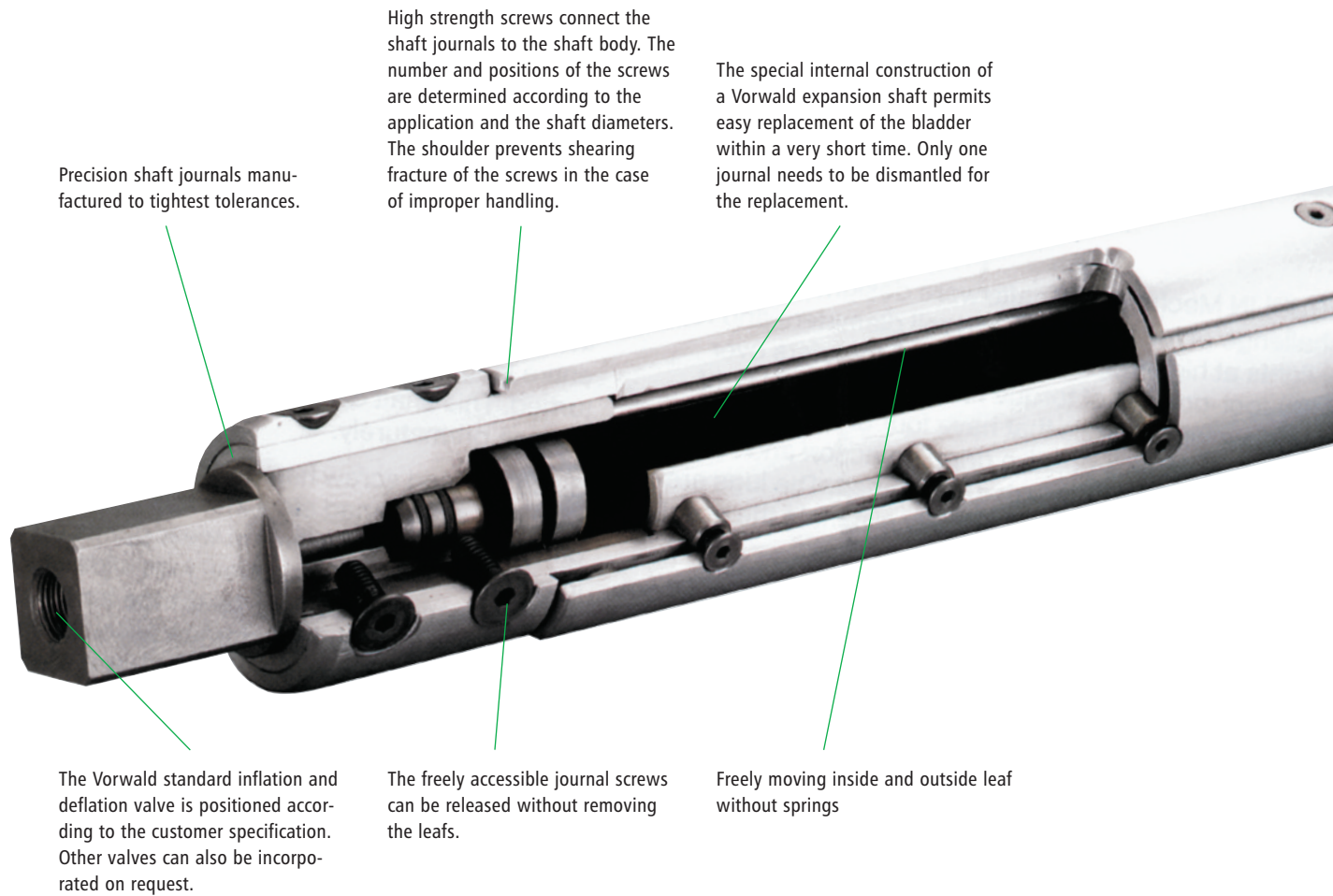

Options

- Version with smooth or lengthwise grooved expansion leaves
- WR Extended expansion range
- LG With web start clamping
- Special dimensions are possible on inquiry

Advantages

- + Suitable for winding without core and for thin walled cores
- + Simple construction according to the modular design principle
- + Very short repair times

Available shaft diameters
from 40 to 300 mm

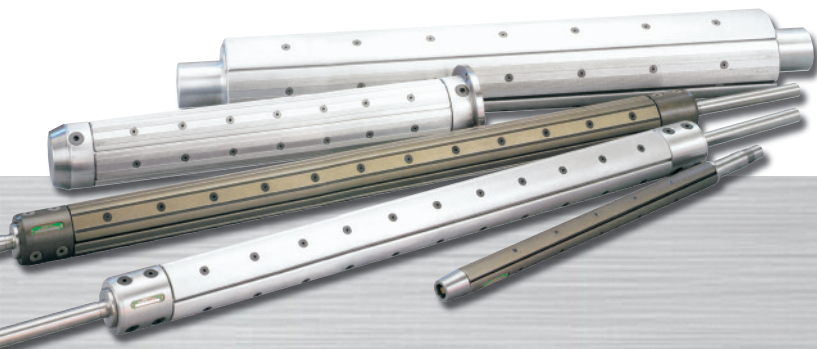

Pneumatic expansion shaft Series MB

with continuous expansion ledges

Vorwald expansion shafts of the Series MB can be used for wide as well as for the narrowest reels, by virtue of the continuous expansion ledges. This is an economical shaft which can be used for many applications. Its multiple flat bladders are readily accessible from the outside. The standard sizes are 3 inches/75 mm and 6 inches/150 mm. Other sizes are available on inquiry.

The carrier body consists of a high strength to weight ratio aluminium extrusion profile. The shaft journals are made of steel and are attached with a screw connection so that they can easily be replaced when necessary.

The MB shaft is very light and permits easy handling which can otherwise only be achieved by using the considerably more expensive CFK-shafts.

A clamping and/or a centering function can be assigned to the expansion ledges depending on the actual requirements. The type and number of ledges is selected according to the application and customer requirements. Thus this type of shaft is very flexibly and can also be adapted subsequently to changed conditions such as new core tolerances, higher speeds, etc.

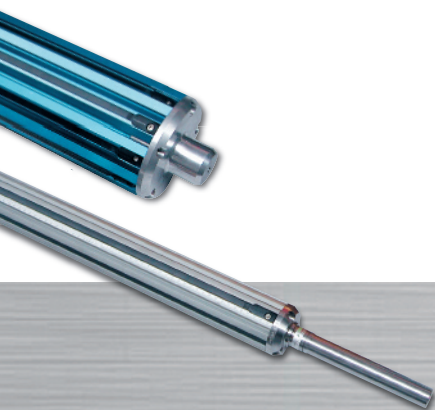

Sectional drawing of a 6 inch expansion shaft, Series MB

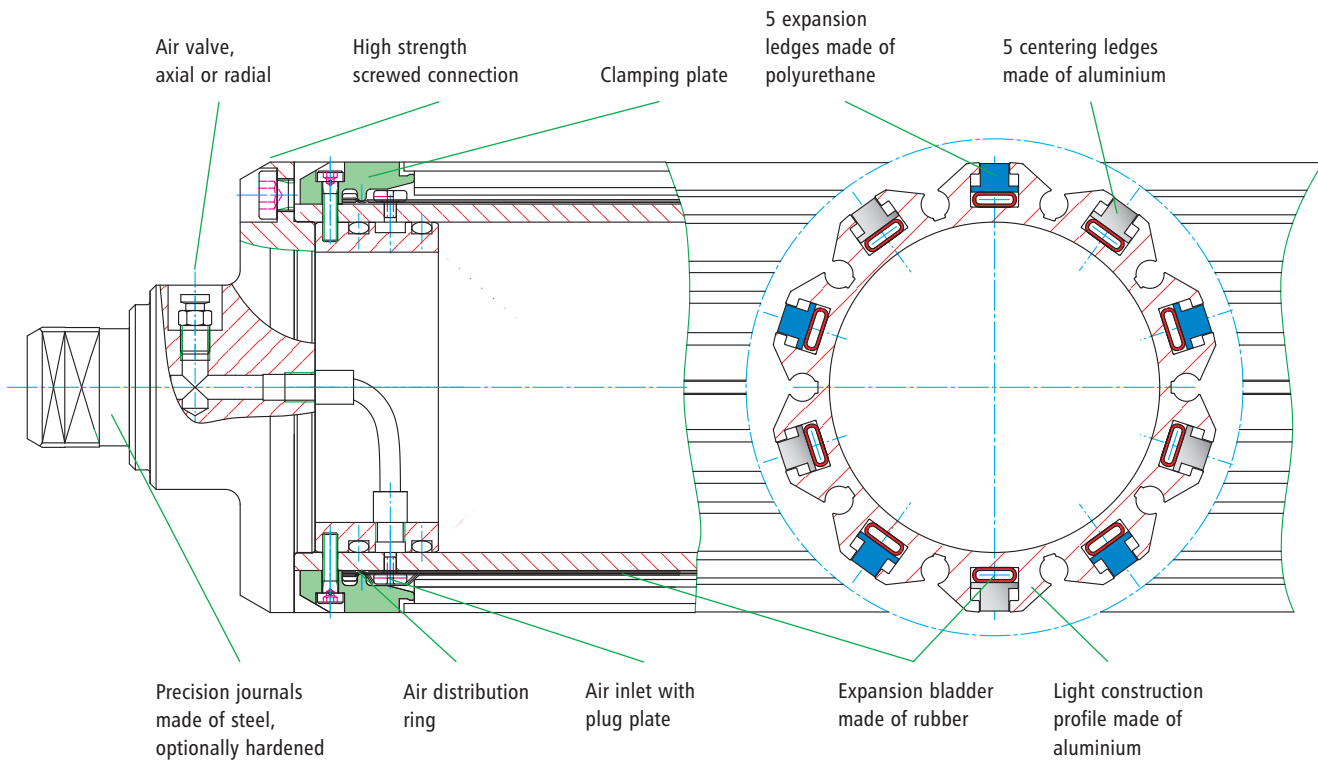

Options

- Filling valves on both sides
- Expansion ledges made of polyurethane, aluminium or plastic
- Aluminium carrier body with wear proof coating
- Quasi-centering design, matched to your core internal diameter
- Special dimensions are possible on inquiry

Advantages

- + Simple construction according to the modular design principle
- + Parts subject to wear are readily accessible from outside
- + High rotation speeds possible
- + Low weight of the shaft
- + Secure clamping of the narrowest webs

Available shaft diameters
from 12.5 to 300 mm



Pneumatic expansion shaft

Series 409

with continuous expansion ledges

Vorwald expansion shafts of the Series 409 are suitable for wide as well as for the narrowest reels by virtue of the continuous expansion ledges. The expansion shaft transmits very large torques and has an exceptionally high reel weight carrying capability.

This is an economic and flexible shaft which has a clamping system that is readily accessible externally. It is manufactured in standard sizes of 3 inches/75mm and 6 inches/150mm. Other sizes are available on inquiry.

The carrier body consists either of a high strength aluminium extrusion profile, or of steel for very high load carrying applications. The shaft journals are also made of steel, and they are attached with screws so that they can easily be replaced when necessary.

The weight of the expansion shaft is light compared with the load carrying capability and permits easy handling which otherwise can only be achieved by using considerably more expensive CFK-shafts.

A clamping and/or centering function can be assigned to the expansion ledges depending on the actual requirements. The type and number of ledges is selected according to the application and customer requirements. Thus this type of shaft is very flexibly and can also be adapted subsequently to changed conditions such as new core tolerances, higher speeds, etc.

All expansion shafts described above are available on customer request in special versions and as expansion shafts with bearing on only one side.



Sectional drawing of an expansion shaft, Series 409

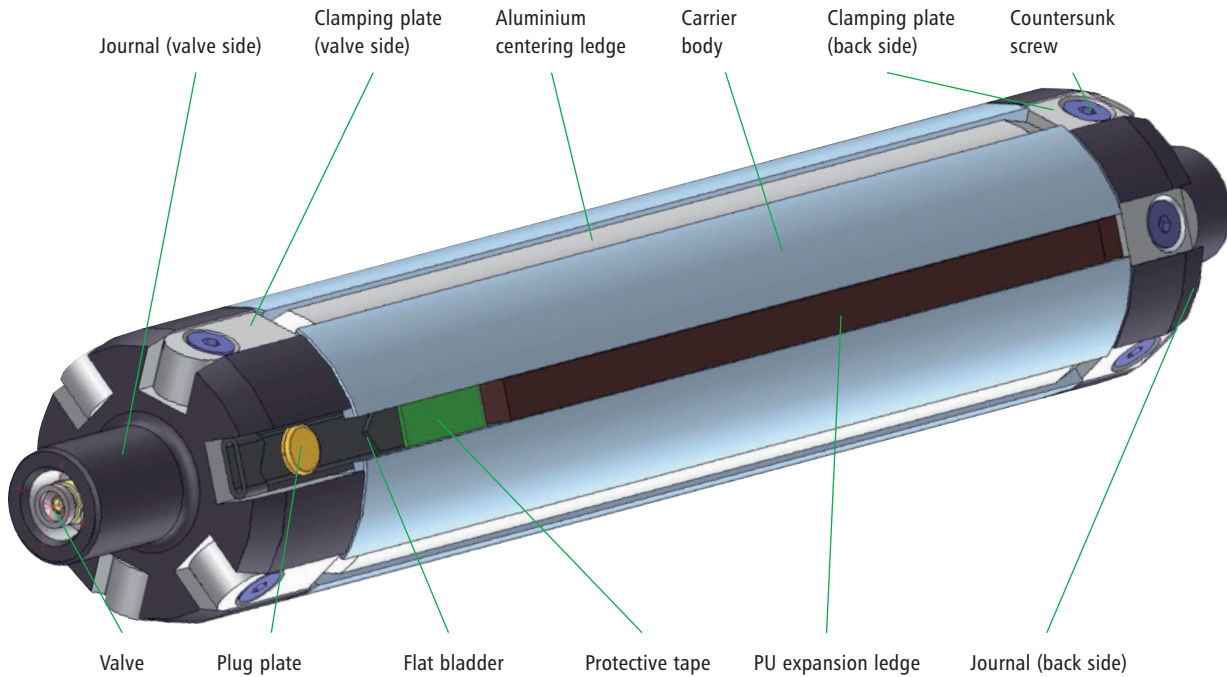

Options

- Filling valves on both sides
- Expansion ledges made of polyurethane, aluminium or plastic
- Aluminium carrier body with wear proof coating; carrier body also available in steel for high loads carrying capability
- Quasi-centering design, matched to your core internal diameter
- Special dimensions are possible on inquiry

Advantages

- + Simple construction according to the modular design principle
- + Parts subject to wear are readily accessible from outside
- + High rotation speeds possible
- + Low weight of the shaft
- + Secure clamping of the narrowest webs

Available shaft diameters
from 40 to 500 mm

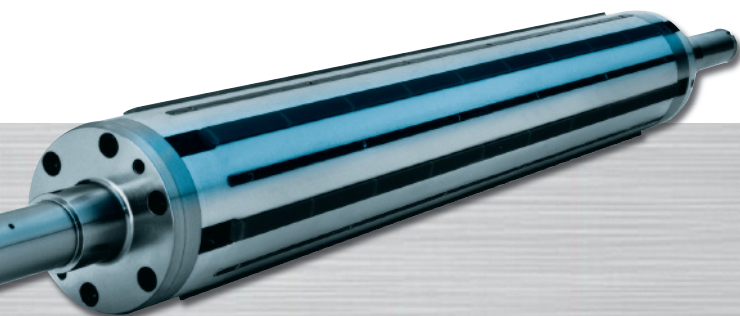

Safety chucks

Flange and foot mounted versions

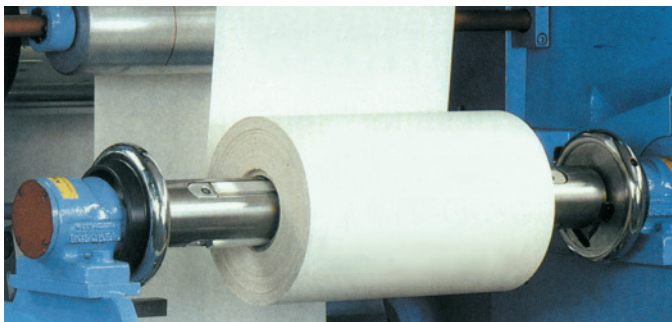

These safety chucks provide security during rewinding and unwinding operations. The locking device can only be opened, in order to take out the shaft when it is stationary at the top. Insertion is very easy via the oblique standing handwheel. For simple applications these safety chucks constitute an extremely economical solution as bearings for expansion shafts. For more exacting requirements and higher rotation speeds the safety chucks can be delivered with replaceable VT-inserts. We are pleased to offer the optimum safety chucks/ expansion shaft combination for your particular application

Features and advantages

- Safety chucks, self-closing when rotation starts
- Grooved ball bearings for robust supporting
- Foot mounted or flange mounted, with or without shaft end
- Numerous forms of journal take-up available
- Closing mechanism (handwheel) rotates
- Attractive price/performance ratio
- Optionally with replaceable VT-insert
- Optionally with special fittings such as brake, transverse and longitudinal adjustment facility
- No interfacing problems, by purchasing safety chucks and expansion shafts from the same supplier

Standard safety chucks

Foot mounted without shaft end

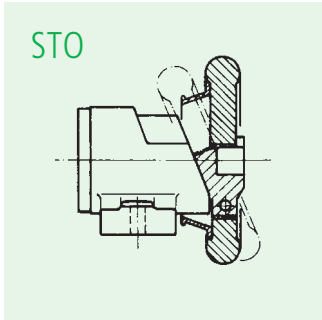

Foot mounted with shaft end

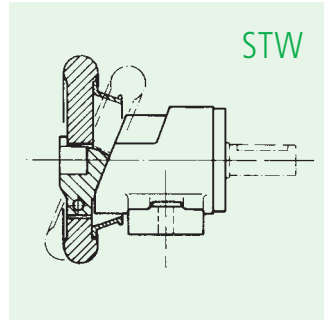

Flange mounted without shaft end

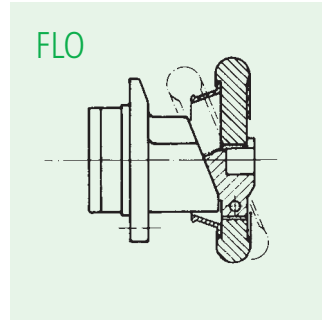

Flange mounted with shaft end

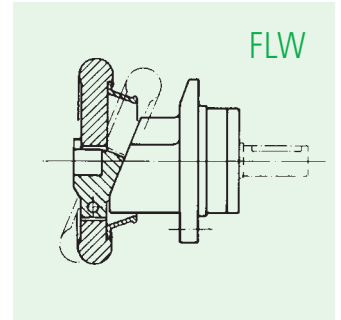

Type	Square size (mm)	Reel weight (kg)	Torque (Nm) max.
14 – 20	14 – 20	150	40
19 – 25	19 – 25	400	120
22 – 30	22 – 30	800	180
30 – 40	30 – 40	1.600	350
40 – 50	40 – 50	2.800	1.100
50 – 80	50 – 80	7.000	2.350
80 – 120	80 – 120	12.000	10.000
120 – 180	120 – 180	22.000	20.000
170 – 200	170 – 200	32.000	25.000
170 – 230	170 – 230	64.000	41.000

Options

Single disk brake

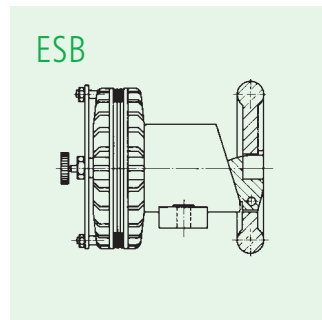

Double disk brake

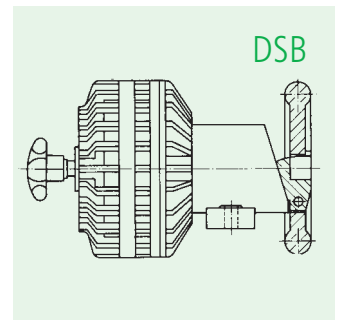

VT-inserts

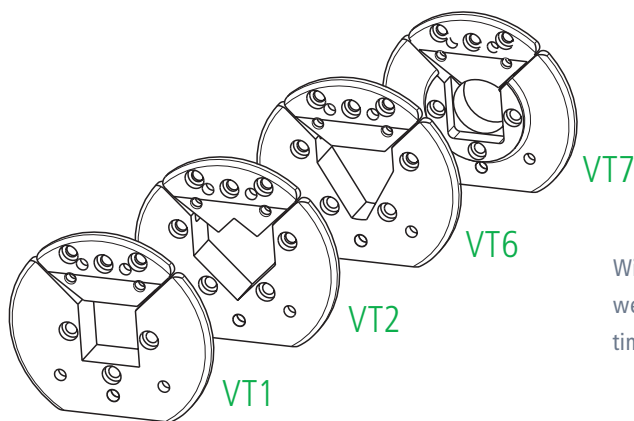

With the development of exchangeable VT-inserts we have successfully minimised the plant stoppage times.



Squared shafts

Specially developed expansion shafts for clamping square cores with expansion ledges. So far as possible standard parts are utilised for replaceability.



Carrier shafts

Vorwald manufactures customised round or square profile carrier shafts for taking up pneumatic expanding couplings.



Customised surfaces

All normal surface refinement processes can be carried out, such as hard chrome plating, chromating, nickel plating, anodising, hard coating, etc.



Customised shaft ends

All customised shaft journals can be manufactured by Vorwald, as well as complete shafts with pressed-on bearing units, etc.



Winding shafts with rotary union

The optimal combination for ensuring high functional dependability by constant axial air supply.



Cantilevered shafts with flange bearing unit FL

Cantilevered expansion shafts make a high degree of automation possible, in particular when the air inflation and deflation is implemented with a rotary union and 3/2-way valve. Also available with brake and web tension regulation.

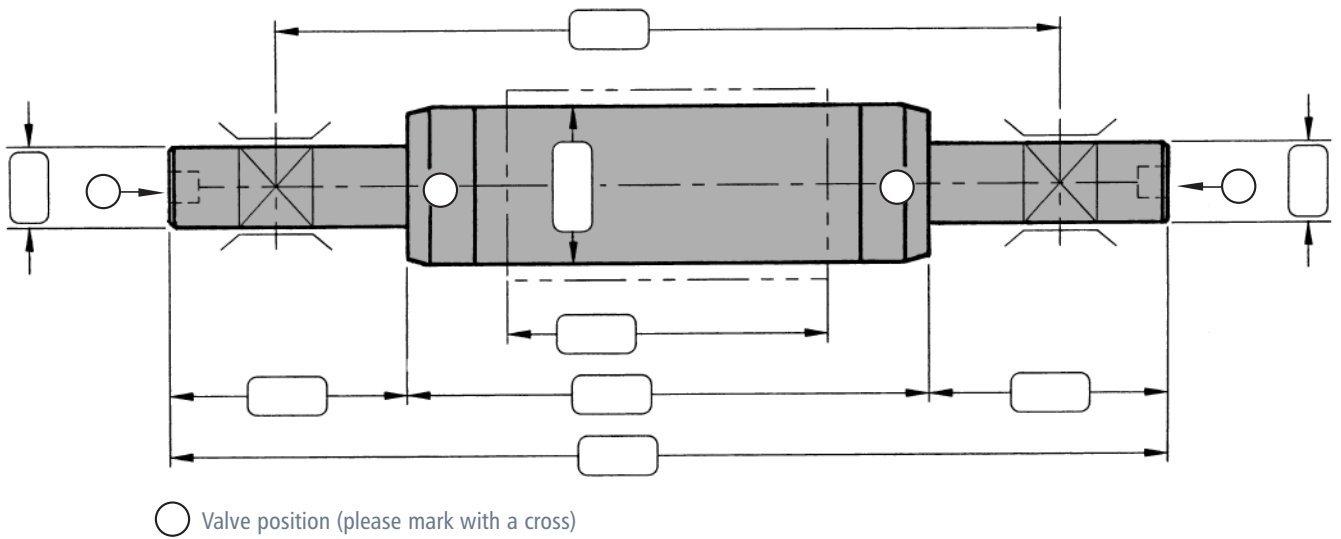

Core information

Core internal diameter _____ ± _____
 Core external diameter _____
 Core material _____

Winding method

- Single shaft winder
 - Double shaft winder
 - Winder with horizontal shaft and backing roller
 - Carrier roll winder
 - Double carrier roll winder
- Unwind unit Centre drive unit
 Rewind unit Circumferential drive unit

Technical requirements

Material _____
 Web speed (max.) _____ m/min
 Web tension (max.) _____ N;(N/cm)
 Working width (max.) _____ mm
 Working width (min.) _____ mm
 Slit width (max.) _____ mm
 Slit width (min.) _____ mm
 Reel diameter _____ mm
 Reel weight (max.) _____ kg
 Reel weight (min.) _____ kg
 Concentric expansion yes no
 Journal hardened yes no

Comments

Representations in

Austria
Czech Republic
Denmark
Finland
France

Germany
Great Britain
Greece
Hungary
Iran

Israel
Macedonia
Netherlands
Norway
Poland

Portugal
Slovakian Republic
Slovenia/Croatia
South Africa
Spain

Sweden
Switzerland
Turkey
USA



Production plant in Neuenhaus

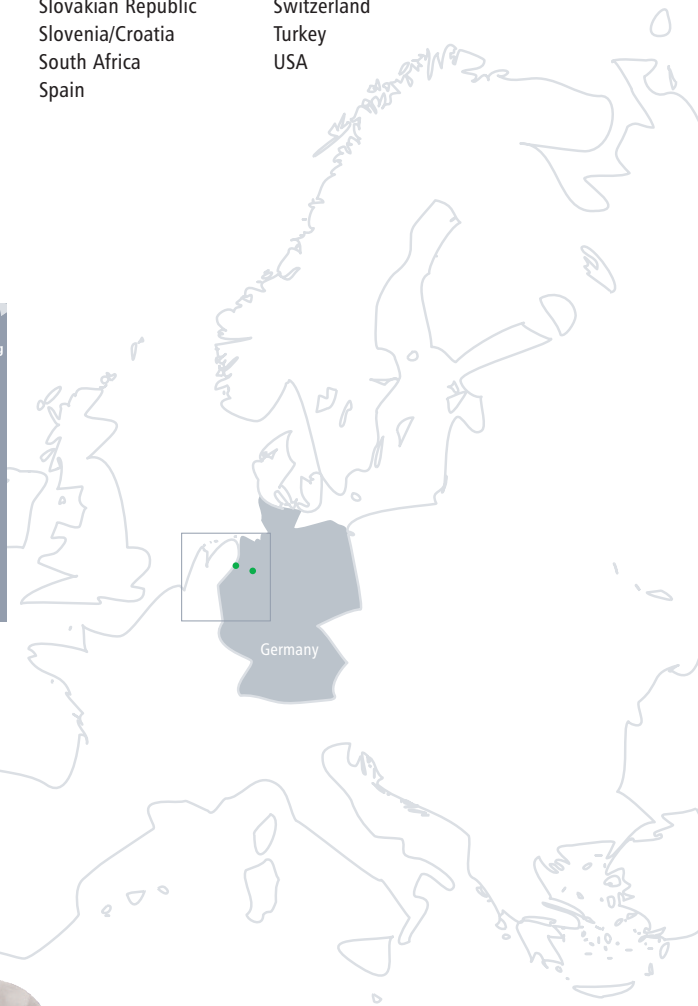

Neuenhauser Maschinenbau GmbH

Sales Department

Vorwald Expansion Units

Iburger Straße 225

D-49082 Osnabrück

Phone +49 (0) 541 / 5 05 46 - 0

Telefax +49 (0) 541 / 5 05 46 - 10

E-Mail neuenhauser@vorwald.de

Internet www.vorwald.de

Headquarters and service

Hans-Voshaar-Straße 5

D-49828 Neuenhaus

Phone +49 (0) 59 41 / 604-0

Telefax +49 (0) 59 41 / 604-206



Myynti

Vantaa Pyymosantie 4 01720 Vantaa	Turku Polttolaitoksenkatu 5 20380 Turku	Tampere Lentokentänkatu 9 C 33900 Tampere	Oulu Revontie 2 90830 Haukipudas
-----------------------------------------	-----------------------------------------------	-------------------------------------------------	----------------------------------------

Huolto ja kokoonpano

Vantaa Pyymosantie 4 01720 Vantaa	Turku Polttolaitoksenkatu 5 20380 Turku	Puh. 010 8345 500 power.hydraulics@masino.fi www.masino.fi/masino-konaflex
-----------------------------------------	-----------------------------------------------	----------------------------------------------------------------------------------

Masino Group on yritysryhmä, joka tarjoaa voimansiirtoratkaisuja, hydraulikkaa ja suodatus-tekniikkaa, pumppuja, puhaltimia ja teollisuushuoltoa, putkistotuotteita, kiinnitystekniikkaa, hitsaustekniikkaa, juotostekniikkaa, kallionlujitustuotteita, betonikuituja sekä talotekniikan kiinnitys- ja asennustarvikkeita. Liikevaihtomme on noin 65 M€ ja henkilöstön määrä 160. Toimipisteemme sijaitsevat Vantaalla (2), Ylöjärvellä, Tampereella ja Turussa.