

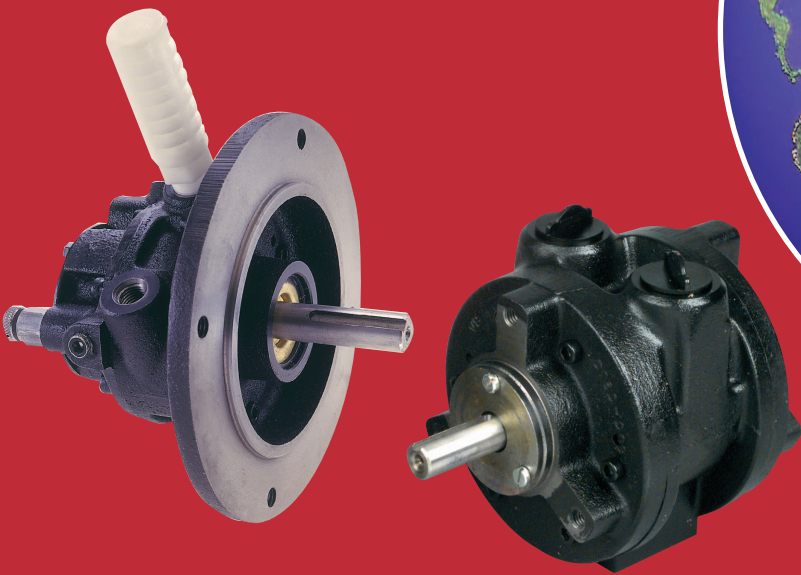

# GLOBE

## PNEUMATIC VANE MOTORS



### Your Global Force In Air Power



# GLOBE AIR POWER

## Vane Air Motors

**ATEX**

**Ex II-2-GDc-T5**

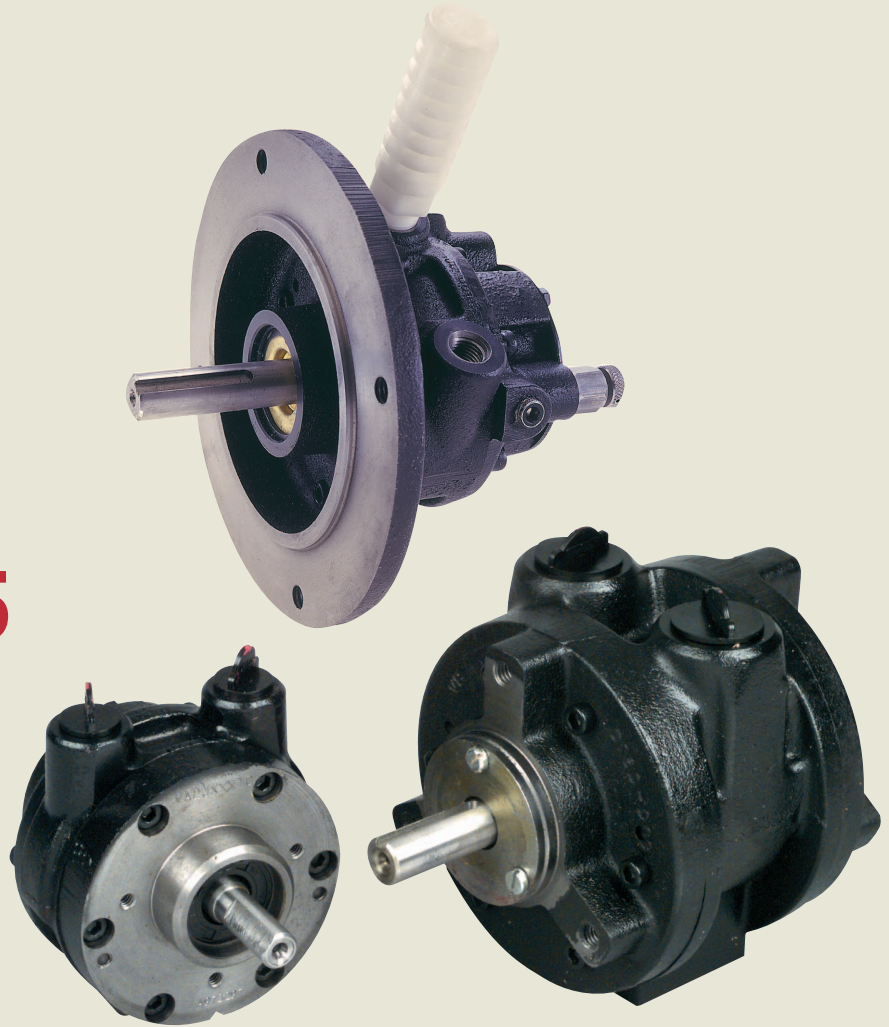

### CONTENTS

	PAGE
TYPICAL CONSTRUCTION/DESIGN	2
MOTOR SELECTION	4
V1 0.6 HP REVERSIBLE	5
V2 1.1 HP REVERSIBLE	6
V4 2.8 HP REVERSIBLE	8
V6 4.6 HP REVERSIBLE	10
V8 7.2 HP REVERSIBLE	12
V10 12.8 HP REVERSIBLE	14

### ADVANTAGES

Vane air motors offer a unique form of drive and incorporate advantages not found in other prime movers. These include:

- Inexpensive variable speed control when compared with electric motors
- Intrinsically safe in hazardous environments (e.g. mines, petro-chemical etc.)
- Can be stalled indefinitely under load without harm
- Instantly reversible
- Resistant to dirty, damp conditions
- Rugged design
- Suitable for use with natural gas
- Variety of mountings which include:
  - Foot
  - Face
  - Nema 'C'
  - I.S.O. 'D' flanges

## DESIGN FEATURES

### (Reversible)

No pins or springs.

The "Globe" blade ejection system consists of an ejection ring which maintains positive blade contact with the motor body.

Vane motors are most suitable for light duties and higher speed operations and can be supplied direct coupled to gearboxes.

A variety of operating conditions can be achieved by utilization of pressure regulators and flow control valves.

*Oil-less Motors - certain models suitable for oil-less operations  
Other gases can also be used.*

Please consult our Applications Engineering department.

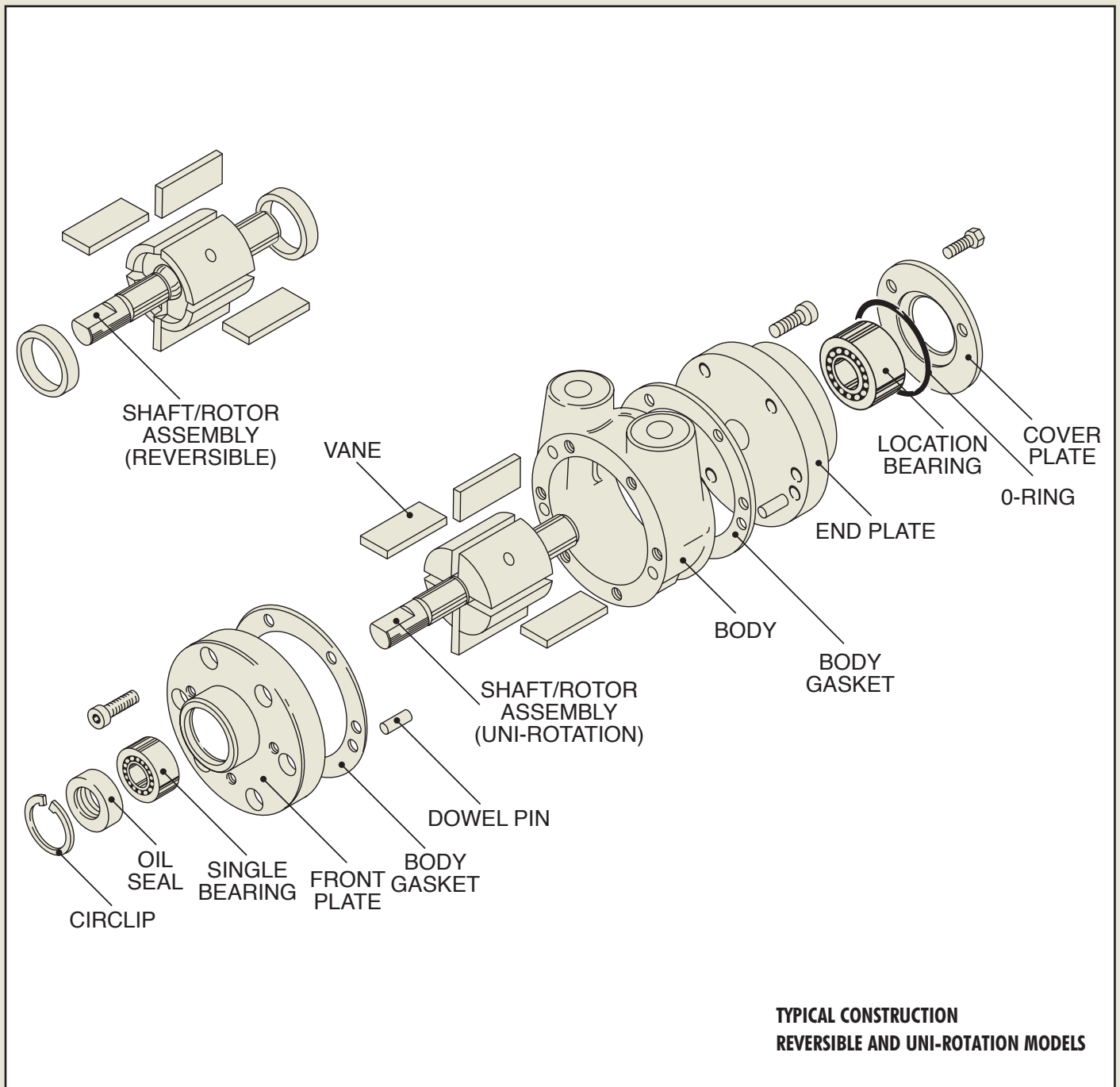



# TYPICAL SELECTION (EXAMPLE BASED ON V2)

**GRAPH 1 TORQUE - SPEED**

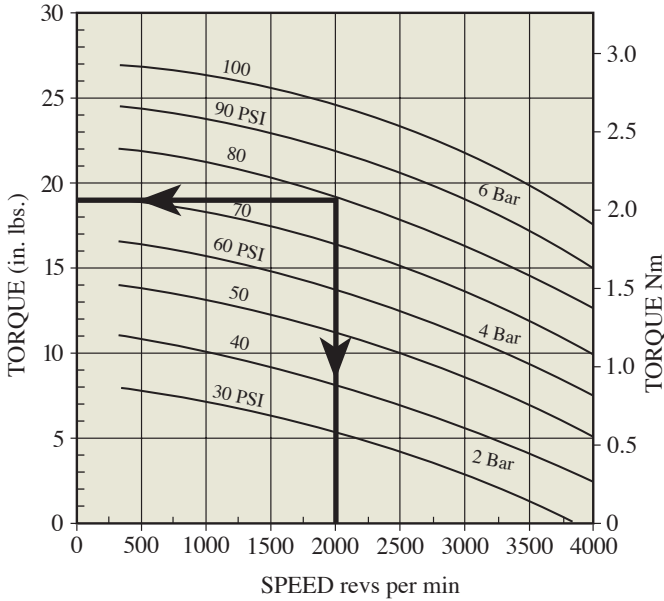

**GRAPH 2 STARTING TORQUE - PRESSURE**

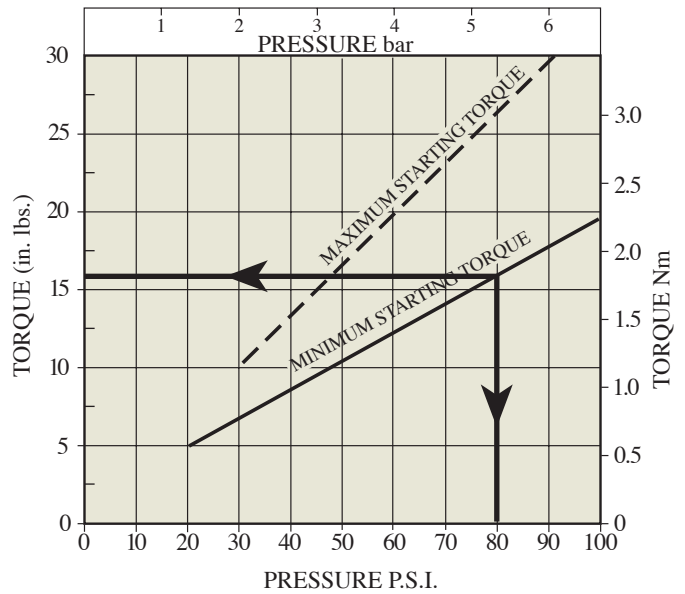

**GRAPH 3 POWER - SPEED**

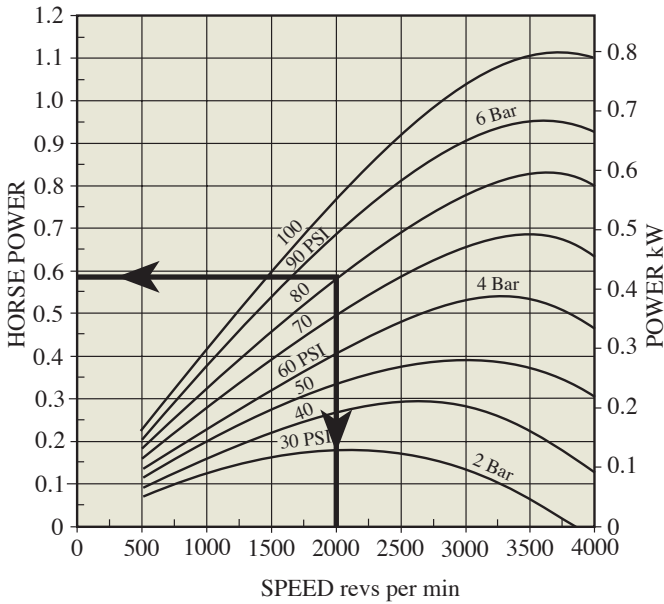

**GRAPH 4 CONSUMPTION - SPEED**

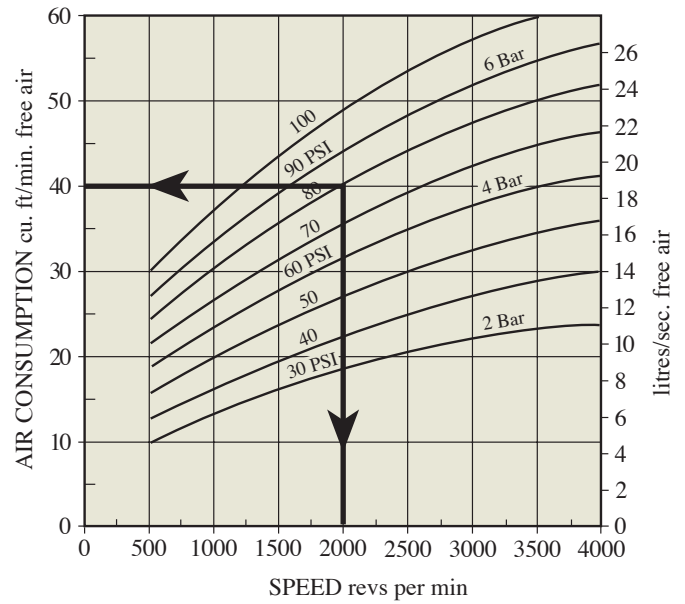

## MOTOR SELECTION

Motor performance can be derived from the above graphs as in the examples shown.

Where motors are not required to start under load, such as fan drives, selection may be made using either Graph 1 or Graph 3 using the required running torque or power only.

For applications where the motor starts under load, such as hoists, winches or track drives, the starting torque in Graph 2 must also be considered.

1. Running torque example: V2 at 80 psi gives 19 lbf.ins. torque at 2000 rpm.
2. Starting torque example: V2 at 80 psi gives 16 lbf.ins.
3. Output power example: V2 at 80 psi gives 0.6 hp at 2000 rpm.
4. Air consumption example: V2 at 80 psi and 2000 rpm requires 40 cu.ft./min. free air.



# DIMENSIONS V2

## MODEL VA2C Nema 56C configuration

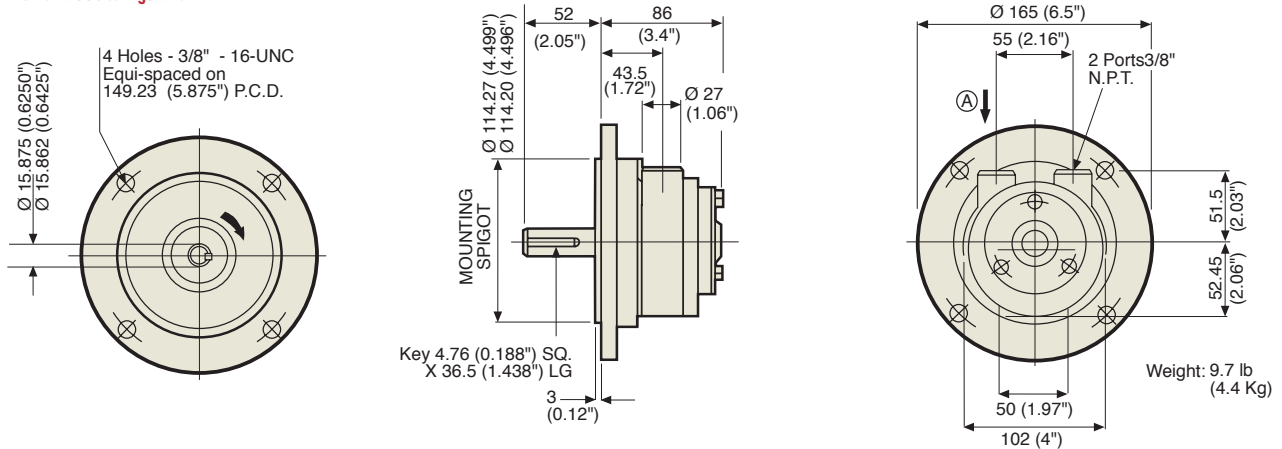

## MODEL VA2J Foot Mounting configuration

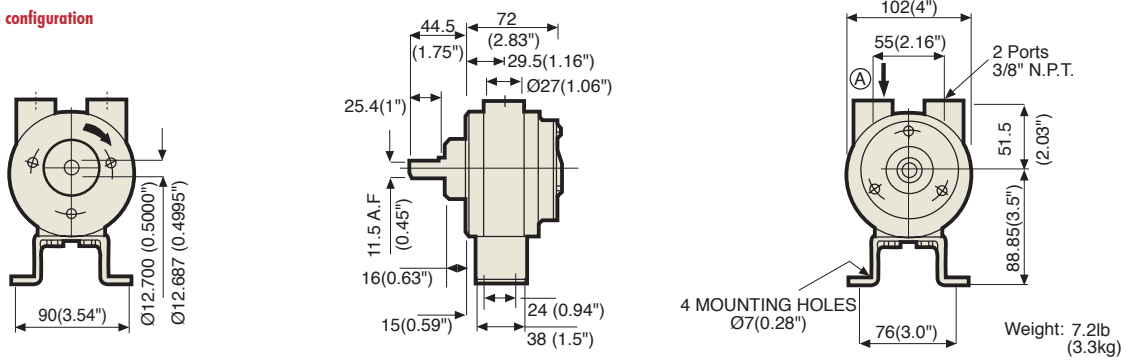

## MODEL VA2X Face Mounting configuration

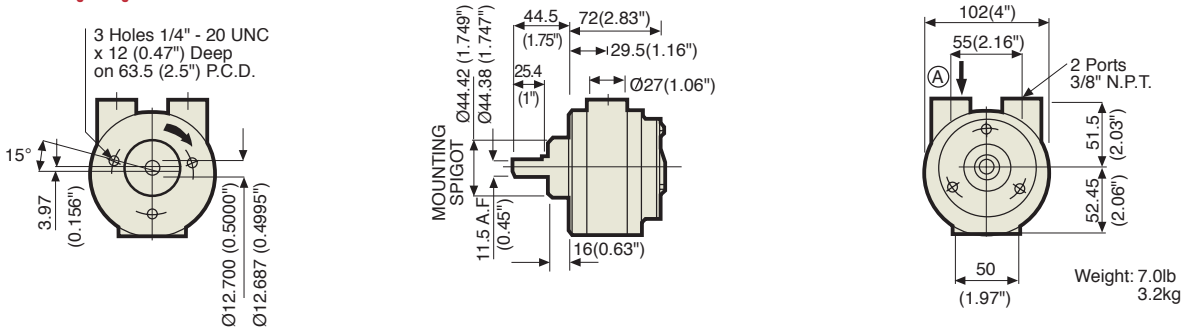

## MODEL VS2C D71 configuration

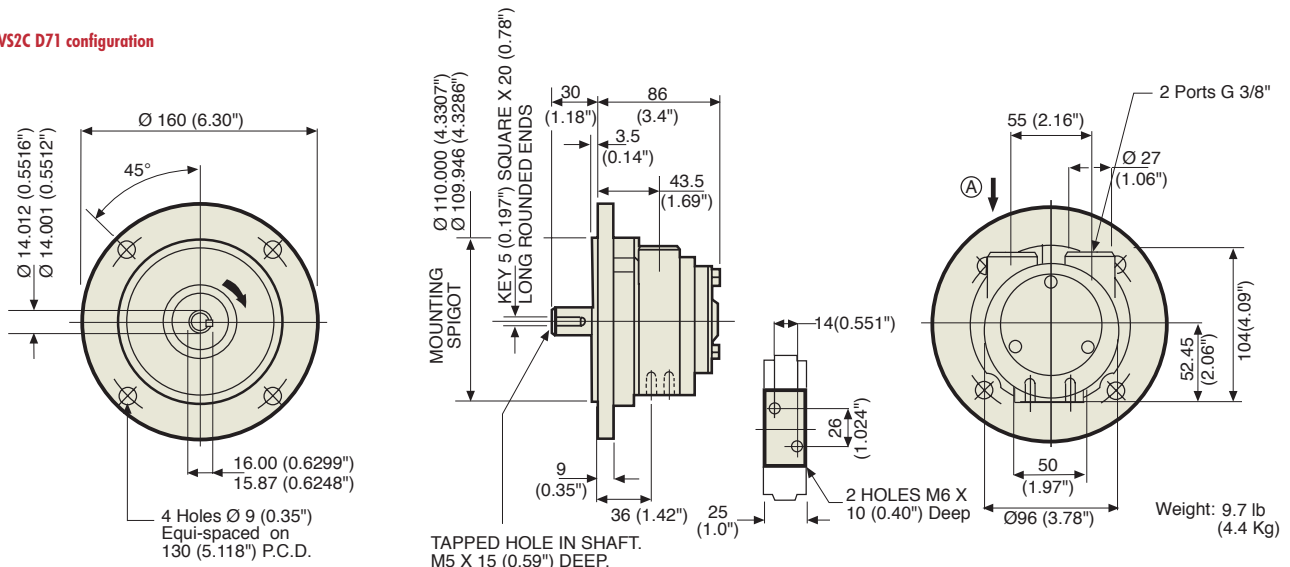

# PERFORMANCE V2 1.1 HP/0.82kW REVERSIBLE

**GRAPH 1 TORQUE - SPEED**

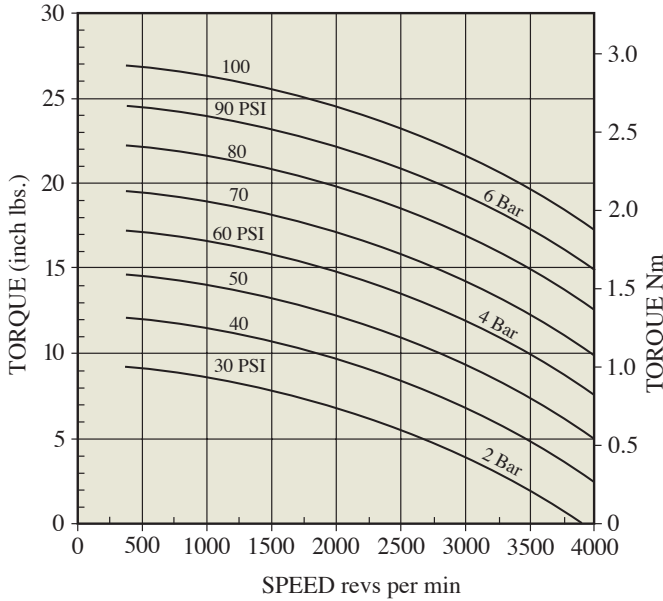

**GRAPH 2 STARTING TORQUE - PRESSURE**

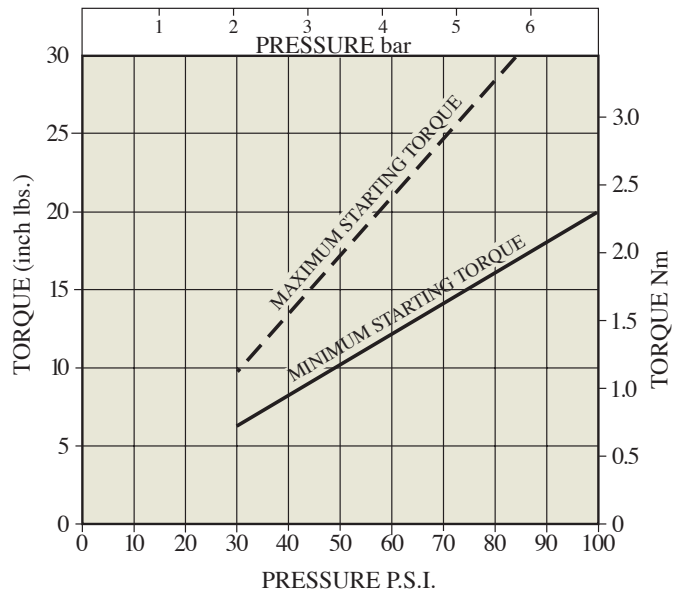

**GRAPH 3 POWER - SPEED**

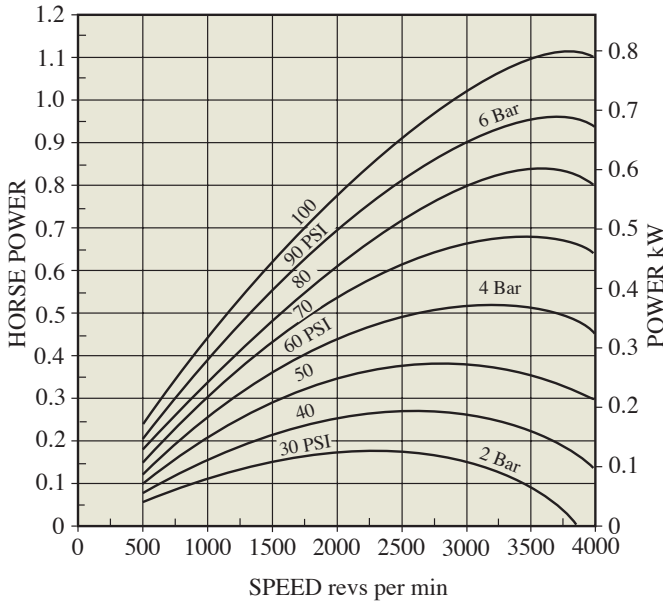

**GRAPH 4 CONSUMPTION - SPEED**

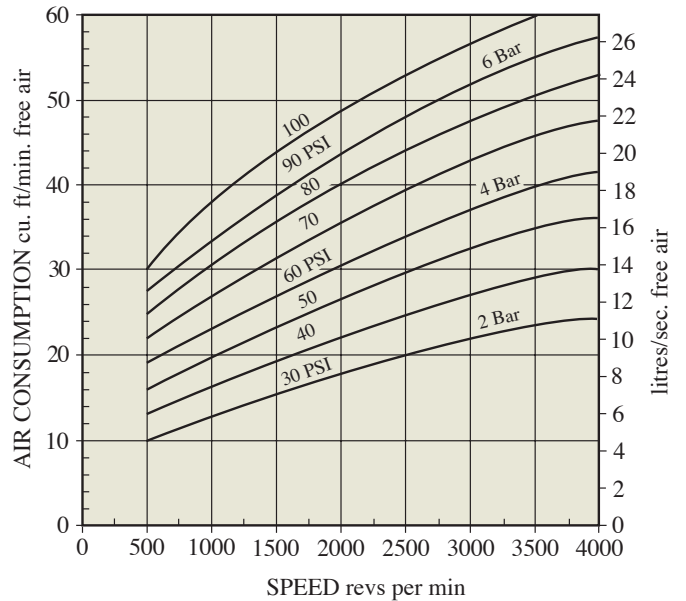

**Attitude:**

The motor can be operated in all positions.

**Airline filtration and lubrication:**

Use 64 micron filtration or better. Choose a lubricator suitable for the flow required. Prior to start up, inject oil into the inlet port.

**Lubricator drop rate:**

4-5 drops per minute continuous operation.  
9-12 drops per minute intermittent operation.

**Polar Moment of Inertia:**

0.47 lb.ins<sup>2</sup> (0.139 g.m<sup>2</sup>).

**Maximum overhung force on shaft:**

90 lbf (400N) In certain circumstances this may be extended. Consult your Globe Distributor. Axial loads should be kept to a minimum.

**Maximum temperatures:**

-4° to +176° Farenheit. (-20° to +80°C)

# DIMENSIONS V4

## MODEL VA4C Nema 56C configuration

4 Holes - 3/8" - 16-UNC  
Equi-spaced on  
149.23 (5.875") P.C.D.

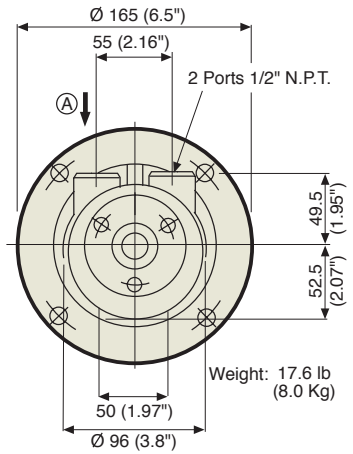
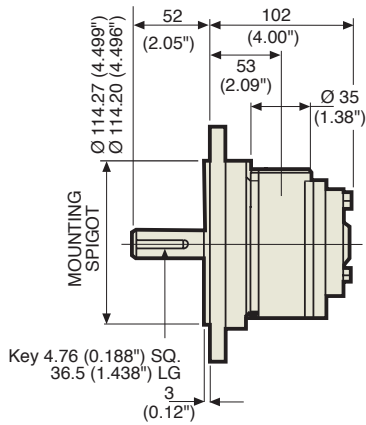
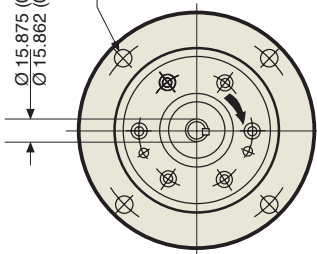

Weight: 17.6 lb  
(8.0 Kg)

## MODEL VA4J Foot Mounting configuration

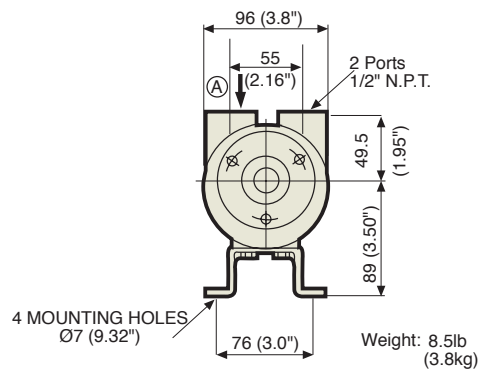
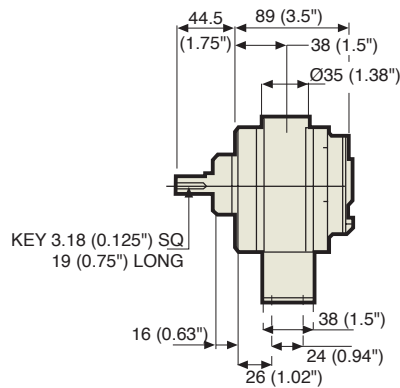
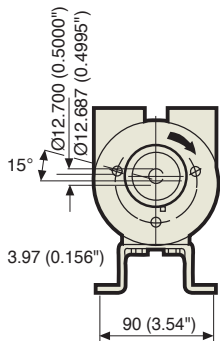

Weight: 8.5lb  
(3.8kg)

## MODEL VA4X Face Mounting configuration

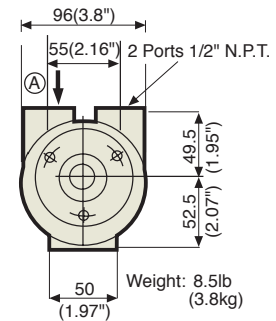
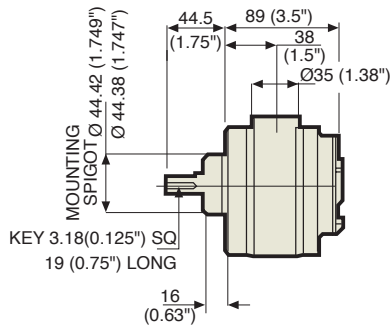
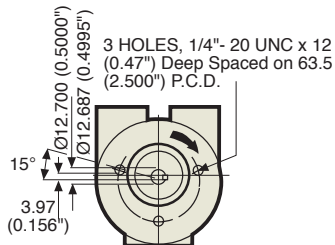

Weight: 8.5lb  
(3.8kg)

## MODEL VS4C D71 configuration

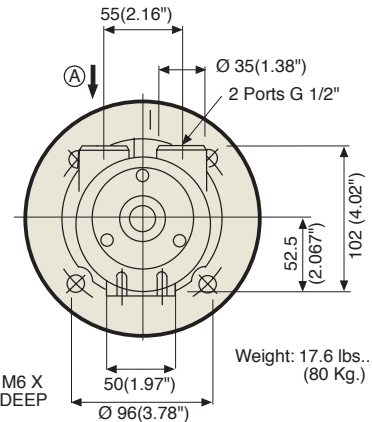
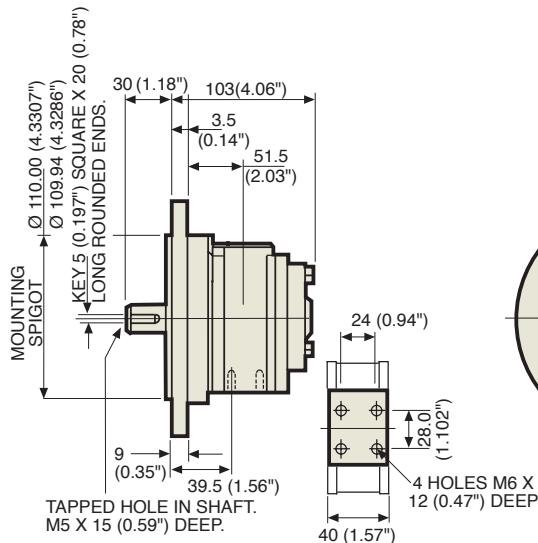
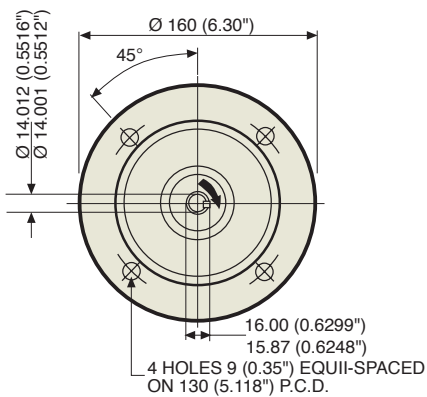

Weight: 17.6 lbs.,  
(80 Kg.)



# PERFORMANCE V4 2.8 HP/2.1 kW REVERSIBLE

**GRAPH 1 TORQUE - SPEED**

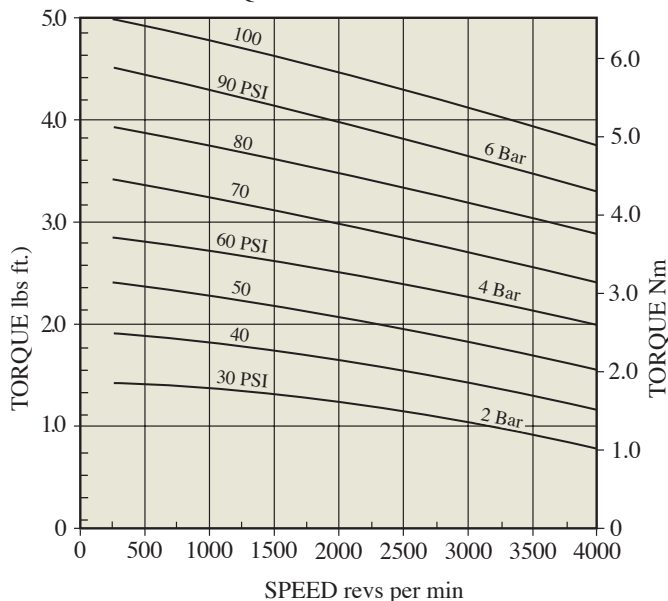

**GRAPH 2 STARTING TORQUE - PRESSURE**

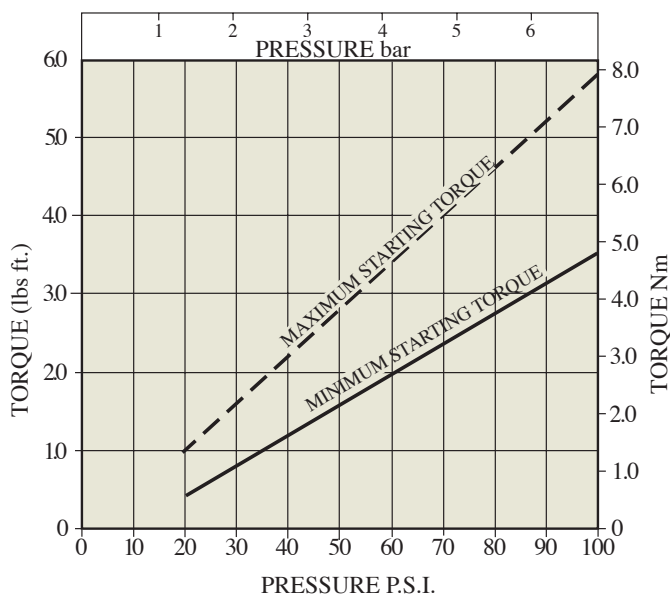

**GRAPH 3 POWER - SPEED**

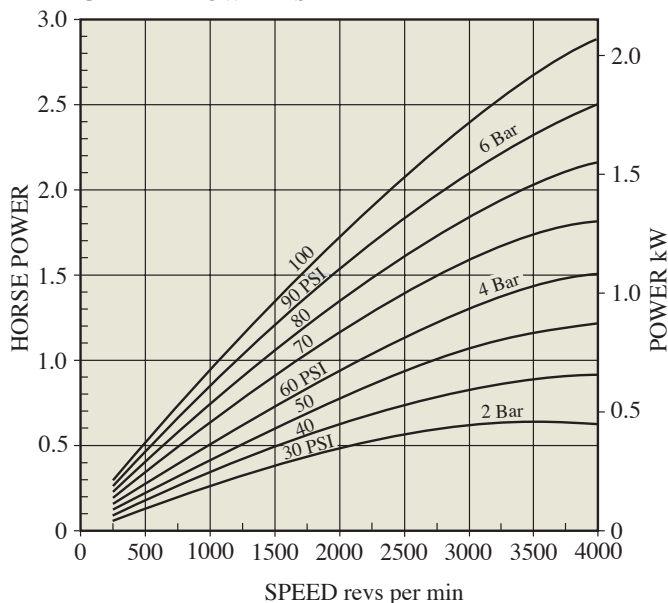

**GRAPH 4 CONSUMPTION - SPEED**

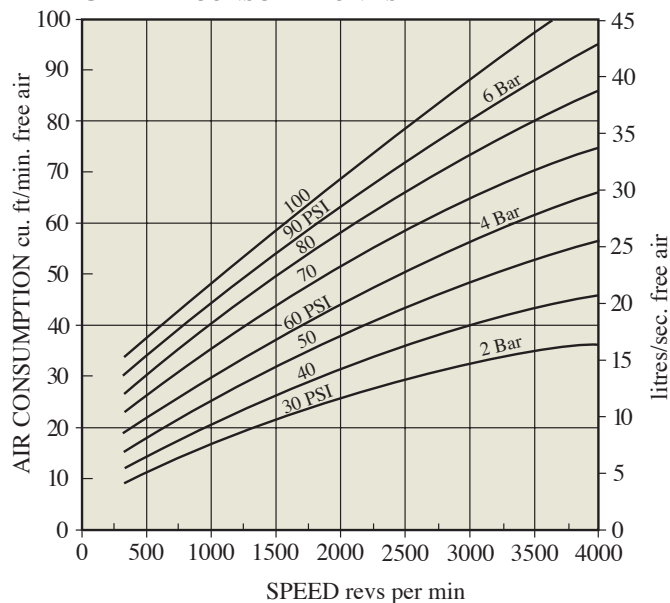

**Attitude:**

The motor can be operated in all positions.

**Airline filtration and lubrication:**

Use 64 micron filtration or better. Choose a lubricator suitable for the flow required. Prior to start up, inject oil into the inlet port.

**Lubricator drop rate:**

4-5 drops per minute continuous operation.  
9-12 drops per minute intermittent operation.

**Polar Moment of Inertia:**

0.77 lb.ins<sup>2</sup> (0.226 g.m<sup>2</sup>).

**Maximum overhung force on shaft:**

40 lbf (170N) In certain circumstances this may be extended. Consult your Globe Distributor. Axial loads should be kept down to a minimum.

**Maximum temperatures:**

-4° to +176° Farenheit. (-20° to +80°C )

# DIMENSIONS V6

## MODEL VA6C Nema 56C Configuration

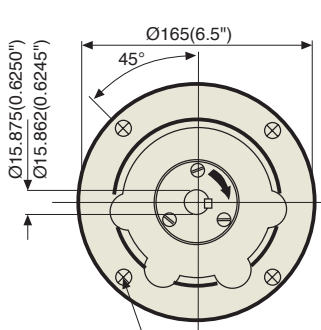

4 HOLES, 3/8"-16 UNC  
EQUISPACED ON 149.23  
(5.875") P.C.D.

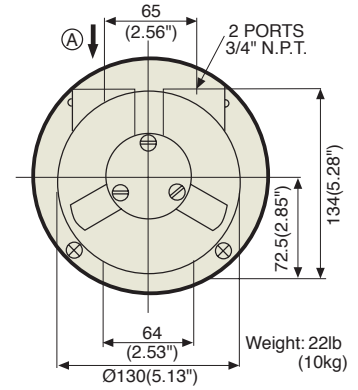
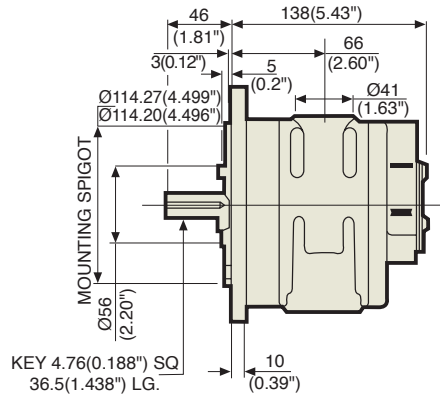

## MODEL VA6J Foot Mounting Configuration

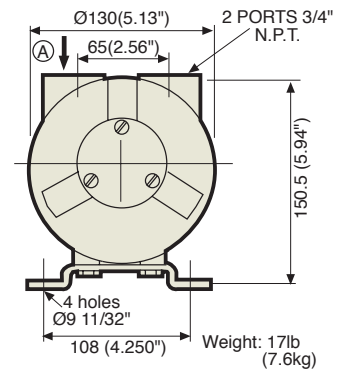
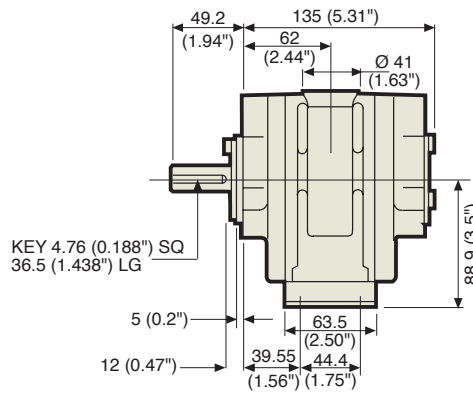
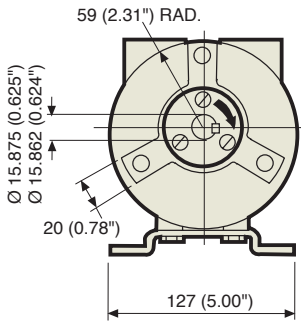

## MODEL VA6X Face Mounting Configuration

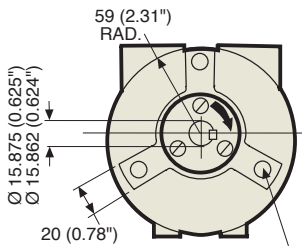

3 HOLES 5/16" - 18 UNC X 20 (25/32") DEEP  
EQUISPACED ON 101.6 (4.000) P.C.D.

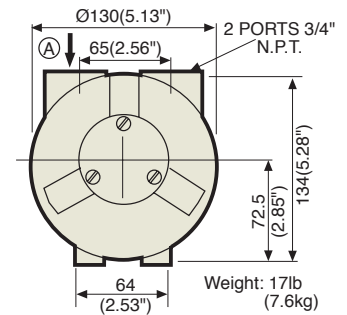
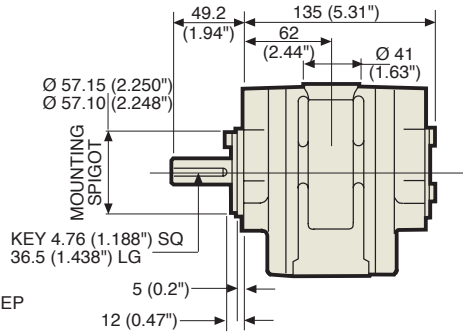

## MODEL VS6C D80 Configuration

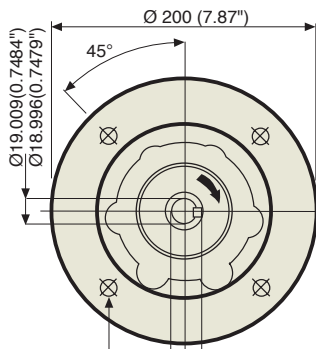

4 HOLES Ø12(0.47") EQUI-SPACED  
ON 165(6.496") P.C.D.

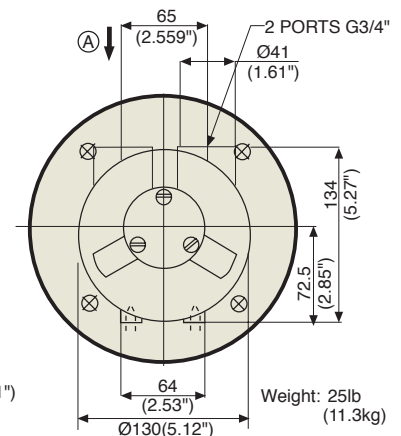
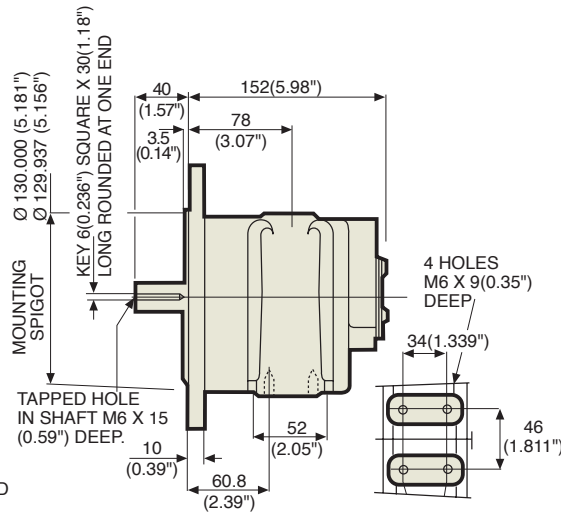

# PERFORMANCE V6 4.6 PEAK HP/3.4 kW REVERSIBLE

**GRAPH 1 TORQUE - SPEED**

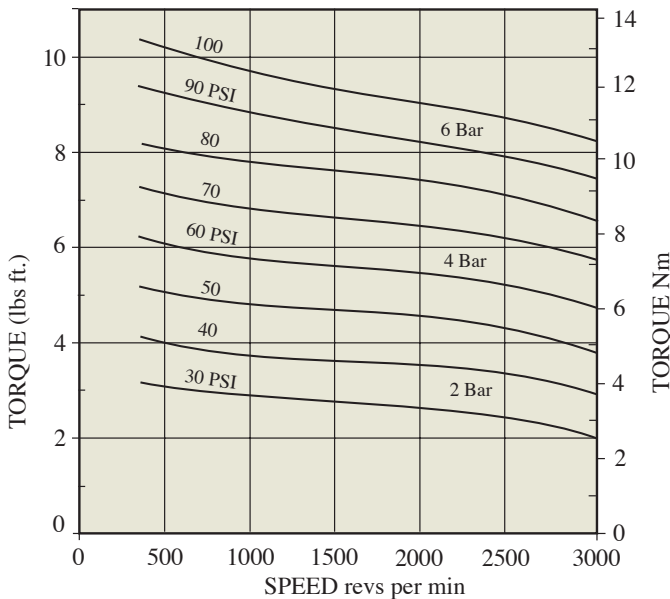

**GRAPH 2 STARTING TORQUE - PRESSURE**

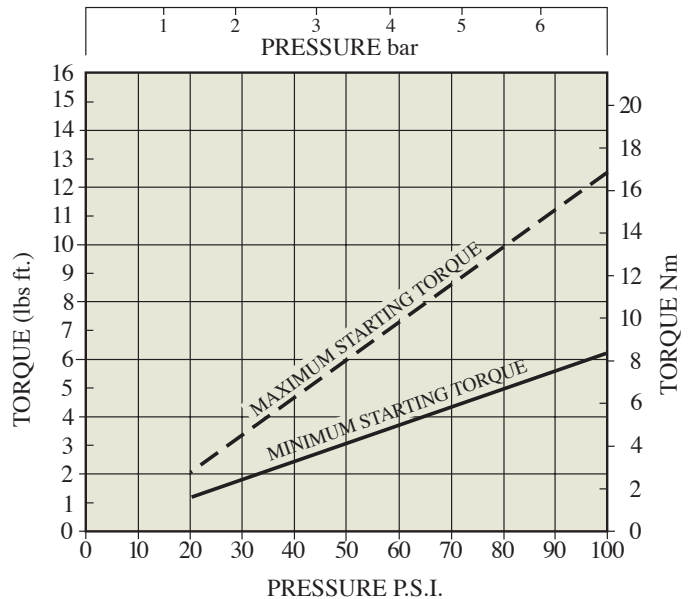

**GRAPH 3 POWER - SPEED**

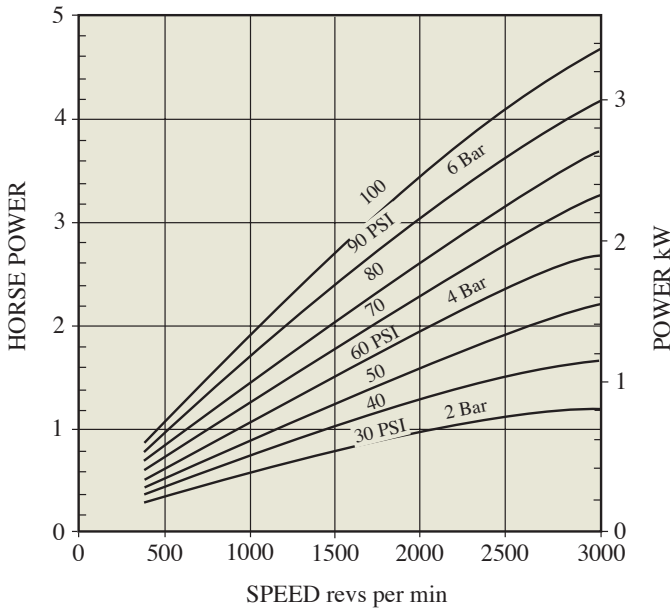

**GRAPH 4 CONSUMPTION - SPEED**

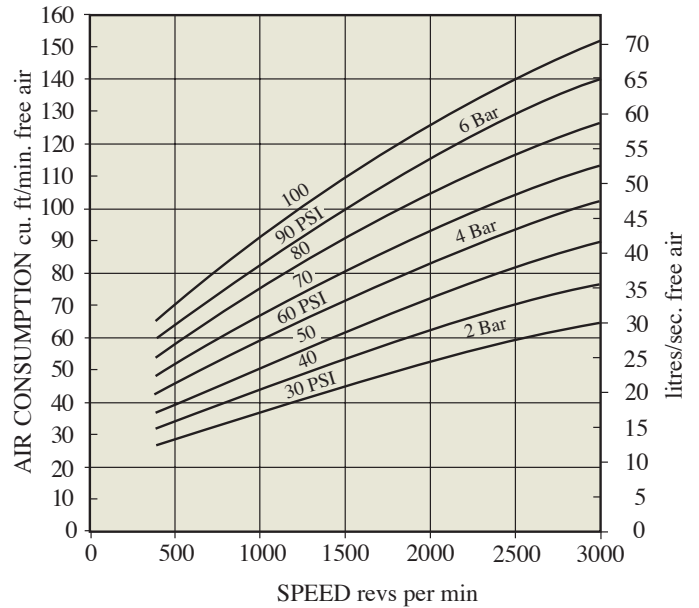

**Attitude:**

The motor can be operated in all positions.

**Airline filtration and lubrication:**

Use 64 micron filtration or better. Choose a lubricator suitable for the flow required. Prior to start up, inject oil into the inlet port.

**Lubricator drop rate:**

5-6 drops per minute continuous operation.  
10-12 drops per minute intermittent operation.

**Polar Moment of Inertia:**

1.56 lb.ins<sup>2</sup> (0.45 g.m<sup>2</sup>).

**Maximum overhung force on shaft:**

70 lbf (300N) In certain circumstances this may be extended. Consult your Globe Distributor. Axial loads should be kept down to a minimum.

**Maximum temperatures:**

-4° to +176° Fahrenheit. (-20° to +80°C)

# DIMENSIONS V8

## MODEL VA8C I45 TC Configuration

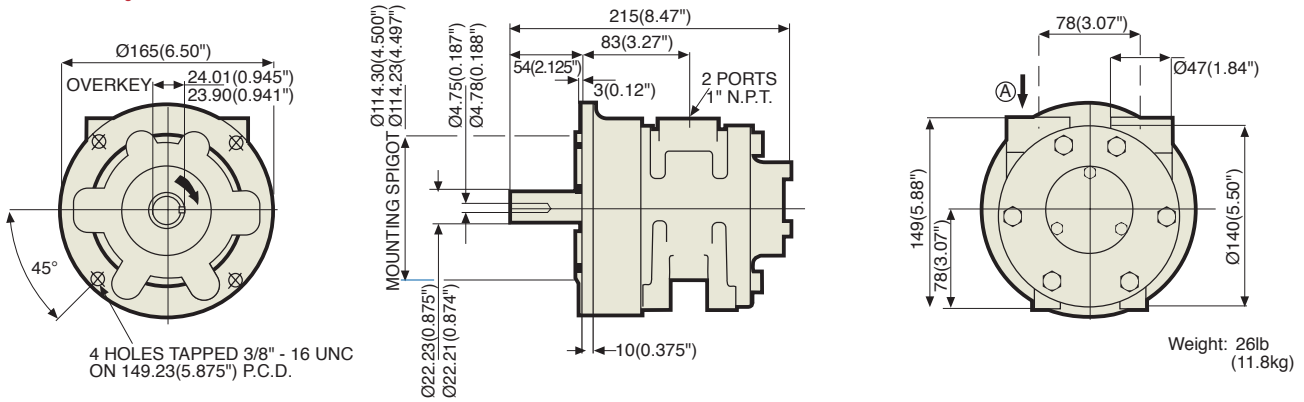

## MODEL VA8J Foot Mounting Configuration

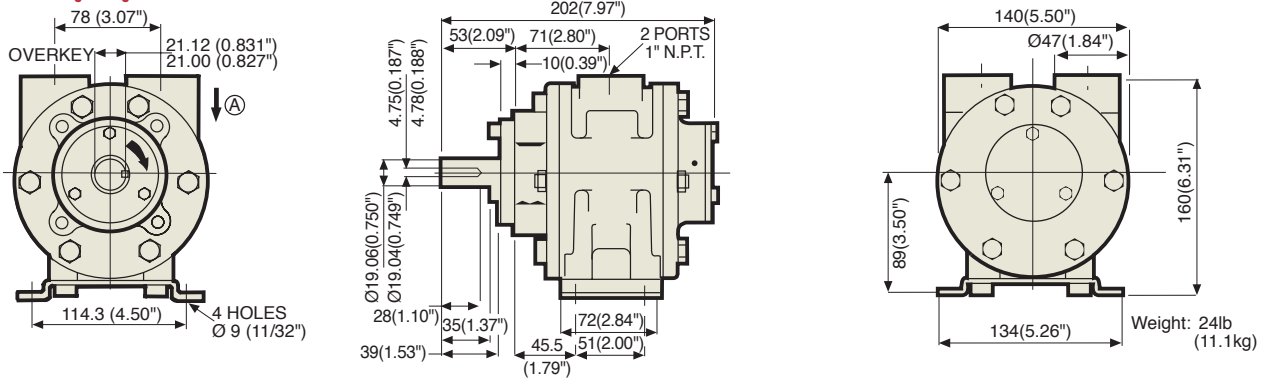

## MODEL VA8X Face Mounting Configuration

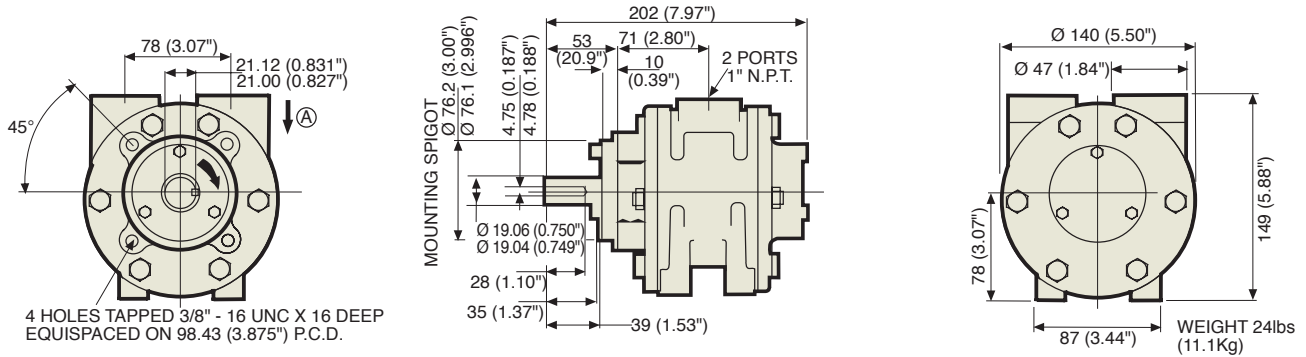

## MODEL VS8C D90 Flange Configuration

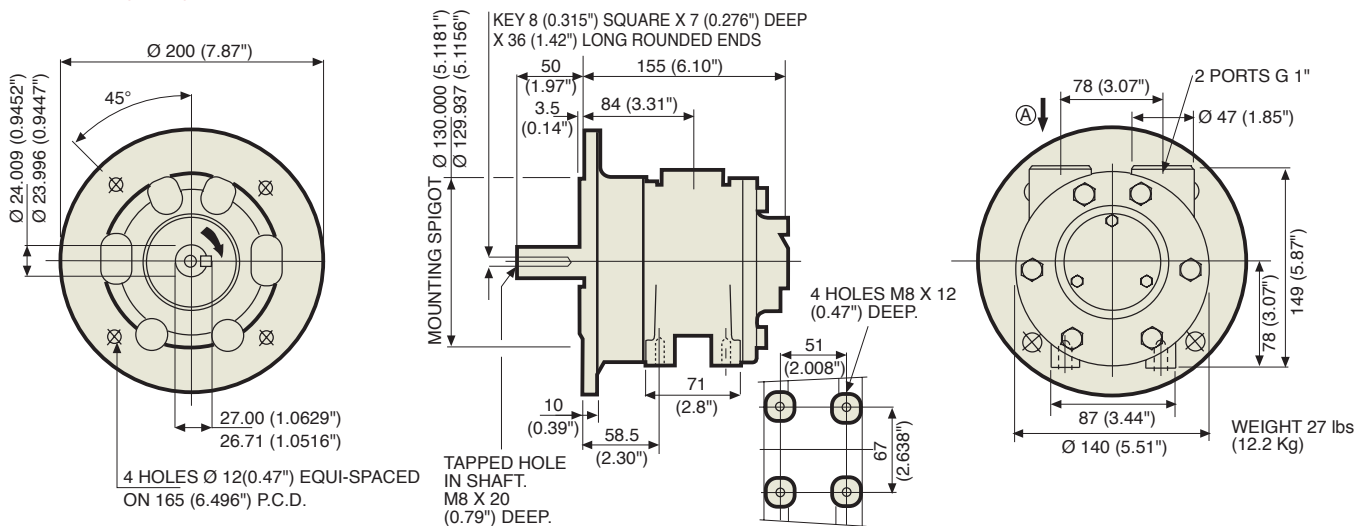



# PERFORMANCE V8 7.2 HP/5.4 kW REVERSIBLE

**GRAPH 1 TORQUE - SPEED**

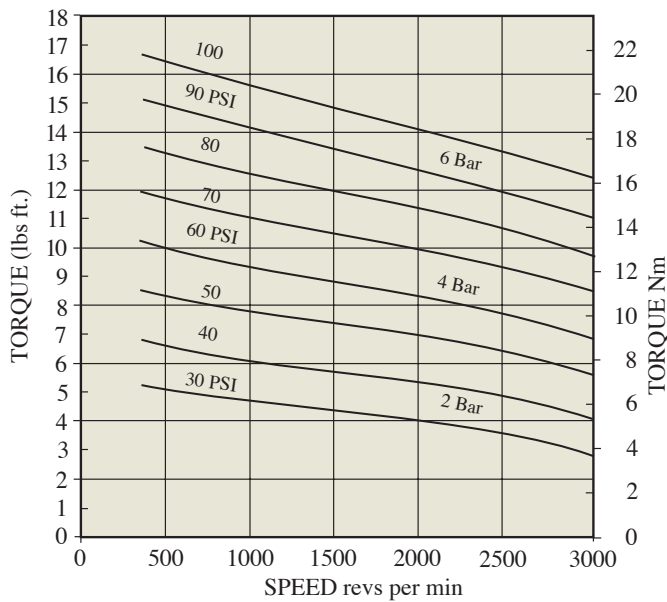

**GRAPH 2 STARTING TORQUE - PRESSURE**

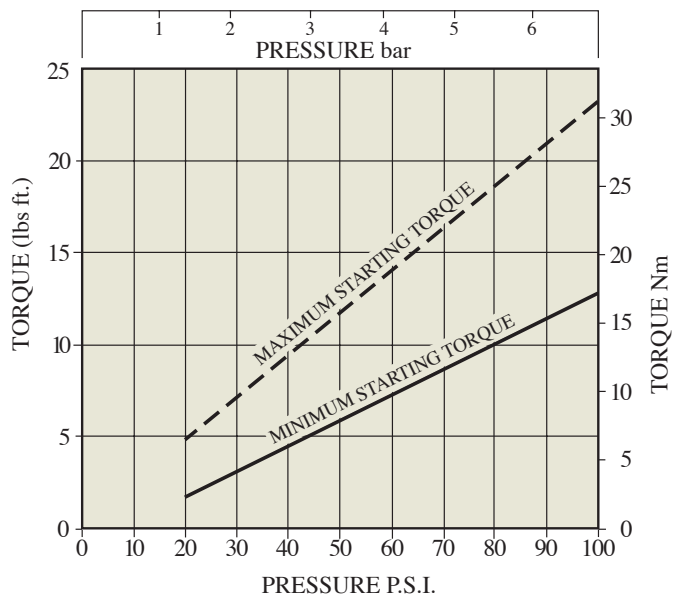

**GRAPH 3 POWER - SPEED**

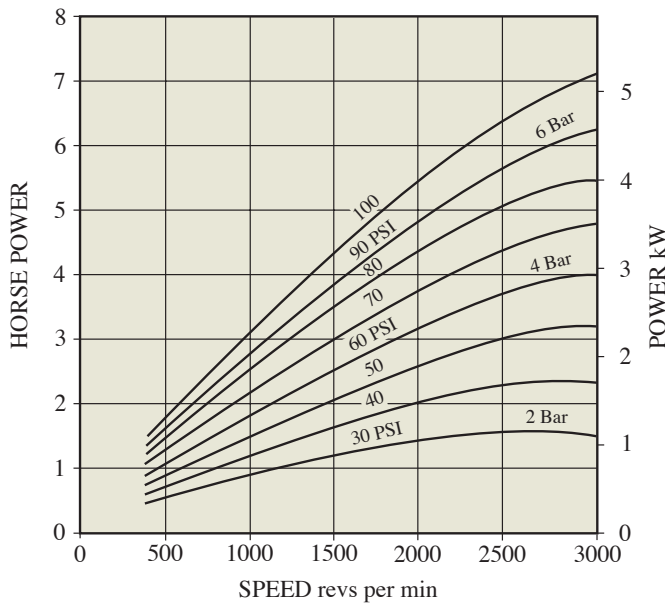

**GRAPH 4 CONSUMPTION - SPEED**

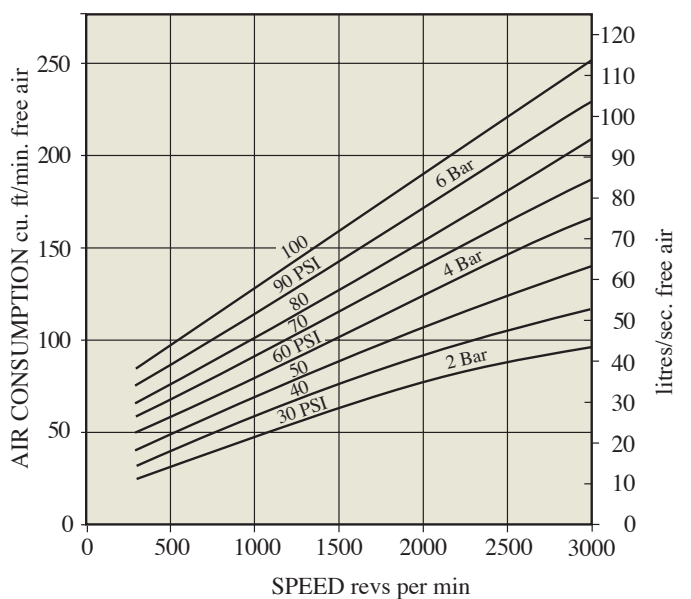

**Attitude:**

The motor can be operated in all positions.

**Airline filtration and lubrication:**

Use 64 micron filtration or better. Choose a lubricator suitable for the flow required. Prior to start up, inject oil into the inlet port.

**Lubricator drop rate:**

6-7 drops per minute continuous operation.  
12-15 drops per minute intermittent operation.

**Polar Moment of Inertia:**

3.5 lb.ins<sup>2</sup> (1.02 g.m<sup>2</sup>).

**Maximum overhung force on shaft:**

140 lbf (620N) In certain circumstances this may be extended. Consult your Globe Distributor. Axial loads should be kept down to a minimum.

**Maximum temperatures:**

-4° to +176° Farenheit. (-20° to +80°C)

# DIMENSIONS V10

## MODEL VA10C 145 TC Configuration

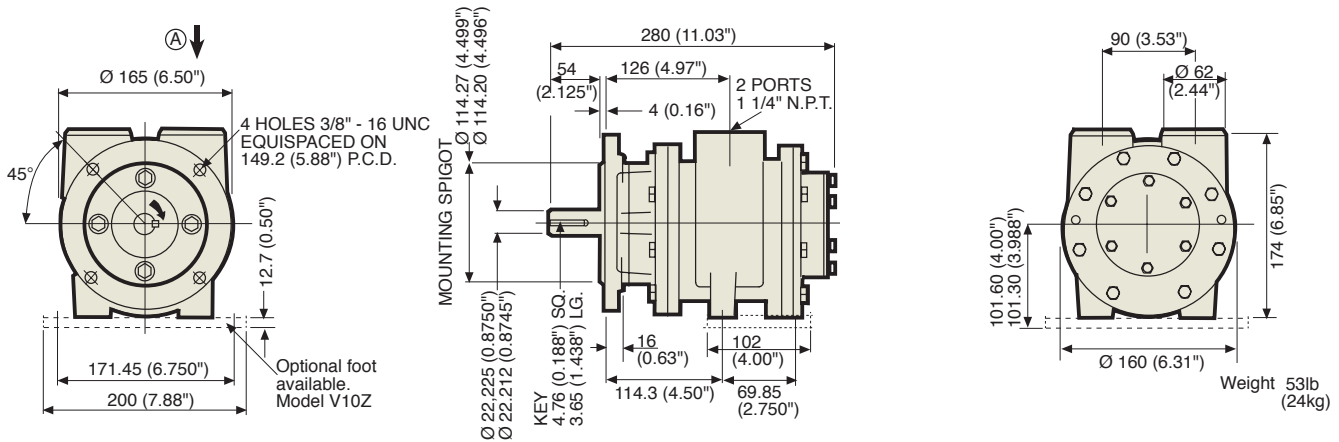

## MODEL VA10J Foot Mounting Configuration

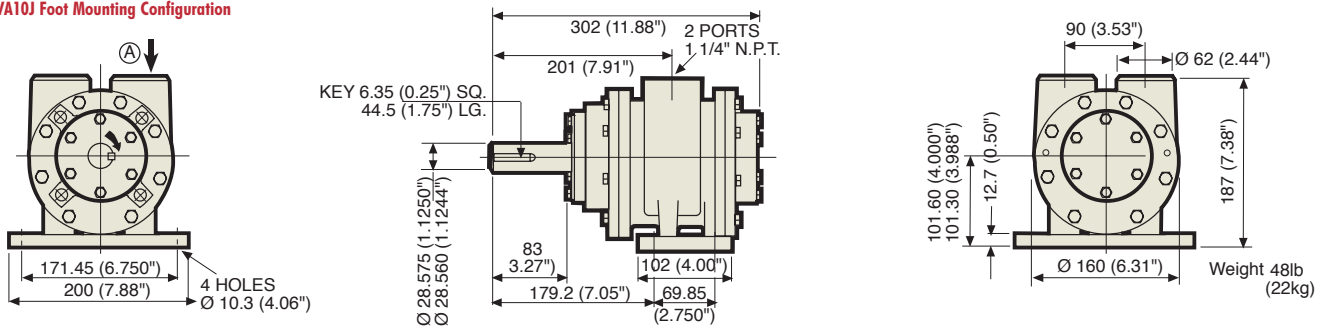

## MODEL VA10X Face Mounting Configuration

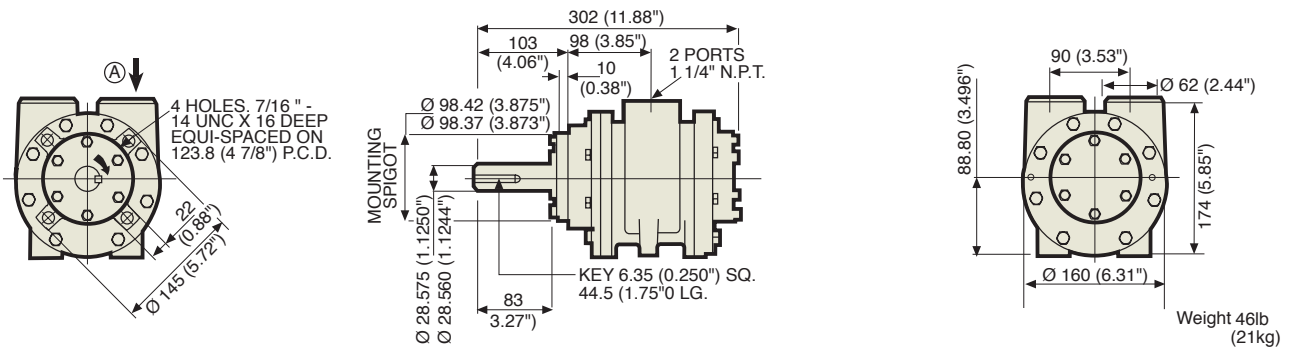

## MODEL VS10C D100 Flange Configuration

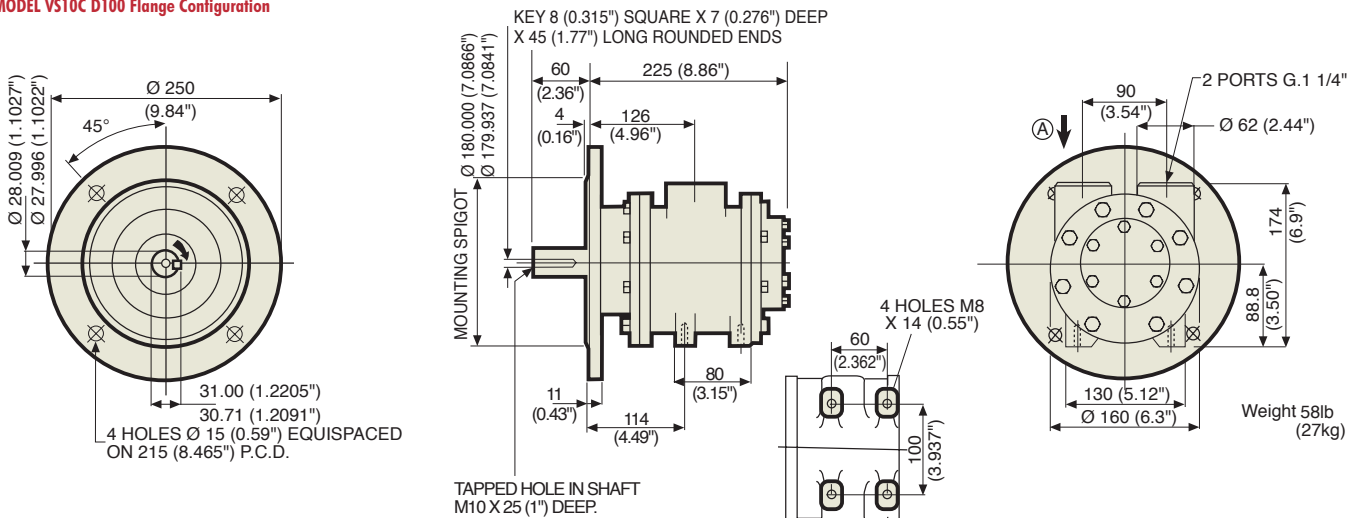

# PERFORMANCE V10 12.8 HP/9.5 kW REVERSIBLE

**GRAPH 1 TORQUE - SPEED**

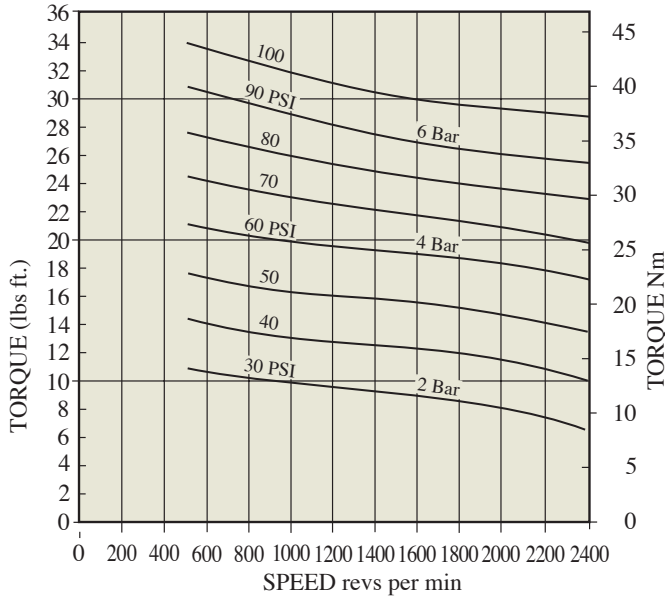

**GRAPH 2 STARTING TORQUE - PRESSURE**

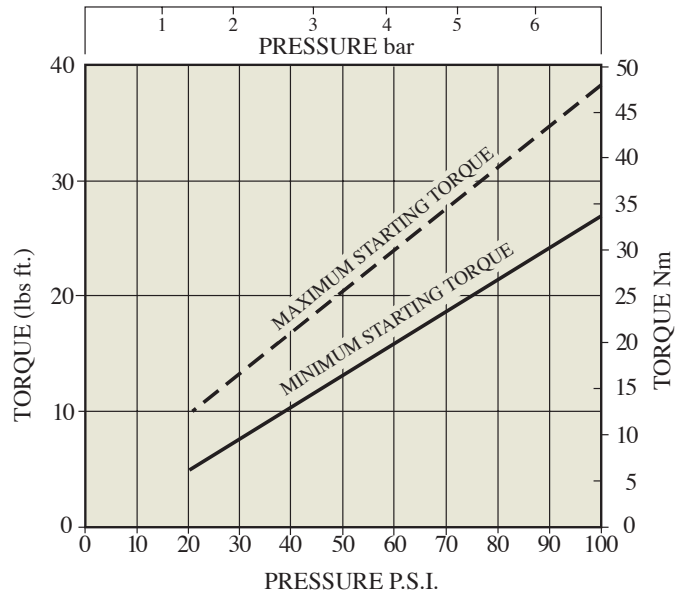

**GRAPH 3 POWER - SPEED**

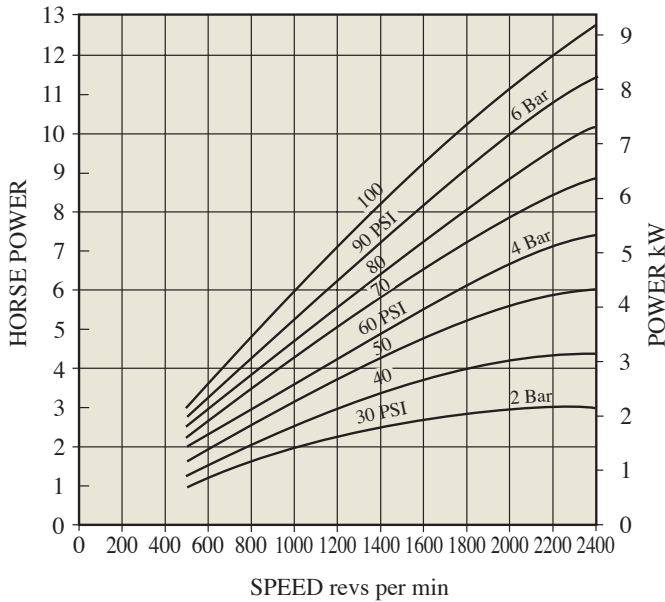

**GRAPH 4 CONSUMPTION - SPEED**

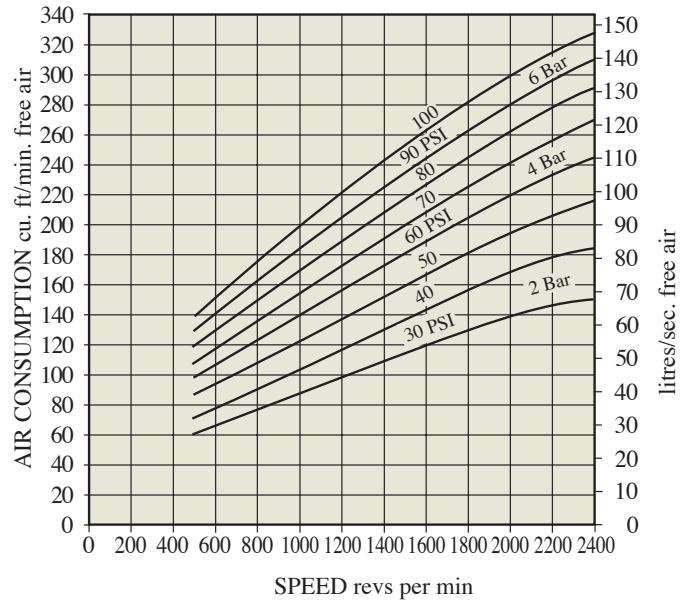

**Attitude:**

The motor can be operated in all positions.

**Airline filtration and lubrication:**

Use 64 micron filtration or better. Choose a lubricator suitable for the flow required. Prior to start up, inject oil into the inlet port.

**Lubricator drop rate:**

8-10 drops per minute continuous operation.  
14-16 drops per minute intermittent operation.

**Polar Moment of Inertia:**

30 lb.in<sup>2</sup> (8.8 g.m<sup>2</sup>).

**Maximum overhung force on shaft:**

400 lbf (1750N) In certain circumstances this may be extended. Consult your Globe Distributor. Axial loads should be kept down to a minimum.

**Maximum temperatures:**

-40° to +176° Farenheit. (-20° to +80°C)



# Globe Airmotors Program



## Turbine Motor

High lifetime of tools, up to 100.000 rpm. Power from 50 to 250 W.



## Compact Air Motor

Reversible, compact, available with a wide range of incorporated reduction unit. Power from 180 to 550 W.



## Vane Motor

Reversible, available in flange, foot, or face execution. Power from 0,44 to 9,5 kW.



## Vane Motor with Gearbox

Available with planetary, coaxial, or worm gearboxes. Also possible with pneumatic brake.



## Compact Piston Motor

High torque at low speed of rotation, very low air consumption and low noise level. Power from 110 to 460 W.

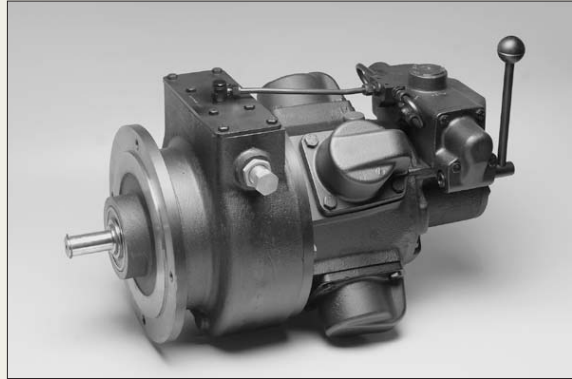

## Radial Piston Air Motor

Available with proportional hand or remotely controlled valve, pneumatic brake and all types of gearboxes. Power from 0,8 to 23 kW.

## DISTRIBUTOR



**GLOBE AIRMOTORS B.V.**

Eikenlaan 261e  
NL-2404 BP Alphen a/d Rijn  
Tel: (+31)-(0)172-426608  
Fax: (+31)-(0)172-426607  
Website: <http://www.globe-benelux.nl>  
E-mail: [info@globe-benelux.nl](mailto:info@globe-benelux.nl)