

# Liquid ring vacuum pumps

in compact design



## LEM 25, LEM 50

**Pressure range:** 33 to 1013 mbar  
**Suction volume flow:** 4 to 60 m<sup>3</sup>/h

### CONSTRUCTION

SIHI liquid ring vacuum pumps are displacement pumps of uncomplicated and robust construction with the following particular features:

- non-polluting due to nearly isothermal compression
- oil-free, as no lubrication in the working chamber
- handling of nearly all gases and vapours
- small quantities of entrained liquid can be handled
- easy maintenance and reliable operation
- low noise and nearly free from vibration
- wide choice of material, therefore applicable nearly everywhere
- shaft not contact with the medium
- protection against cavitation as standard
- incorporated dirt drain
- incorporated central drain
- no metallic contact of the rotating parts

The SIHI liquid ring vacuum pumps LEM are single-stage ones.

### APPLICATION

Handling and exhausting of dry and humid gases; entrained liquid can be handled during normal duty. The pumps are applied in all fields where a pressure of 33 to 900 mbar must be created by robust vacuum pumps.



### NOTE

During operation the pump must continuously be supplied with service liquid, normally water, in order to eliminate the heat resulting from the gas compression and to replenish the liquid ring, because part of the liquid is leaving the pump together with the gas. This liquid can be separated from the gas in a liquid separator (see catalogue part accessories).

It is possible to reuse the service liquid. The pumps are equipped with a device by which the contaminated service liquid can continuously be drained during operation (dirt drain), if necessary.

The direction of rotation is clockwise, when looking from the drive on the pump.

### GENERAL TECHNICAL DATA

| Pump Type  | Units               | LEM 25       | LEM 50 |
|--|---------------------|--------------|--------|
| Speed  | 50 Hz<br>60 Hz      | rpm          |        |
|  |                     | 2900<br>3500 |        |
| Maximum overpressure on compression                                | bar                 | 0.3          |        |
| Permissible pressure difference between suction and discharge side | max.<br>min.        | bar          |        |
|  |                     | 1.1<br>0.2   |        |
| Hydraulic test pressure (overpressure)                             | bar                 | 3            |        |
| Moment of inertia of rotating parts of pump and water content      | kg · m <sup>2</sup> | 0.003        | 0.0095 |
| Noise level at 80 mbar suction pressure                            | dB (A)              | 68           | 69     |
| Maximum gas temperature  | dry<br>saturated    | °C           |        |
|  |                     | 200<br>100   |        |
| Service liquid   | °C                  | 80           |        |
| Maximum permissible temperature                                    | mm <sup>2</sup> /s  | 10           |        |
| Minimum permissible temperature                                    | kg/m <sup>3</sup>   | 4            |        |
| Maximum viscosity  | litre               | 1200         |        |
| Maximum density  |                     | 0.3          | 0.4    |
| Liquid capacity up to middle of shaft                              | bar                 | 0.2          |        |
| Maximum flow resistance of the heat exchanger                      |                     |              |        |

In selecting a pump, avoid choosing one which is likely to be operating at a combination of its maximum permissible limits e.g. maximum viscosity and maximum permissible pressure difference.

## Materials

| Item  | COMPONENTS                             | MATERIALS<br>OK                      |
|-------|--|--------------------------------------|
| 10.10 | Vacuum casing                          | 0.6025                               |
| 10.90 | Central body                           |                                      |
| 13.70 | Guide disc                             |                                      |
| 23.50 | Vane wheel impeller                    | 1.4308                               |
| -     | Steel parts in contact with the medium | 1.4401                               |
| 43.30 | Standard mechanical seal               | Steatite / Carbon / Butadiene rubber |
| 75.40 | Valve balls                            | polyamide A                          |

## Cut-away diagram LEM 25, LEM 50

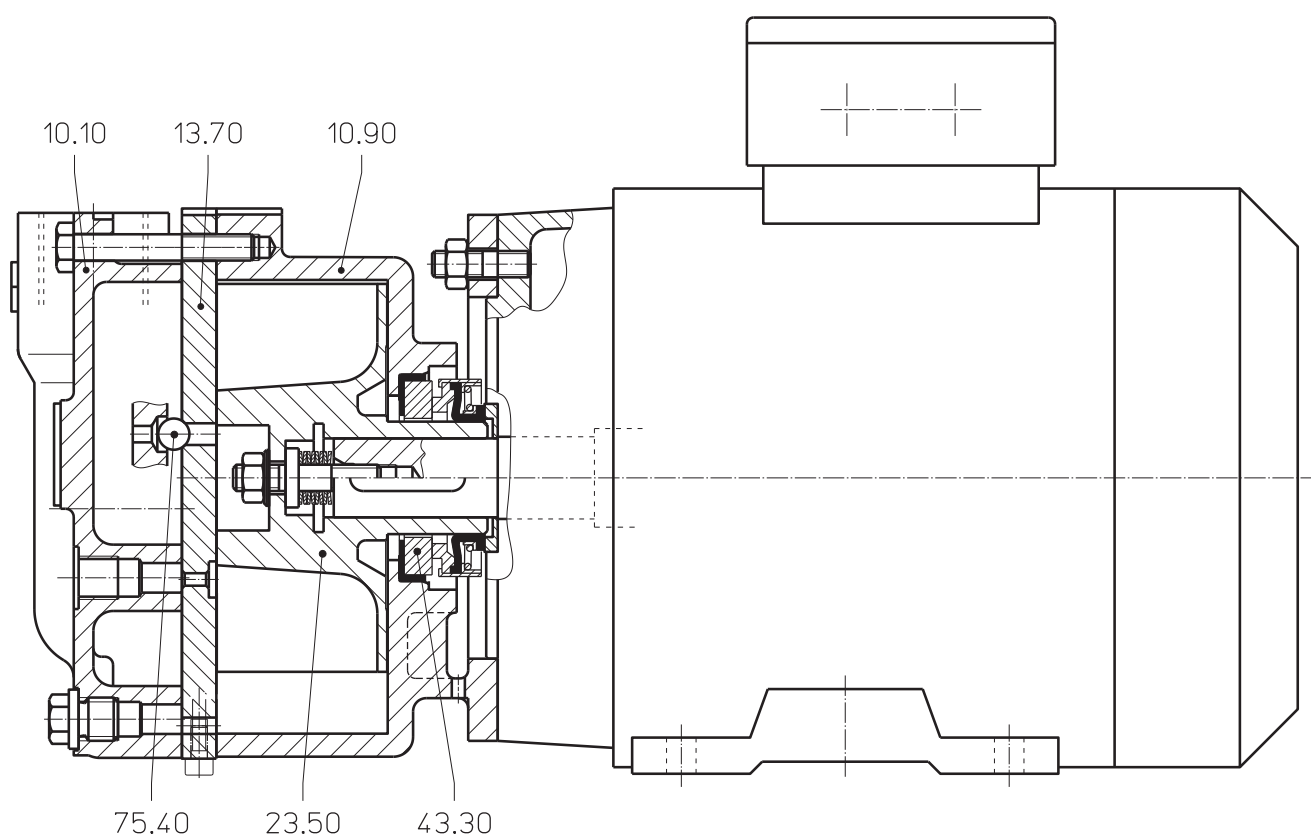

## Make-up Liquid Consumption in [m³/h] dependent upon suction pressure, speed, drive type and temperature difference

| suction pressure in [mbar] |             | 33                          |      |      | 120                         |      |      | 200                         |      |      | 400                         |      |      |      |      |      |      |
|----------------------------|-------------|-----------------------------|------|------|-----------------------------|------|------|-----------------------------|------|------|-----------------------------|------|------|------|------|------|------|
| pump type                  | speed [rpm] | KB                          |      | FB   | KB                          |      | FB   | KB                          |      | FB   | KB                          |      | FB   |      |      |      |      |
|                            |             | temperature difference [°C] |      |      | temperature difference [°C] |      |      | temperature difference [°C] |      |      | temperature difference [°C] |      |      |      |      |      |      |
|                            |             | 10                          | 5    | 2    | 10                          | 5    | 2    | 10                          | 5    | 2    | 10                          | 5    | 2    |      |      |      |      |
| LEM 25                     | 2800        | 0.04                        | 0.06 | 0.12 | 0.26                        | 0.05 | 0.08 | 0.13                        | 0.26 | 0.05 | 0.08                        | 0.14 | 0.26 | 0.05 | 0.08 | 0.12 | 0.2  |
|                            | 3500        | 0.05                        | 0.09 | 0.15 |                             | 0.06 | 0.10 | 0.16                        |      | 0.07 | 0.11                        | 0.16 |      | 0.06 | 0.10 | 0.14 |      |
| LEM 50                     | 2800        | 0.07                        | 0.13 | 0.23 | 0.5                         | 0.09 | 0.15 | 0.25                        | 0.48 | 0.09 | 0.15                        | 0.25 | 0.45 | 0.09 | 0.14 | 0.22 | 0.35 |
|                            | 3500        | 0.11                        | 0.18 | 0.29 |                             | 0.12 | 0.20 | 0.31                        |      | 0.13 | 0.20                        | 0.30 |      | 0.12 | 0.18 | 0.25 |      |

FB = total service liquid flow rate on once-through system

KB = flow of make-up water when combined with partial recirculation liquid at a temperature of 10 °C, 5 °C, 2 °C warmer than make-up water

## Performance Characteristics LEM 25

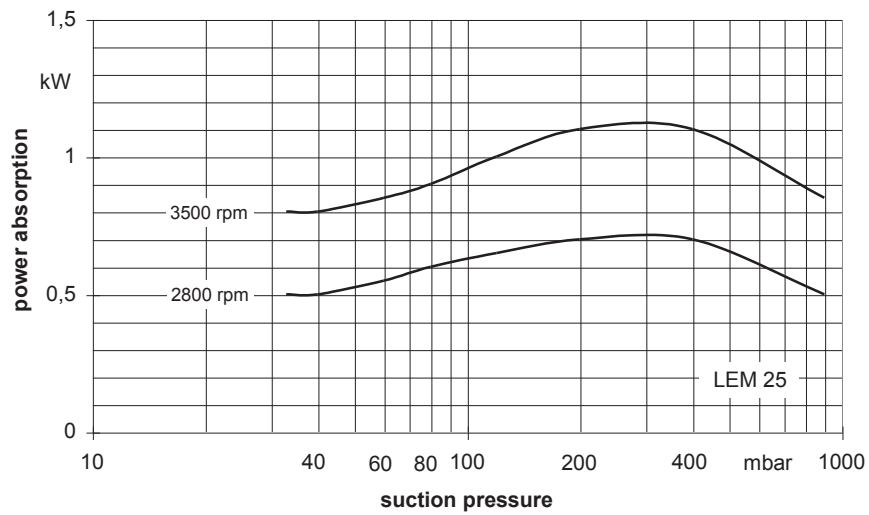
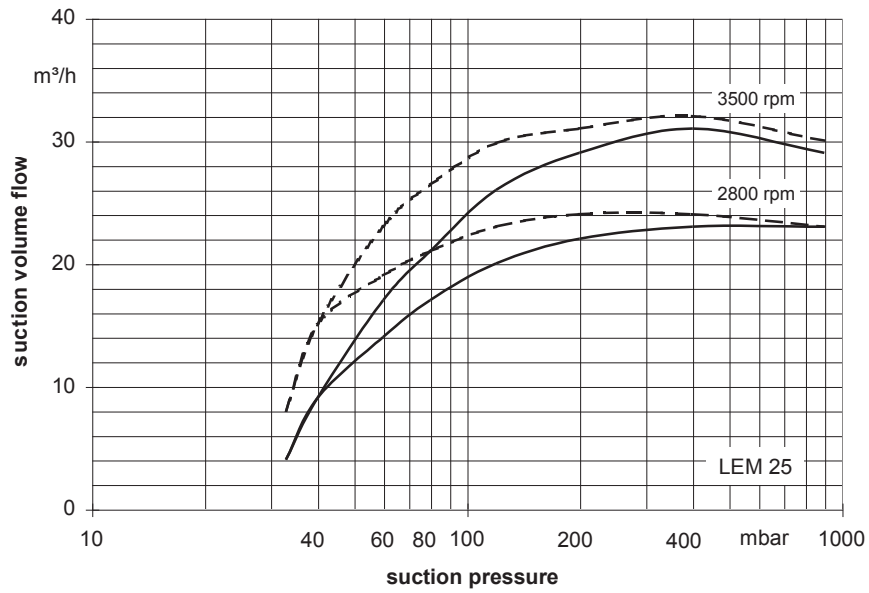

The operating data is valid under the following conditions:

- process media:
  - dry air: 20°C
  - steam saturated air: 20°C
- service liquid:
  - water: 15°C

Pressure of gas to be evacuated: 1013 mbar (atmospheric pressure)

The suction volume is related to the suction pressure.

Tolerance on operating data is 10%.

The maximum consumption of make-up water occurs at the lowest suction pressure.

# Performance Characteristics LEM 50

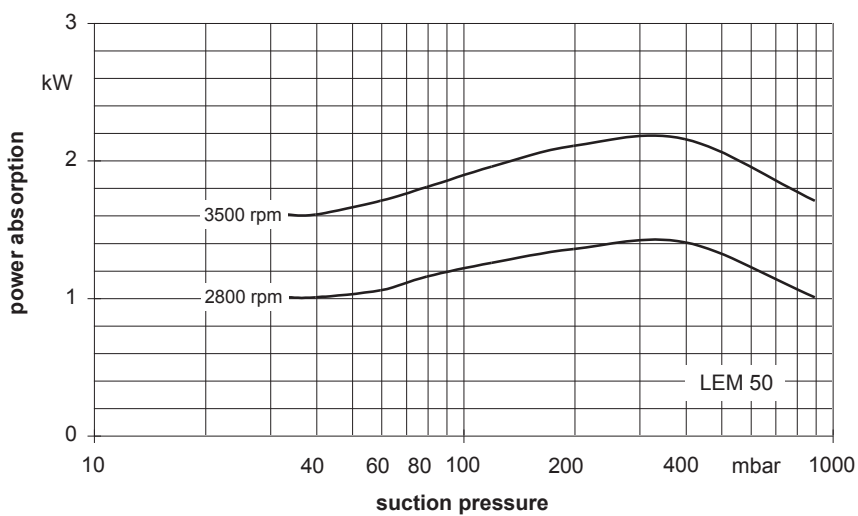
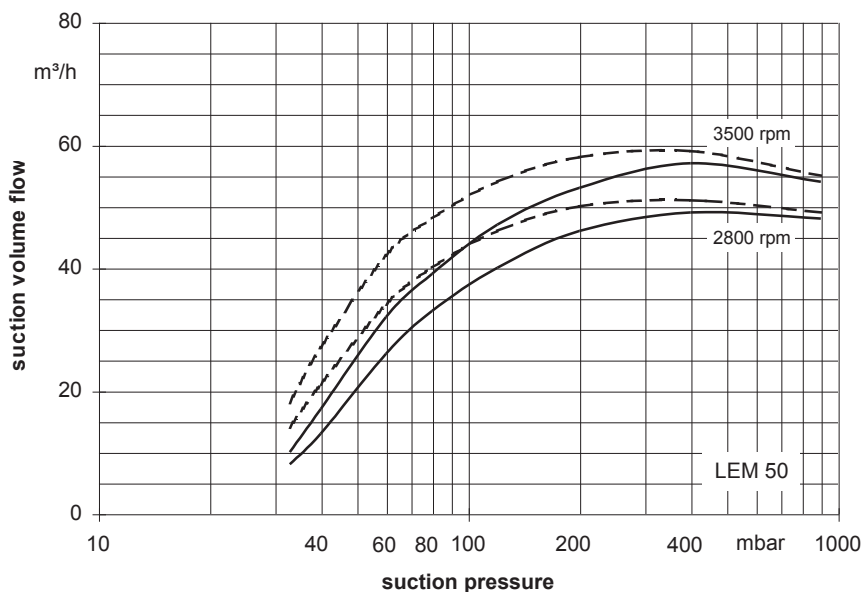

The operating data is valid under the following conditions:

- process media:
  - dry air: 20°C \_\_\_\_\_
  - steam saturated air: 20°C .....
- service liquid:
  - water: 15°C

Pressure of gas to be evacuated: 1013 mbar (atmospheric pressure)

The suction volume is related to the suction pressure.

Tolerance on operating data is 10%.

The maximum consumption of make-up water occurs at the lowest suction pressure.

**Dimensions LEM 25**

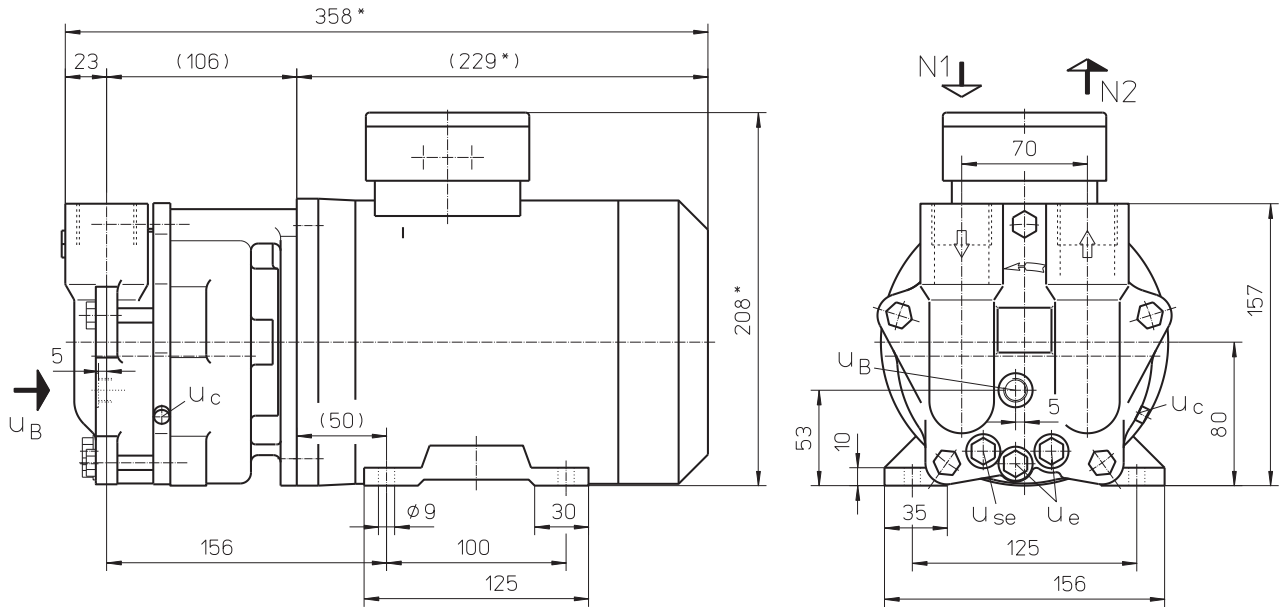

|        | electric motor IP 55 |       | approx. weight [kg] |
|--------|----------------------|-------|---------------------|
|        | size                 | kW    |                     |
| LEM 25 | 80                   | 50 Hz | 0.75                |
|        |                      | 60 Hz | 1.1                 |

other motors on request

\* dimensions dependent upon motor supplier

- N 1 = gas inlet G 1
- N 2 = gas outlet G 1
- u<sub>B</sub> = connection for service liquid G ¼
- u<sub>c</sub> = connection for protection against cavitation M5
- u<sub>e</sub> = connection for drain G ¼
- u<sub>se</sub> = connection for dirt drain G ¼

**Dimensions LEM 50**

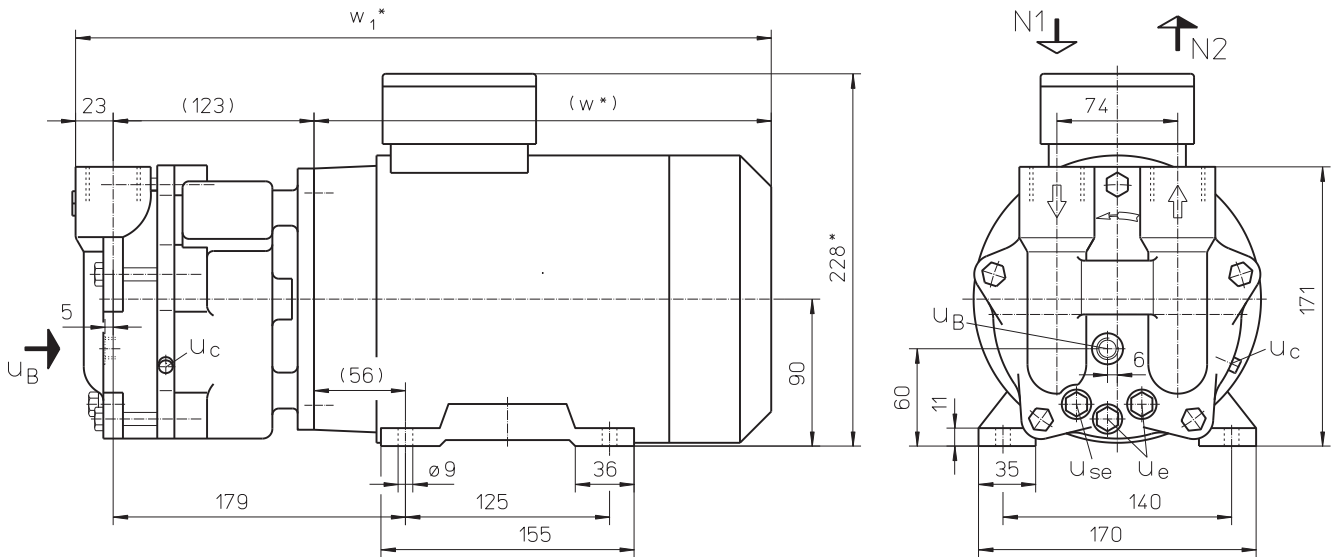

- N 1 = gas inlet G 1
- N 2 = gas outlet G 1
- u<sub>B</sub> = connection for service liquid G ¼
- u<sub>c</sub> = connection for protection against cavitation M5
- u<sub>e</sub> = connection for drain G ¼
- u<sub>se</sub> = connection for dirt drain G ¼

|        | electric motor IP 55 |       | w* [mm] | w1* [mm] | approx. weight [kg] |    |
|--------|----------------------|-------|---------|----------|---------------------|----|
|        | size                 | kW    |         |          |                     |    |
| LEM 50 | 90 L                 | 50 Hz | 1.5     | 270      | 416                 | 31 |
|        |                      | 60 Hz | 2.2     | 280      | 426                 | 37 |

other motors on request

\* dimensions dependent upon motor supplier

Arrangement drawing LEM 25, LEM 50

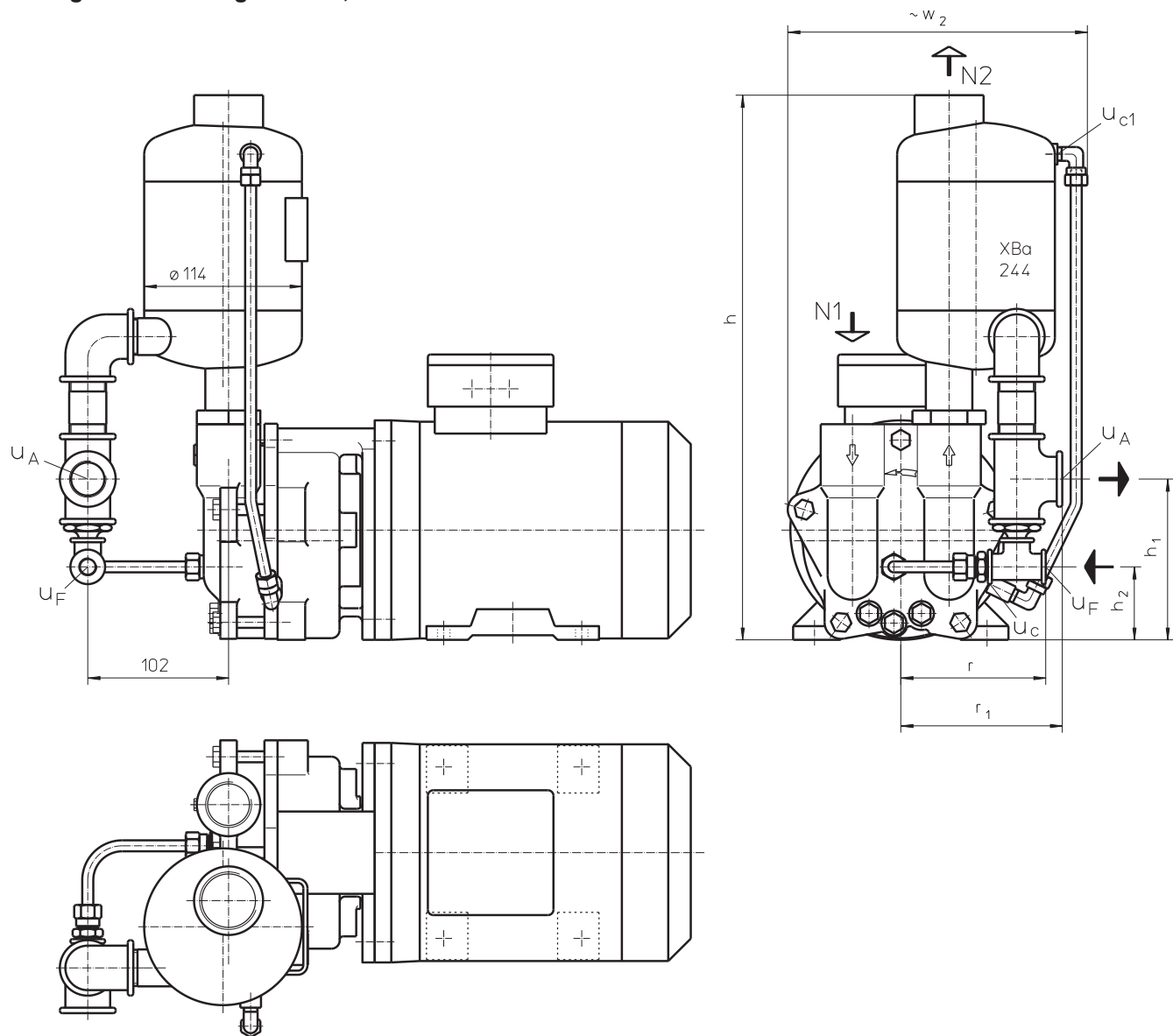

- N 1 = gas inlet G 1
- N 2 = gas outlet G 1 ¼
- u A = liquid overflow G ¾
- u c = connection for protection against cavitation M5
- u c1 = connection for protection against cavitation G 1/8
- u F = connection for make-up liquid G ¼

|        | h<br>[mm] | h <sub>1</sub><br>[mm] | h <sub>2</sub><br>[mm] | r<br>[mm] | r <sub>1</sub><br>[mm] | w <sub>2</sub><br>[mm] | approx. weight<br>[kg] |
|--------|-----------|------------------------|------------------------|-----------|------------------------|------------------------|------------------------|
| LEM 25 | 398       | 117                    | 54                     | 105       | 117                    | 217                    | 22                     |
| LEM 50 | 411       | 123                    | 60                     | 107       | 119                    | 225                    | 29                     |

## Data regarding the pump size - order notes

| range + size        | hydraulic + bearings   | shaft seal                                    | materials   | casing sealing |
|---------------------|--|---|---|----------------|
|                     | <ul style="list-style-type: none"> <li>A• hydraulic A</li> <li>•Z two grease lubricated antifriction bearings arranged in the motor</li> </ul> | X1L mechanical seal carbon / butadiene rubber | OK main parts out of cast iron, impeller in low alloyed steel | 0 liquid seal  |
| LEM $\frac{25}{50}$ | AZ   | X1L   | OK  | 0              |

## Motor Selection

For our products we offer a lot of different motor types.  
To identify the right motor please specify frequency, voltage and protection class.

### Example of an Order:

LEMA 25 AZ X1L OK 0 with 0.75 kW AC motor, 50 Hz, 230V Δ, IP55

## Accessories LEM 25, LEM 50

| Recommended Accessory                             | Material execution               |               | LEM 25                   | LEM 50            |
|---|----------------------------------|---------------|--------------------------|-------------------|
| <b>Top Mounted Liquid Separator</b>               |                                  | Type / weight | XBa 244 / 2.8 kg         |                   |
| Top mounted separator                             | 1.4571                           | SIHI-Part No. | 43 133 503               |                   |
| Service liquid pipework, standard execution       | Steel, galvanised<br>1.4571      | SIHI-Part No. | 20 072 997<br>20 072 998 |                   |
| Service liquid pipework, thermostatic control 24V | 1.0254 + Brass<br>1.4571 + Brass | SIHI-Part No. | on request<br>20 072 556 |                   |
| Cavitation protection pipework                    | Steel, galvanised<br>1.4571      | SIHI-Part No. | 20 050 496<br>20 050 589 |                   |
| <b>Sterling SIHI – Gas Ejector</b>                |                                  |               |                          |                   |
| see Technical Catalogue – Gas Ejector             |                                  |               |                          |                   |
| at service liquid temperature 15 °C               |                                  | Type / weight | GEV 25 A / 1.1 kg        | GEV 50 A / 1.1 kg |
| at service liquid temperature 30 °C               |                                  | Type / weight | GEV 25 A / 1.1 kg        | GEV 50 A / 1.1 kg |
| <b>Sterling SIHI – Non Return Ball Valve</b>      |                                  | Size / weight | G1 / 0.7 kg              |                   |
|   | Brass + Butadiene rubber         | SIHI-Part No. | 20 044 637               |                   |
|   | Brass + Teflon                   |               | 20 044 639               |                   |
|   | 1.4571 + Teflon                  |               | 20 072 807               |                   |

Any changes in the interest of the technical development are reserved.

### Sterling SIHI GmbH

Lindenstraße 170, D-25524 Itzehoe, Germany  
Telephone +49 (0) 48 21 / 7 71-01, Fax +49 (0) 48 21 / 7 71-274  
www.sihi.com