

# Liquid ring vacuum pumps

in compact design



## LEM 91, LEM 126, LEM 161 LEL 91, LEL 126, LEL 161 with flange connection

**Pressure range:** 33 to 1013 mbar  
**Suction volume flow:** 24 to 195 m<sup>3</sup>/h

### CONSTRUCTION

SIHI liquid ring vacuum pumps are displacement pumps of uncomplicated and robust construction with the following particular features:

- non-polluting due to nearly isothermal compression
- oil-free, as no lubrication in the working chamber
- handling of nearly all gases and vapours
- small quantities of entrained liquid can be handled
- easy maintenance and reliable operation
- low noise and nearly free from vibration
- protection against cavitation as standard
- incorporated dirt drain
- incorporated central drain
- no metallic contact of the rotating parts

The SIHI liquid ring vacuum pumps LEM/LEL are single-stage ones.

### APPLICATION

Handling and exhausting of dry and humid gases; entrained liquid can be handled during normal duty. The pumps are applied in all fields where a pressure of 33 to 900 mbar must be created by robust vacuum pumps.



### NOTE

During operation the pump must continuously be supplied with service liquid, normally water, in order to eliminate the heat resulting from the gas compression and to replenish the liquid ring, because part of the liquid is leaving the pump together with the gas. This liquid can be separated from the gas in a liquid separator (see catalogue part accessories).

It is possible to reuse the service liquid. The pumps are equipped with a device by which the contaminated service liquid can continuously be drained during operation (dirt drain), if necessary.

The direction of rotation is clockwise, when looking from the drive on the pump.

### GENERAL TECHNICAL DATA

Pump type	unit	LEM 91 LEL 91	LEM 126 LEL 126	LEM 161 LEL 161
Speed	50 Hz rpm 60 Hz rpm	2900 3500		1450 1750
Maximum overpressure on compression	bar	LEM 0.3 / LEL 0.5		
Permissible pressure difference between suction and discharge side	max. min. bar	LEM 1.1 / LEL 1.3 0.2		
Hydraulic test pressure (overpressure)	bar	3		
Moment of inertia of rotating parts of pump and water content	kg · m <sup>2</sup>	0.007	0.009	0.070
Noise level at 80 mbar suction pressure	dB (A)	72 (67)*		65
Maximum gas temperature	dry saturated °C °C	200 100		
Service liquid				
Maximum permissible temperature	°C	80		
Minimum permissible temperature	°C	10		
Maximum viscosity	mm <sup>2</sup> /s	4		
Maximum density	kg/m <sup>3</sup>	1200		
Liquid capacity up to middle of shaft	litre	0.5	0.6	2.0
Maximum flow resistance of the heat exchanger	bar	0.2		

The combination of several limiting values is not admissible.

\* value in parenthesis for measuring with sound insulation cup

## Materials

Item	COMPONENTS	MATERIALS OK
10.10	Vacuum casing	0.6025
13.70	Guide disc	1.4301
16.10	Cover	
21.00 *	Shaft	1.4571
23.50	Vane wheel impeller	1.4308
33.01 *	Bearing bracket	0.6025
34.01 *	Motor carrier	
43.30	Mechanical seal	Carbon / ceramic / Viton
75.40	Valve balls	Polyamide A

\* only for LEL 91, 126, 161

## Cut-away diagram LEM 91, 126, 161

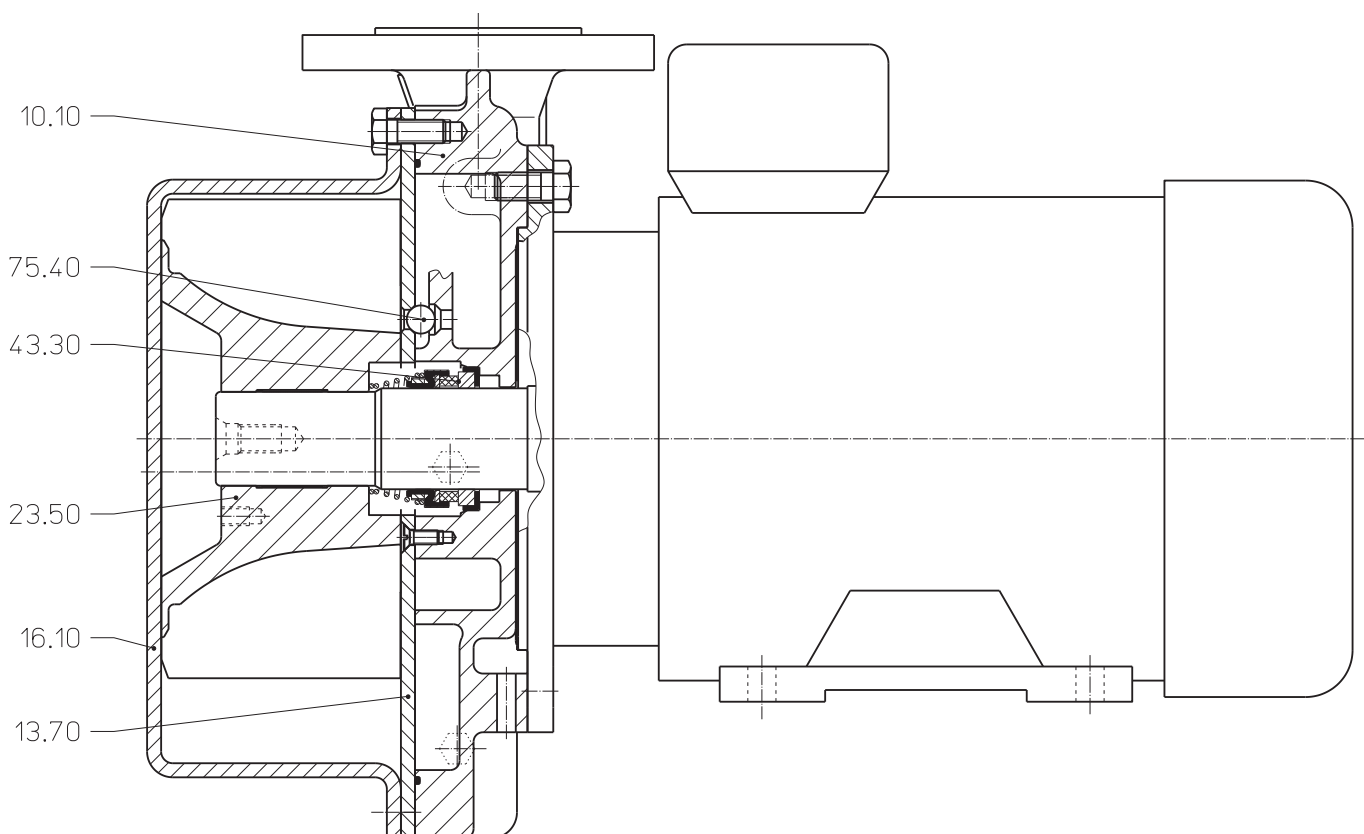

**Cut-away diagram LEL 91, 126, 161**

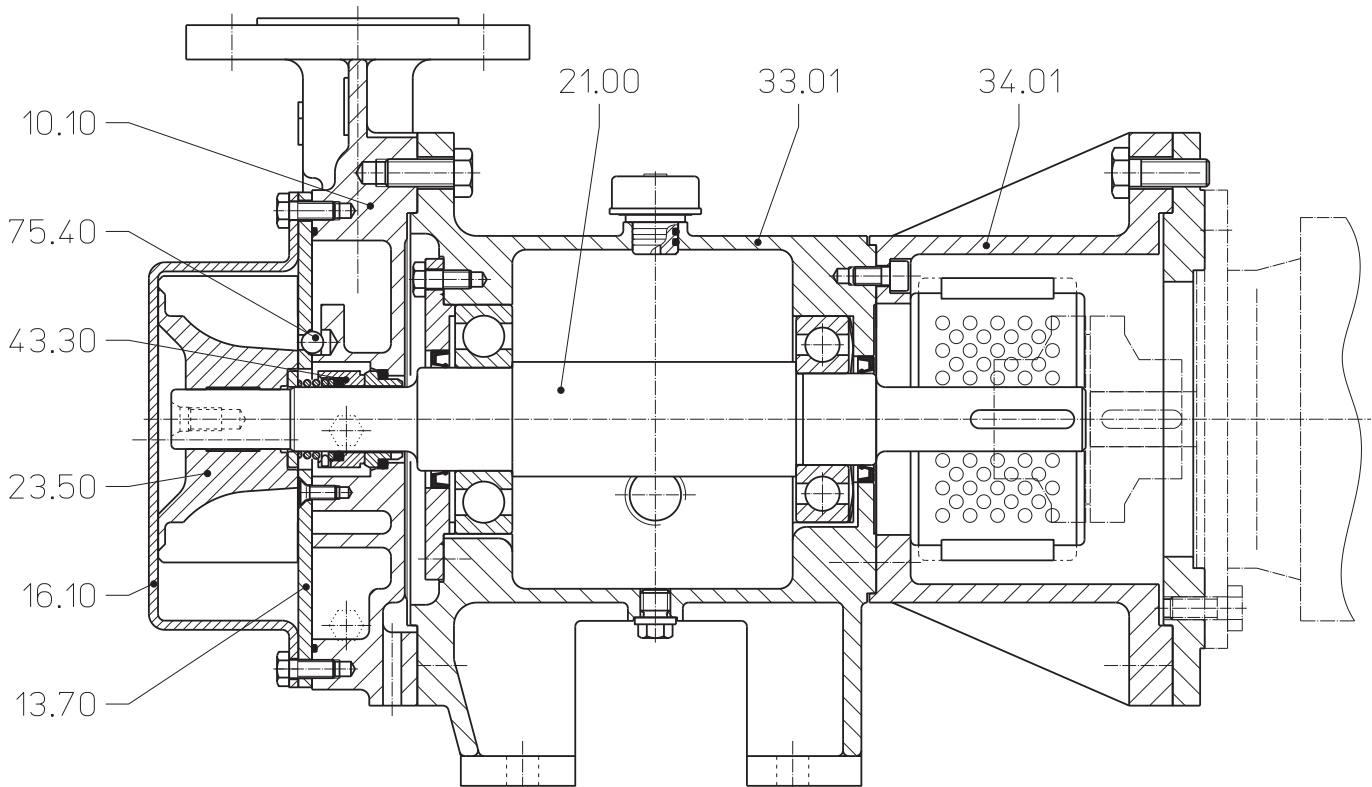

**Make-up Liquid Consumption** in [m³/h] dependent upon suction pressure, speed, drive type and temperature difference.

Suction Pressure in [mbar]		33				120				200				400			
Pump Type	Speed [rpm]	KB			FB	KB			FB	KB			FB	KB			FB
		Temperature Difference [°C]				Temperature Difference [°C]				Temperature Difference [°C]				Temperature Difference [°C]			
		10	5	2		10	5	2		10	5	2		10	5	2	
LEM/LEL 91	2900	0.11	0.19	0.34	0.66	0.13	0.22	0.36	0.62	0.14	0.22	0.36	0.6	0.14	0.22	0.34	0.54
	3500	0.15	0.25	0.40		0.17	0.27	0.40		0.18	0.27	0.40		0.17	0.26	0.38	
LEM/LEL 126	2900	0.15	0.24	0.39	0.66	0.16	0.26	0.40	0.62	0.17	0.27	0.40	0.6	0.17	0.26	0.38	0.54
	3500	0.19	0.29	0.44		0.21	0.31	0.44		0.21	0.31	0.44		0.21	0.31	0.41	
LEM/LEL 161	1460	0.20	0.34	0.61	1.3	0.23	0.39	0.66	1.2	0.25	0.41	0.66	1.14	0.24	0.39	0.60	0.96
	1750	0.26	0.43	0.72		0.30	0.48	0.75		0.31	0.49	0.74		0.31	0.47	0.68	

FB = Total service liquid flow rate on once-through system

KB = Flow of make-up water when combined with partial recirculation liquid at a temperature of 10 °C, 5 °C, 2 °C, warmer than make-up water.

## Performance Characteristics LEM 91 / LEL 91

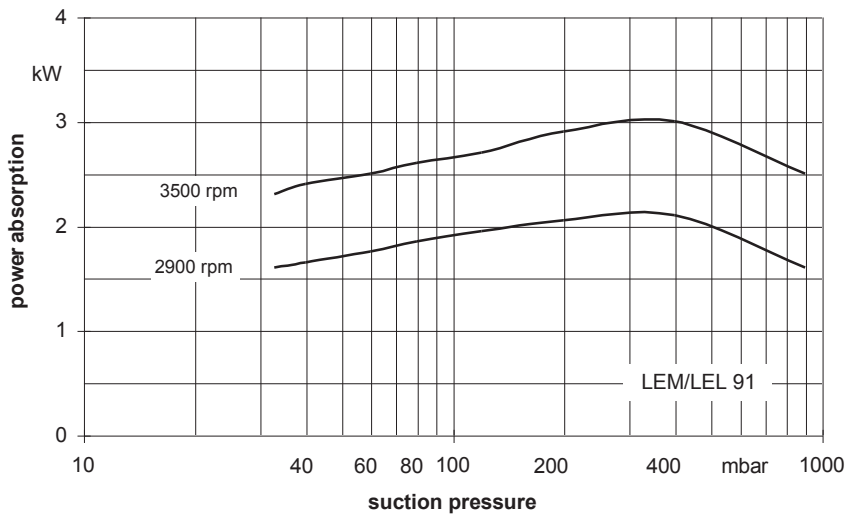
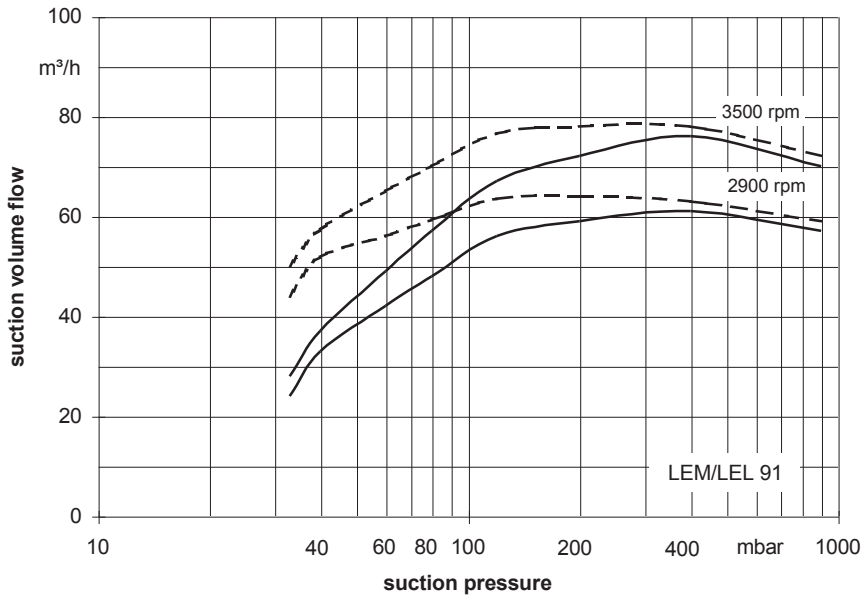

The operating data is valid under the following conditions:

- process media:
  - dry air: 20°C \_\_\_\_\_
  - steam saturated air: 20°C - - - - -
- service liquid:
  - water: 15°C

Pressure of gas to be evacuated: 1013 mbar (atmospheric pressure)

The suction volume is related to the suction pressure.

Tolerance on operating data is 10%.

The maximum consumption of make-up water occurs at the lowest suction pressure.

**Performance Characteristics LEM 126 / LEL 126**

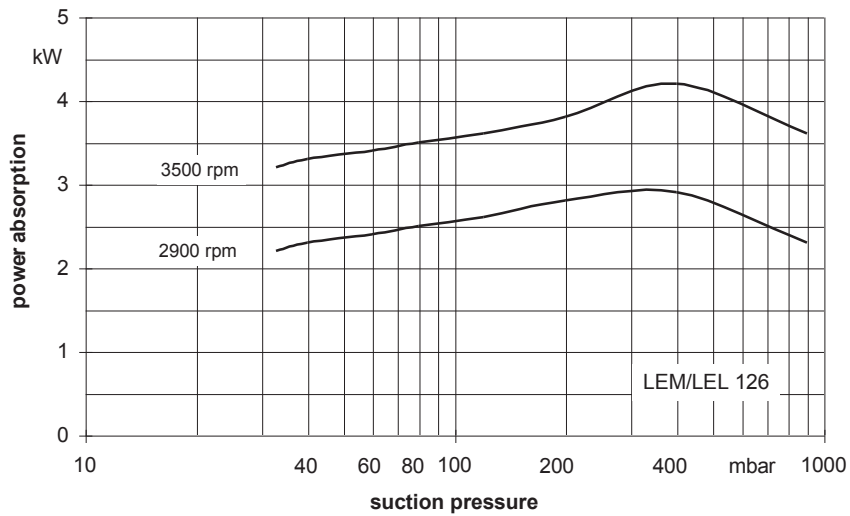
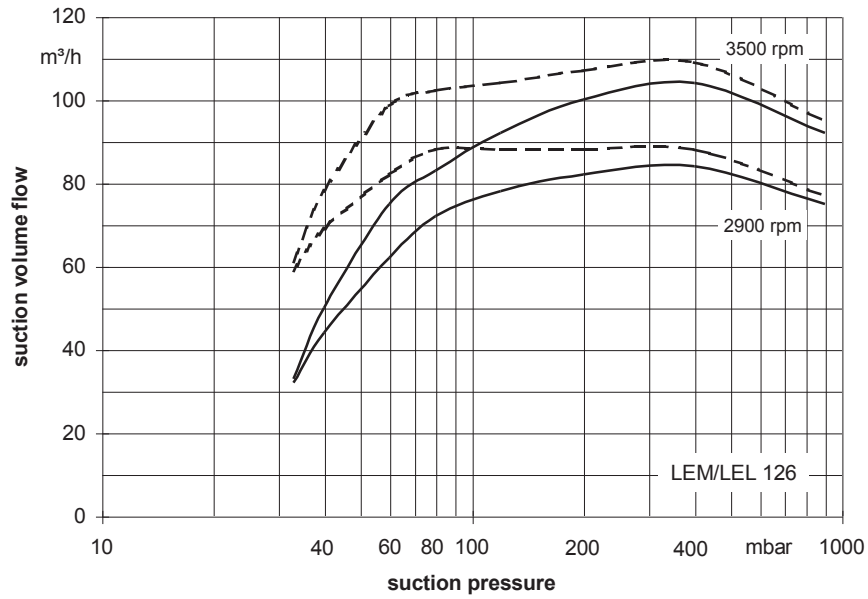

The operating data is valid under the following conditions:

- process media:
  - dry air: 20°C \_\_\_\_\_
  - steam saturated air: 20°C .....
- service liquid:
  - water: 15°C

Pressure of gas to be evacuated: 1013 mbar (atmospheric pressure)

The suction volume is related to the suction pressure.

Tolerance on operating data is 10%.

The maximum consumption of make-up water occurs at the lowest suction pressure.

## Performance Characteristics LEM 161 / LEL 161

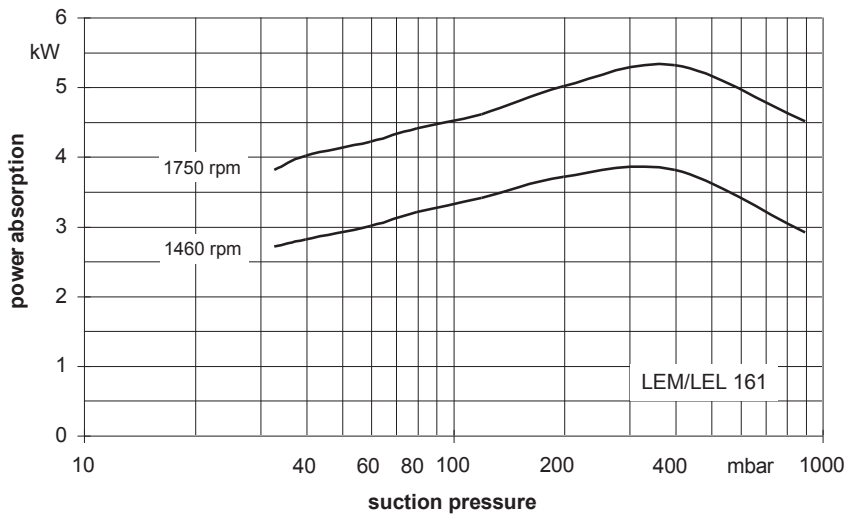
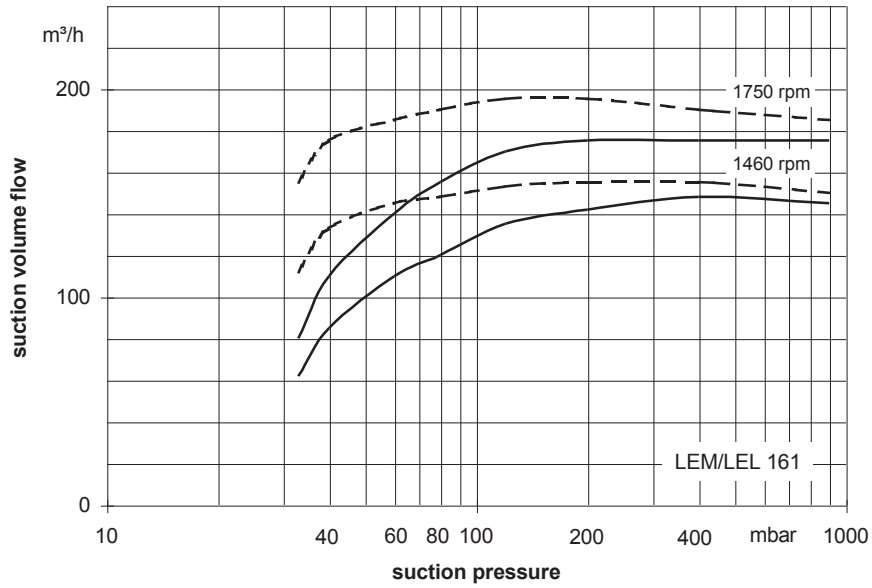

The operating data is valid under the following conditions:

- process media:
  - dry air: 20°C \_\_\_\_\_
  - steam saturated air: 20°C .....
- service liquid:
  - water: 15°C

Pressure of gas to be evacuated: 1013 mbar (atmospheric pressure)

The suction volume is related to the suction pressure.

Tolerance on operating data is 10%.

The maximum consumption of make-up water occurs at the lowest suction pressure.

**Dimensions LEM 91, 126, 161**

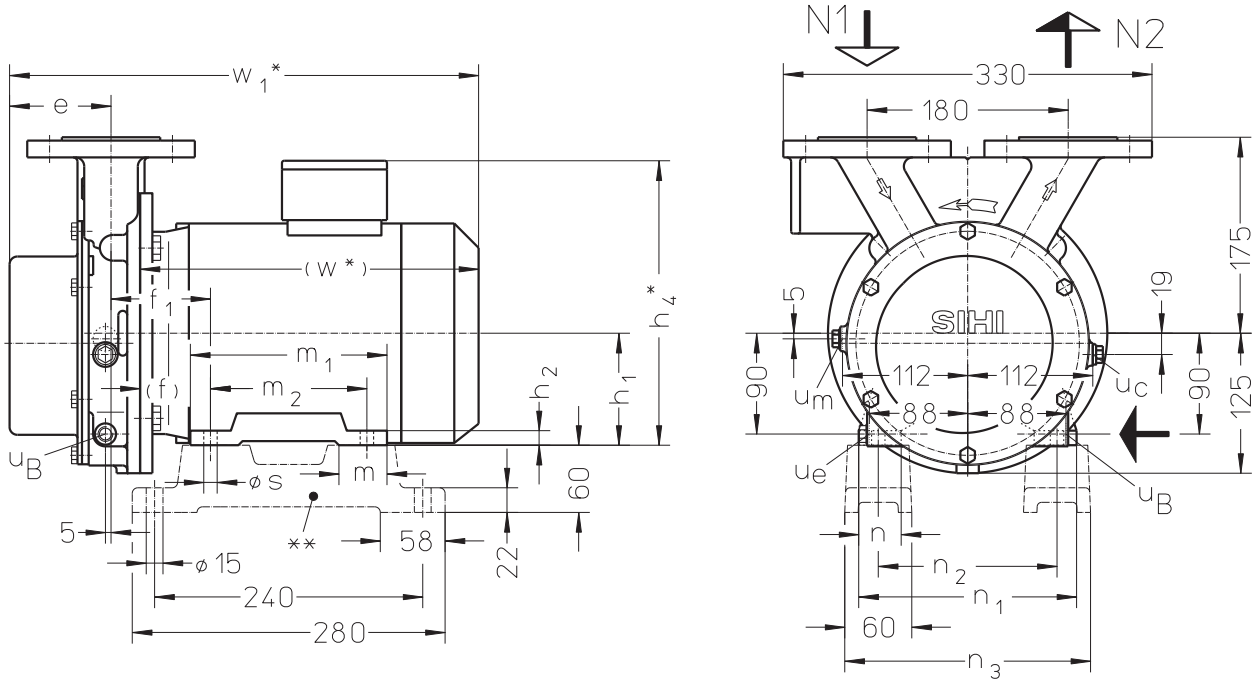

	electric motor IP 55		e [mm]	f [mm]	f <sub>1</sub> [mm]	h <sub>1</sub> [mm]	h <sub>2</sub> [mm]	h <sub>4</sub> * [mm]	m [mm]	m <sub>1</sub> [mm]	m <sub>2</sub> [mm]	n [mm]	n <sub>1</sub> [mm]	n <sub>2</sub> [mm]	n <sub>3</sub> [mm]	s [mm]	w* [mm]	w <sub>1</sub> * [mm]	approx. weight [kg]	
	size	50 Hz kW																		60 Hz kW
LEM 91	90 L	2.2	-	91	56	82	90	11	229	36	155	125	35	170	140	200	9	283	399	34
	100 L	-	3.3		63	89	100	13	256	43	176	140	38	195	160	220	12	303	420	
LEM 126	100 L	3.0	-	95	70	96	112	15	278	45									44	225
	112 M	-	4.8		70	96	112	15	278	45	44	225	190	250	340	461	44			

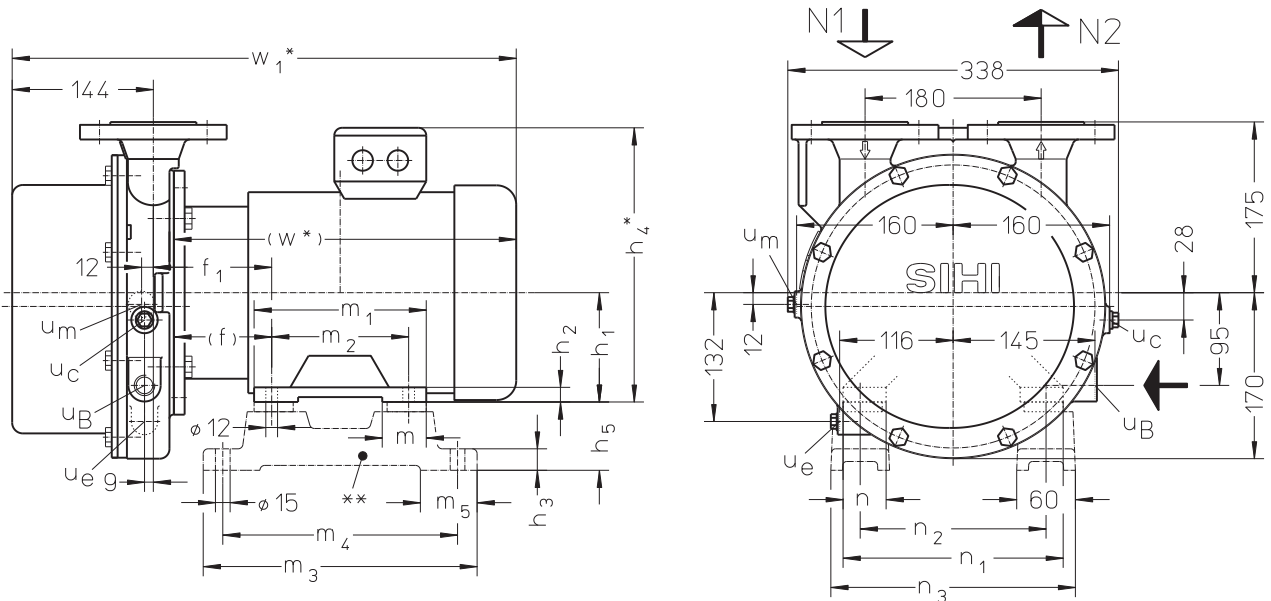

- N 1 = gas inlet DN 40
- N 2 = gas outlet DN 40
- u<sub>B</sub> = connection for service liquid G ¼ (LEM 91/126)  
G ½ (LEM 161)
- u<sub>c</sub> = connection for cavitation protection G ¼
- u<sub>e</sub> = connection for drain G ¼
- u<sub>m</sub> = connection for pressure gauge G ¼

	electric motor IP 55		f [mm]	f <sub>1</sub> [mm]	h <sub>1</sub> [mm]	h <sub>2</sub> [mm]	h <sub>4</sub> * [mm]	h <sub>5</sub> [mm]	m [mm]	m <sub>1</sub> [mm]	m <sub>2</sub> [mm]	m <sub>3</sub> [mm]	m <sub>4</sub> [mm]	m <sub>5</sub> [mm]	n [mm]	n <sub>1</sub> [mm]	n <sub>2</sub> [mm]	n <sub>3</sub> [mm]	w* [mm]	w <sub>1</sub> * [mm]	approx. weight [kg]	
	size	50 Hz kW																				60 Hz kW
LEM 161	112 M	4.0	-	100	121	112	15	281	70	45	176	140	280	240	58	44	225	190	250	390	555	68
	132 M	-	6.0	110	131	132	18	320	60	88	218	178	320	278	-	55	256	216	276	426	591	

other motors on request  
 \* dimensions dependent upon motor supplier  
 \*\* see list of accessories  
 flange connections see page 11

## Dimensions LEL 91, 126, 161

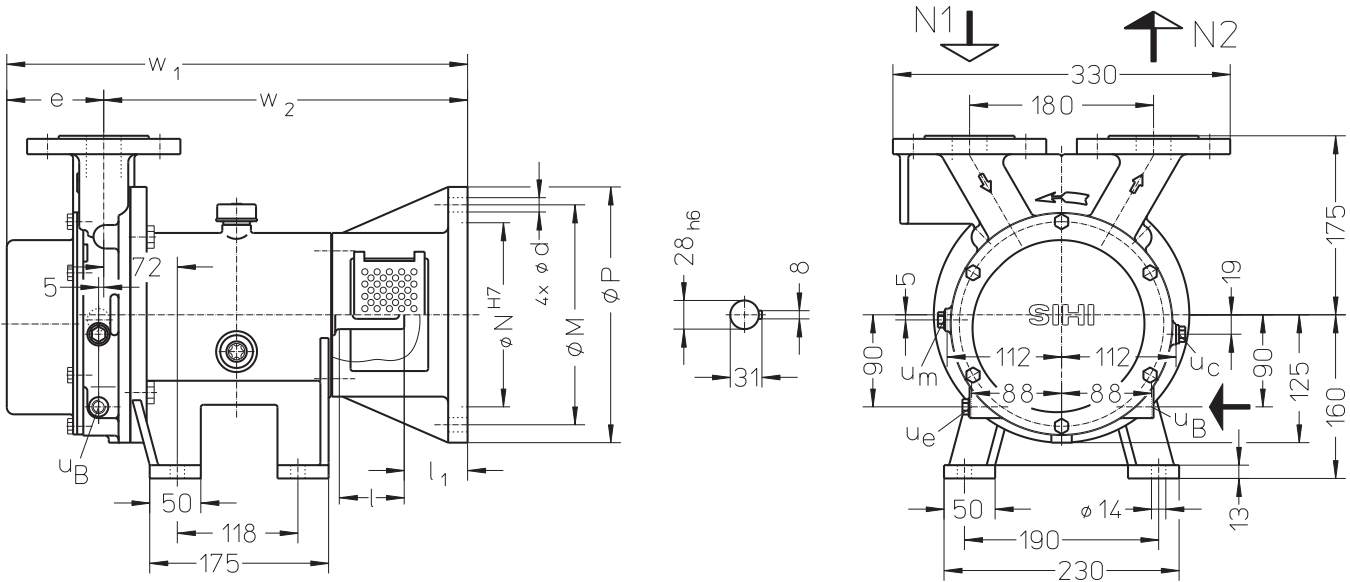

	electric motor 50 Hz		d [mm]	e [mm]	l [mm]	l <sub>1</sub> [mm]	M [mm]	N [mm]	P [mm]	w <sub>1</sub> [mm]	w <sub>2</sub> [mm]	approx. weight [kg]	
	size	IP 55 kW											EEx e II T3
LEL 91	90 L	2.2	-	M10	91	87.5	52	165	130	200	461	370	53
	100 L	-	2.5	14							446		
LEL 126	100 L	3.0	-	14	95	63.5	62	215	180	250	451	356	49
	112 M	-	3.3										

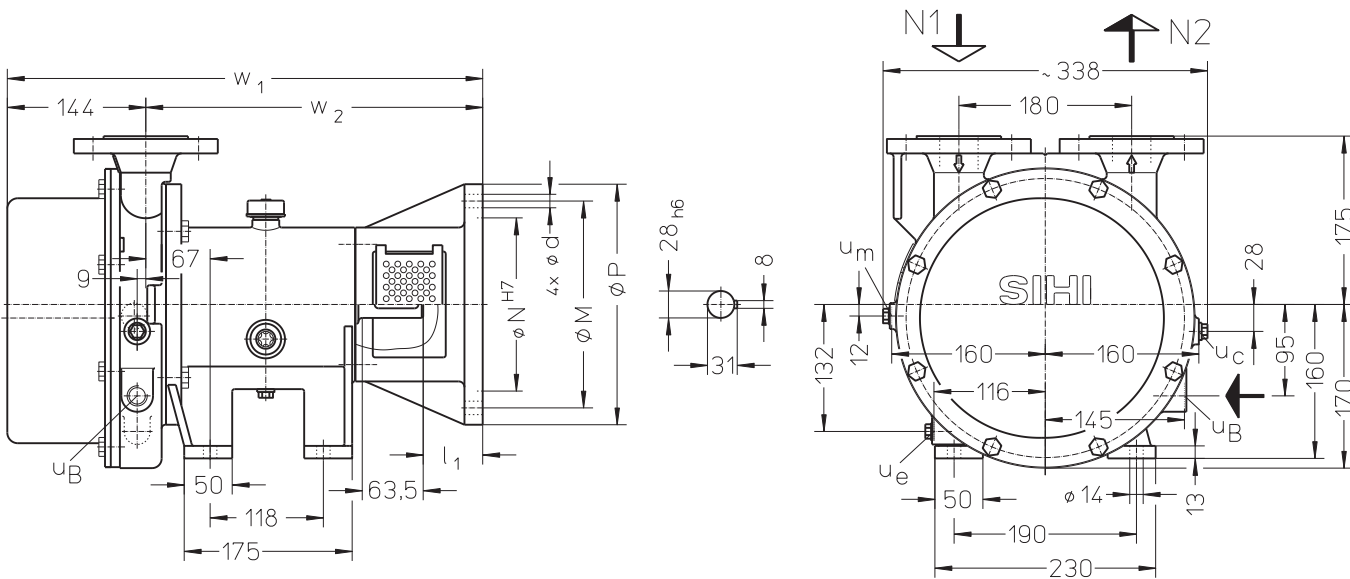

N 1 = gas inlet DN 40

N 2 = gas outlet DN 40

u<sub>B</sub> = connection for service liquid G ¼ (LEL 91/126)  
G ½ (LEL 161)

u<sub>c</sub> = connection for cavitation protection G ¼

u<sub>e</sub> = connection for drain G ¼

u<sub>m</sub> = connection for pressure gauge G ¼

	electric motor 50 Hz		d [mm]	l <sub>1</sub> [mm]	M [mm]	N [mm]	P [mm]	w <sub>1</sub> [mm]	w <sub>2</sub> [mm]	approx. weight [kg]	
	size	IP 55 kW									EEx e II T3
LEL 161	112 M	4.0	-	14	62	215	180	250	495	351	71
	132 S	-	5.0	M12	82	265	230	300	515	371	78

other motors on request

flange connections see page 11



Arrangement drawing LEM 91, 126, 161

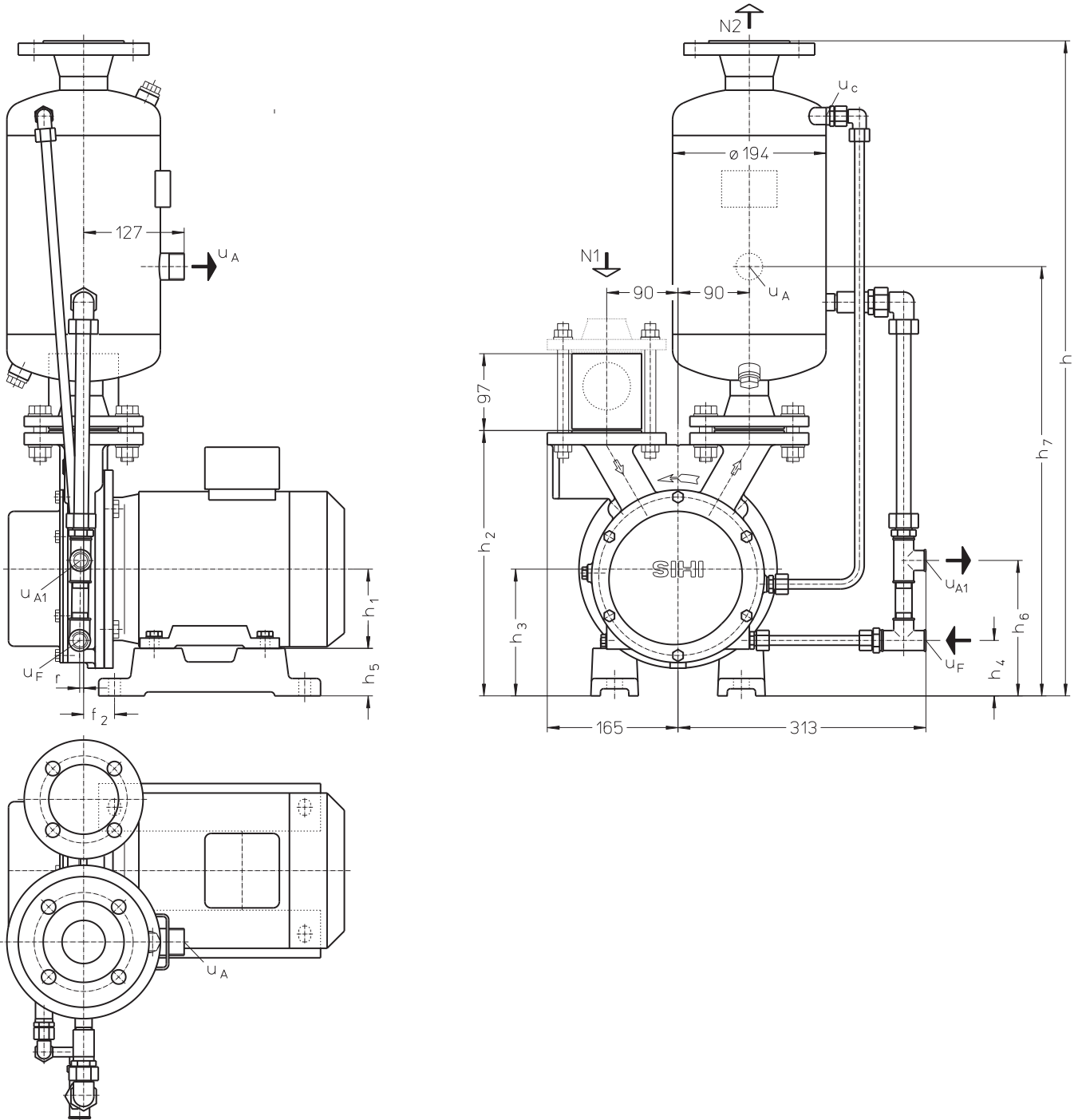

N 1 = gas inlet DN 40

N 2 = gas outlet DN 50

u<sub>c</sub> = connection for cavitation protection G 3/8

u<sub>A</sub> = liquid drain G 1

u<sub>A1</sub> = liquid drain G 1/2

u<sub>F</sub> = connection for make-up liquid G 1/2

	electric motor IP 55			f <sub>2</sub> [mm]	h [mm]	h <sub>1</sub> [mm]	h <sub>2</sub> [mm]	h <sub>3</sub> [mm]	h <sub>4</sub> [mm]	h <sub>5</sub> [mm]	h <sub>6</sub> [mm]	h <sub>7</sub> [mm]	r [mm]	approx. weight [kg]
	size	50 Hz	60 Hz											
LEM 91	90 L	2.2	-	25	817	90	325	150	60	60	161	532	5	46
	100 L	-	3.3											
LEM 126	100 L	3.0	-	39	827	100	335	160	70	60	171	542	5	51
	112 M	-	4.8											
LEM 161	112 M	4.0	-	71	849	112	357	182	87	70	193	564	9	82
	132 M	-	6.0											

other motors on request

flange connections see page 11

Arrangement drawing LEM 91, 126, 161 with thermostatic control

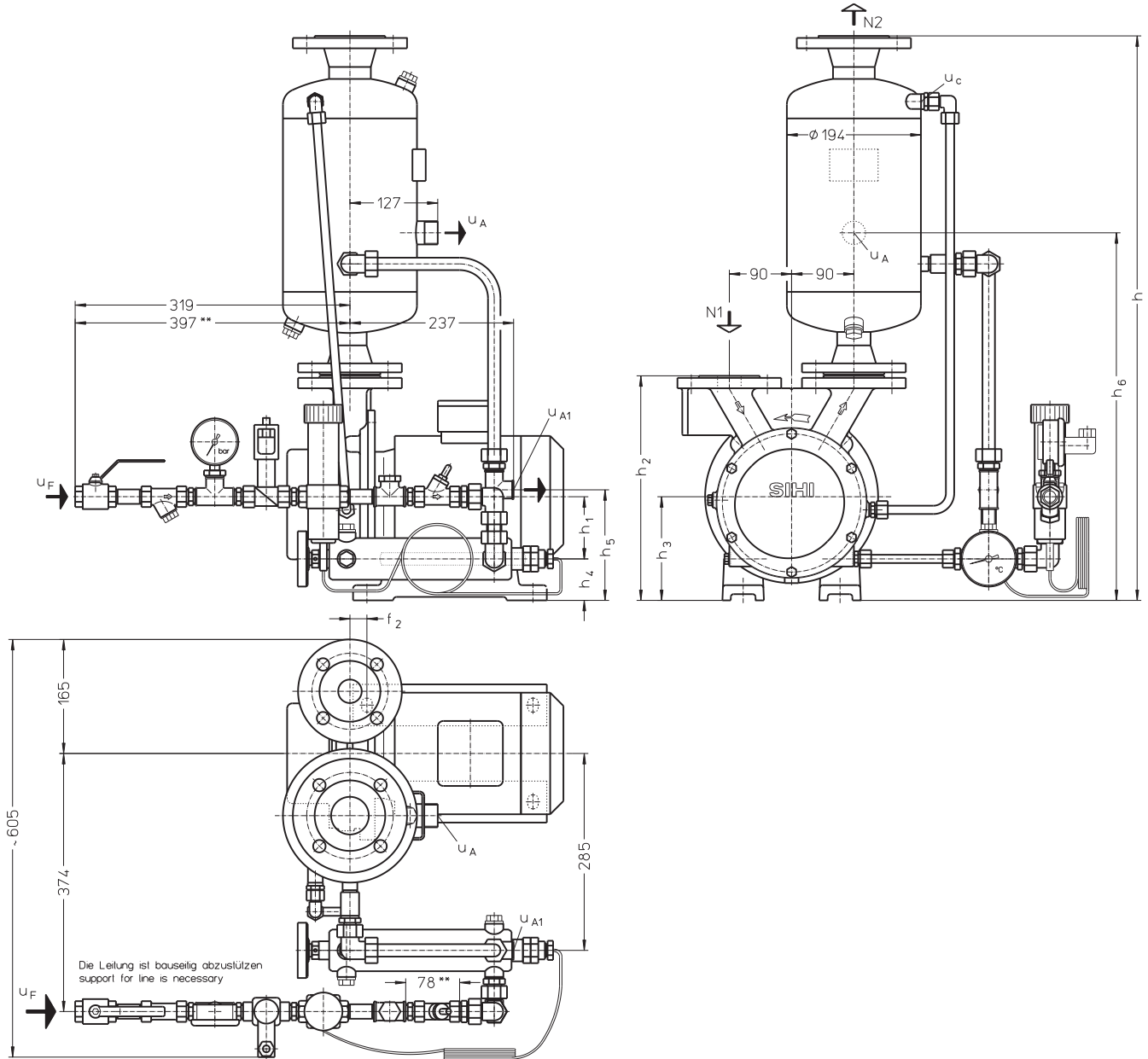

- N 1 = gas inlet DN 40
- N 2 = gas outlet DN 50
- U<sub>A</sub> = liquid drain G 1
- U<sub>A1</sub> = liquid drain G 1/2
- U<sub>c</sub> = connection for cavitation protection G 3/8
- U<sub>F</sub> = connection for make-up liquid G 1/2

	electric motor IP 55		f <sub>2</sub> [mm]	h [mm]	h <sub>1</sub> [mm]	h <sub>2</sub> [mm]	h <sub>3</sub> [mm]	h <sub>4</sub> [mm]	h <sub>5</sub> [mm]	h <sub>6</sub> [mm]	approx. weight [kg]	
	size	kW										
		50 Hz	60 Hz									
LEM 91	90 L	2.2	-	25	817	90	325	150	60	160	532	51
	100 L	-	3.3	39	827	100	335	160		170	542	56
LEM 126	100 L	3.0	-	46	839	112	347	172	70	192	564	87
	112 M	-	4.8				357	182				
LEM 161	112 M	4.0	-	71	849	132	367	192	60	202	574	115
	132 M	-	6.0	81	859	132	367	192	60	202	574	115

other motors on request

\*\* only at material 1.4571 the line

flange connections see page 11

Arrangement drawing LEL 91, 126, 161

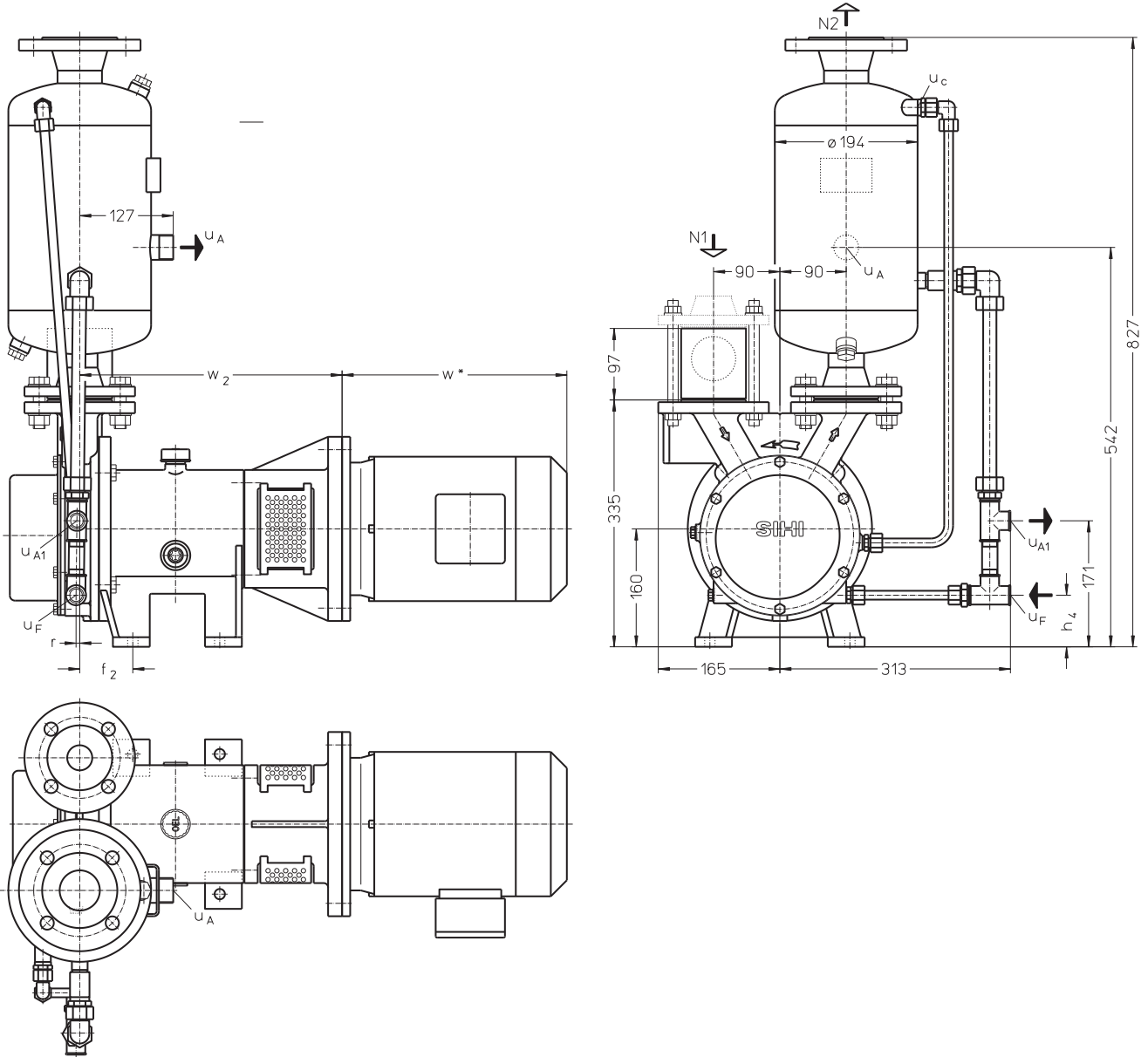

N 1 = gas inlet DN 40

N 2 = gas outlet DN 50

u<sub>c</sub> = connection for cavitation protection G 3/8

u<sub>A</sub> = liquid drain G 1

u<sub>A1</sub> = liquid drain G 1/2

u<sub>F</sub> = connection for make-up liquid G 1/2

	electric motor 50 Hz		f <sub>2</sub> [mm]	h <sub>4</sub> [mm]	r [mm]	w* [mm]	w <sub>2</sub> [mm]	approx. weight [kg]			
	size	kW									
LEL 91	90 L	2.2	72	70	5	269	370	82			
	100 L	-							2.5	303	356
LEL 126	100 L	3.0				67	65	9	320		
	112 M	-								3.3	405
LEL 161	112 M	4.0						114			
	132 M	-	5.0					158			

flange connections according to DIN 2501 PN 10 [mm]		
DN	40	50
k	110	125
D	150	165
number x d <sub>2</sub>	4 x 18	4 x 18

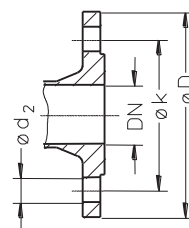

other motors on request

\* dimension dependent upon motor supplier

## Data regarding the pump size - order notes

range + size	hydraulic + bearings	shaft seal	materials	casing sealing	*code of motor connection*
	<ul style="list-style-type: none"> <li>C• hydraulic A,</li> <li>9• with flange connection</li> <li>•Z two grease lubricated antifriction bearings arranged in the motor</li> <li>•B similar to •Z, but arranged in the motor carrier</li> </ul>	B3N mechanical seal, o-rings Viton	OK main parts out of cast iron, impeller in low alloyed steel	7 o-rings, Teflon cord	ES for IMB5 motor 90L flange ø200 FS for IMB5 motor 100L resp. 112M flange ø250 GS for IMB5 motor 132S flange ø300
LEM	91 CZ	B3N	OK	0	ES, FS
	126 CZ				
	161 9Z				
LEL	91 CB	B3N	OK	0	FS
	126 CB				
	161 9B				
					FS, GS

\* = only LEL

### Motor selection

For our products we offer a lot of different motor types.  
To identify the right motor please specify frequency, voltage and protection class.

#### Example for ordering LEM:

LEM 126 CZ B3N OK 7 with 3.0 kW AC motor 50 Hz, 230 V $\Delta$ , IP55

#### Example for ordering LEL:

LEL 161 9B B3N OK 7 for 4.0 kW AC motor 50 Hz, 230 V $\Delta$ , IP55 (motor size 112) has the complete designation:

LEL 161 9B B3N OK 7 FS

**Accessories LEM 91, 126, 161; LEL 91, 126, 161 with flange connection**

Recommended Accessory	Material Execution		LEM 91 LEL 91	LEM 126 LEL 126	LEM 161 LEL 161
<b>Top Mounted Liquid Separator</b>		Type / weight	XBa 1042 / 9.7 kg		
Top mounted separator	Steel, galvanised	SIHI-Part No.	35 000 396		
Service liquid pipework, standard execution	Steel, galvanised	SIHI-Part No.	20 055 588		20 055 587
Service liquid pipework, thermostatic control 24V	1.0254 + Brass	SIHI-Part No.	20 048 239		20 048 241
Cavitation protection pipework	Steel, galvanised	SIHI-Part No.	20 055 586		20 055 585
<b>Side Mounted Liquid Separator</b>		Type / weight	XBp 0413 / 28 kg		
Side mounted separator	Steel, galvanised	SIHI-Part No.	35 000 502		
Pressure pipework (bend)	1.0254	SIHI-Part No.	35 003 172		
service liquid pipework, standard execution	1.0254	SIHI-Part No.	35 012 172		20 061 807
Cavitation protection pipework	1.0254	SIHI-Part No.	20 045 648		20 045 647
<b>Sterling SIHI – Gas Ejector</b> see Technical Catalogue – Gas Ejector					
at service liquid temperature 15 °C		Type weight	GEV 91 E 7 kg	GEV 90 A 9 kg	GEV 150 A 12 kg
at service liquid temperature 30 °C		Type weight	GEV 91 F 7 kg	GEV 90 B 9 kg	GEV 150 B 12 kg
<b>Sterling SIHI – Non Return Ball Valve</b>					
Intermediate flange execution XCK 40	0.6025 + butadiene rubber 0.6025 + Teflon	SIHI-Part No. weight	20 072 746 / 2.8 kg 20 072 745 / 2.8 kg		
Flange execution with glass cylinder XCK 406	0.6025 + butadiene rubber 0.6025 + Teflon	SIHI-Part No. weight	20 072 835 / 7.0 kg 20 072 836 / 7.0 kg		
<b>Support foot</b> only for LEM					
for motor size 90 L		SIHI-Part No.	20 047 009	-	-
for motor size 100 L, 112 M			20 047 010	20 047 010	20 047 011
for motor size 132 M			-	-	20 047 012
<b>Motor</b> standard execution IP 55		Size Power Weight	90 L 2.2 kW 15 kg	100 L 3.0 kW 20 kg	112 M 4.0 kW 28 kg
Coupling for motor IP 55 pump side motor side		Type / weight SIHI-Part No.	B 68 / 1.5 kg 43 028 149 43 021 405	B 80 / 1.5 kg 43 021 414 43 021 417	
<b>Motor</b> in EEx e II T3 execution		Size Power Weight	100 L 2.5 kW 22 kg	112 M 3.3 kW 28 kg	132 S 5.0 kW 65 kg
Coupling for motor EEx e II T3 pump side motor side		Type / weight SIHI-Part No.	BDS 88 / 1.9 kg 43 111 058 43 111 029		BDS 103 / 3.1 kg 43 111 051 43 111 040

Designs subject to change without prior notice.

**Sterling SIHI GmbH**

 Lindenstraße 170, D-25524 Itzehoe, Germany  
 Telephone +49 (0)48 21 / 7 71 - 01, Fax +49 (0)48 21 / 7 71-274  
 www.sihi.com