

# Liquid ring vacuum pumps

in compact design



## LEM 91, LEM 126, LEM 161 LEL 91, LEL 126, LEL 161 with threaded connection

**Pressure range:** 33 to 1013 mbar  
**Suction volume flow:** 24 to 195 m<sup>3</sup>/h

### CONSTRUCTION

SIHI liquid ring vacuum pumps are displacement pumps of uncomplicated and robust construction with the following particular features:

- non-polluting due to nearly isothermal compression
- oil-free, as no lubrication in the working chamber
- handling of nearly all gases and vapours
- small quantities of entrained liquid can be handled
- easy maintenance and reliable operation
- low noise and nearly free from vibration
- wide choice of material, therefore applicable nearly everywhere
- protection against cavitation as standard
- incorporated dirt drain
- incorporated central drain
- no metallic contact of the rotating parts

The SIHI liquid ring vacuum pumps LEM/LEL are single-stage ones.

### APPLICATION

Handling and exhausting of dry and humid gases; entrained liquid can be handled during normal duty. The pumps are applied in all fields where a pressure of 33 to 900 mbar must be created by robust vacuum pumps.



### NOTE

During operation the pump must continuously be supplied with service liquid, normally water, in order to eliminate the heat resulting from the gas compression and to replenish the liquid ring, because part of the liquid is leaving the pump together with the gas. This liquid can be separated from the gas in a liquid separator (see catalogue part accessories).

It is possible to reuse the service liquid. The pumps are equipped with a device by which the contaminated service liquid can continuously be drained during operation (dirt drain), if necessary.

The direction of rotation is clockwise, when looking from the drive on the pump.

### GENERAL TECHNICAL DATA

Pump type	unit	LEM 91 LEL 91	LEM 126 LEL 126	LEM 161 LEL 161
Speed	50 Hz rpm 60 Hz rpm	2900 3500		1450 1750
Maximum overpressure on compression	bar	LEM 0.3 / LEL 0.5		
Permissible pressure difference between suction and discharge side	max. min. bar	LEM 1.1 / LEL 1.3 0.2		
Hydraulic test pressure (overpressure)	bar	3		
Moment of inertia of rotating parts of pump and water content	kg · m <sup>2</sup>	0.007	0.009	0.070
Noise level at 80 mbar suction pressure	dB (A)	72 (67)*		65
Maximum gas temperature	dry saturated °C °C	200 100		
Service liquid	°C	80		
Maximum permissible temperature		10		
Minimum permissible temperature		4		
Maximum viscosity	mm <sup>2</sup> /s	1200		
Maximum density	kg/m <sup>3</sup>	0.5		
Liquid capacity up to middle of shaft	litre	0.5	0.6	2.0
Maximum flow resistance of the heat exchanger	bar	0.2		

The combination of several limiting values is not admissible.

\* Value in parenthesis for measuring with sound insulation cup

## Materials

Item	COMPONENTS	MATERIALS	
		0K	4B
10.10	Vacuum casing	0.6025	1.4408
13.70	Guide disc	1.4301	1.4404
16.10	Cover		
21.00 *	Shaft	1.4571	
23.50	Vane wheel impeller	1.4308	1.4408
33.01 *	Bearing bracket	0.6025	0.6025 (stove enamelling)
34.01 *	Motor carrier		
43.30	Mechanical seal	Cr-steel / carbon / butadiene rubber	Cr Ni Mo-steel / carbon / Viton
75.40	Valve balls	Polyamide A	PTFE

\* only for LEL 91, 126, 161

## Cut-away diagram LEM 91, 126, 161

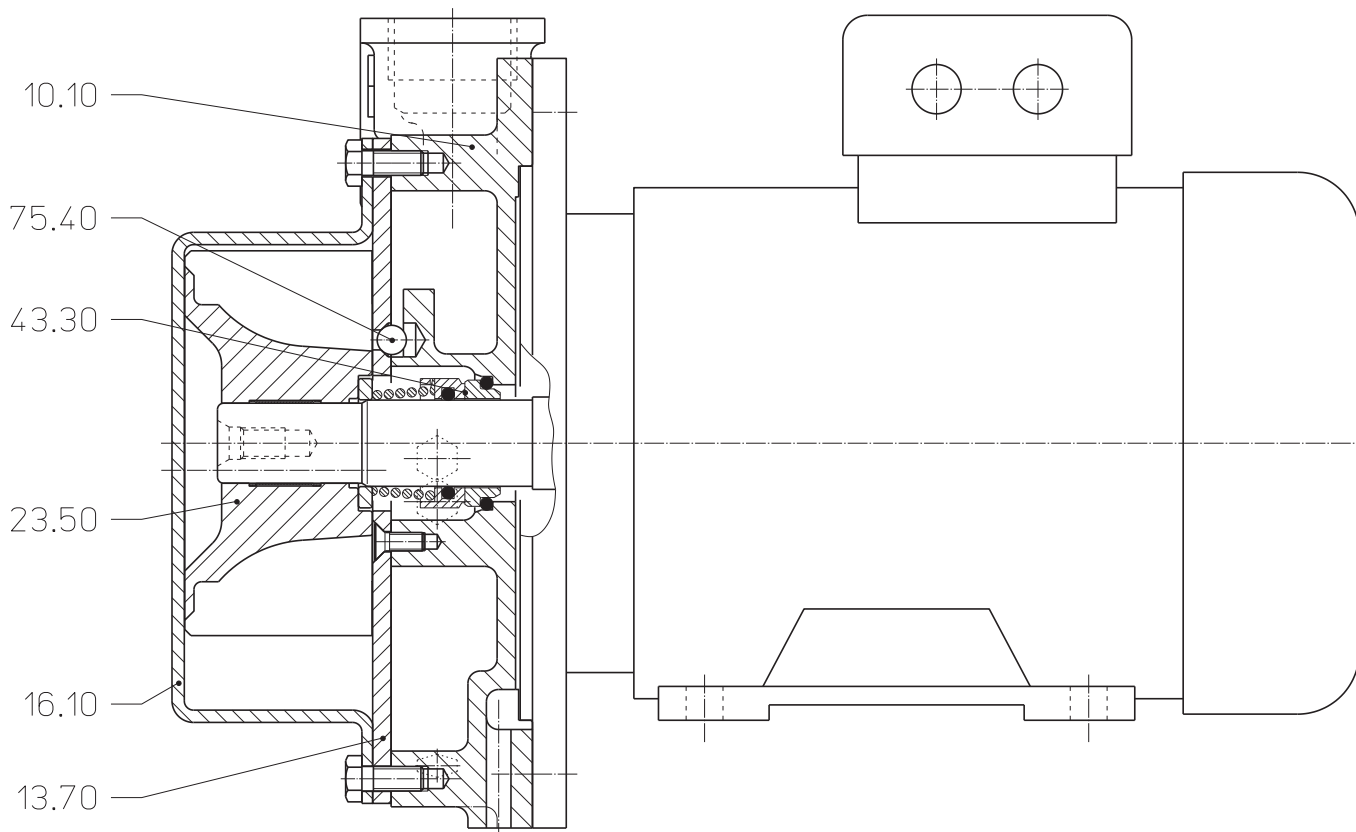

**Cut-away diagram LEL 91, 126, 161**

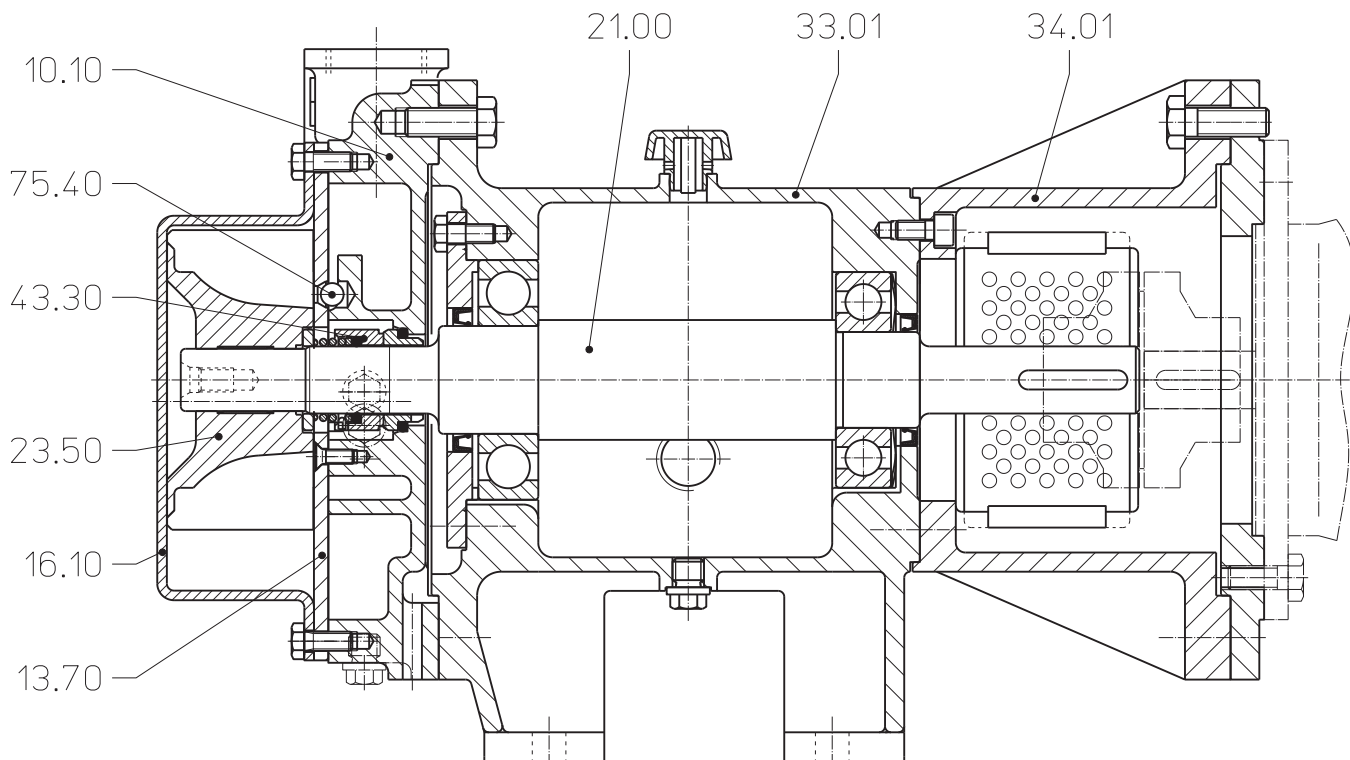

**Make-up Liquid Consumption** in [m³/h] dependent upon suction pressure, speed, drive type and temperature difference.

suction pressure in [mbar]		33			120			200			400						
Pump type	speed [rpm]	KB			FB	KB			FB	KB			FB				
		temperature difference [°C]				temperature difference [°C]				temperature difference [°C]							
		10	5	2		10	5	2		10	5	2		10	5	2	
LEM/LEL 91	2900	0.11	0.19	0.34	0.66	0.13	0.22	0.36	0.62	0.14	0.22	0.36	0.6	0.14	0.22	0.34	0.54
	3500	0.15	0.25	0.40		0.17	0.27	0.40		0.18	0.27	0.40		0.17	0.26	0.38	
LEM/LEL 126	2900	0.15	0.24	0.39	0.66	0.16	0.26	0.40	0.62	0.17	0.27	0.40	0.6	0.17	0.26	0.38	0.54
	3500	0.19	0.29	0.44		0.21	0.31	0.44		0.21	0.31	0.44		0.21	0.31	0.41	
LEM/LEL 161	1460	0.20	0.34	0.61	1.3	0.23	0.39	0.66	1.2	0.25	0.41	0.66	1.14	0.24	0.39	0.60	0.96
	1750	0.26	0.43	0.72		0.30	0.48	0.75		0.31	0.49	0.74		0.31	0.47	0.68	

FB = total service liquid flow rate on once-through system

KB = flow of make-up water when combined with partial recirculation liquid at a temperature of 10 °C, 5 °C, 2 °C, warmer than make-up water.

## Performance Characteristics LEM 91 / LEL 91

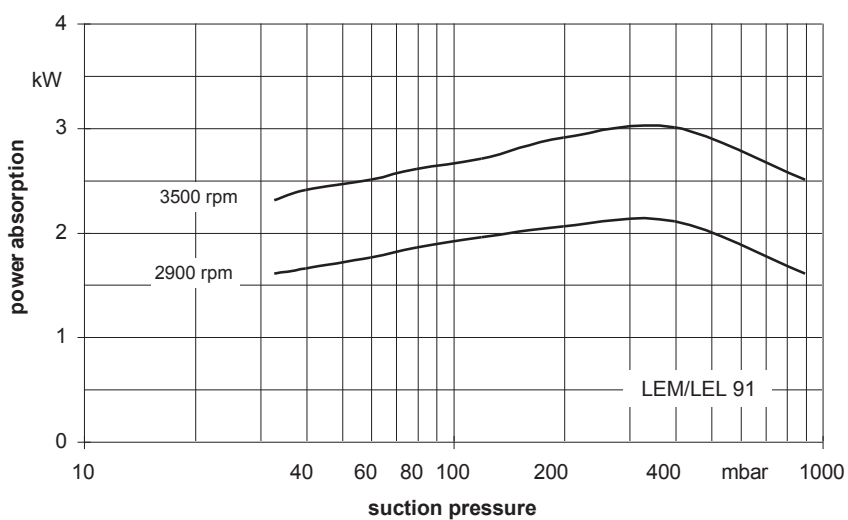
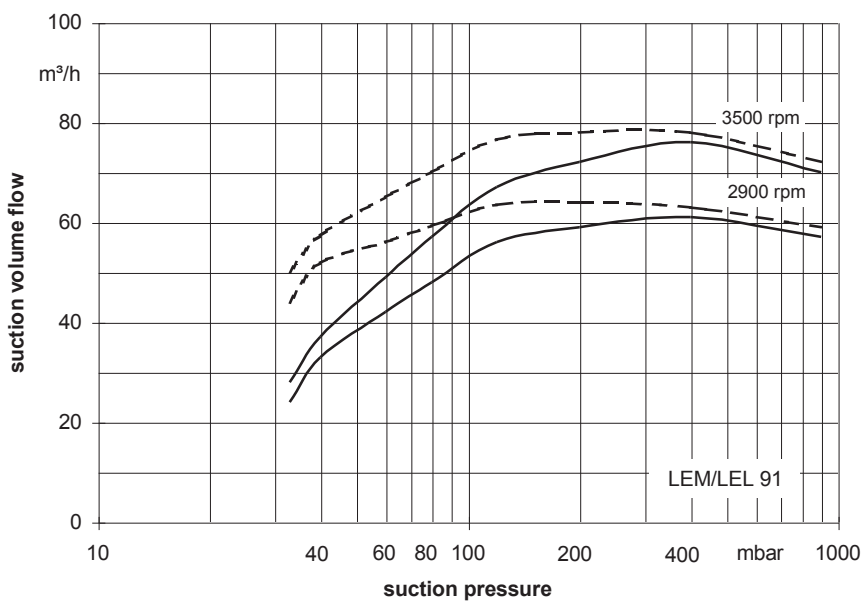

The operating data is valid under the following conditions:

- process media:
  - dry air: 20°C —————
  - steam saturated air: 20°C - - - - -
- service liquid:
  - water: 15°C

Pressure of gas to be evacuated: 1013 mbar (atmospheric pressure)

The suction volume is related to the suction pressure.

Tolerance on operating data is 10%.

The maximum consumption of make-up water occurs at the lowest suction pressure.

**Performance Characteristics LEM 126 / LEL 126**

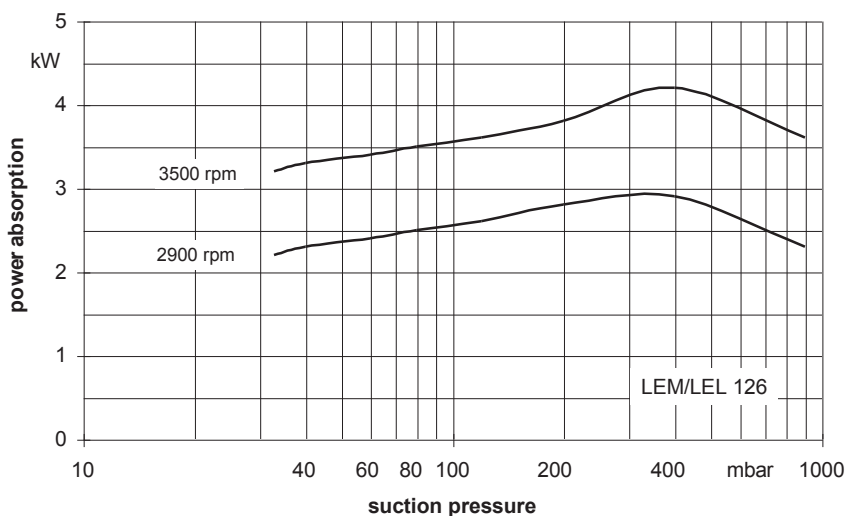
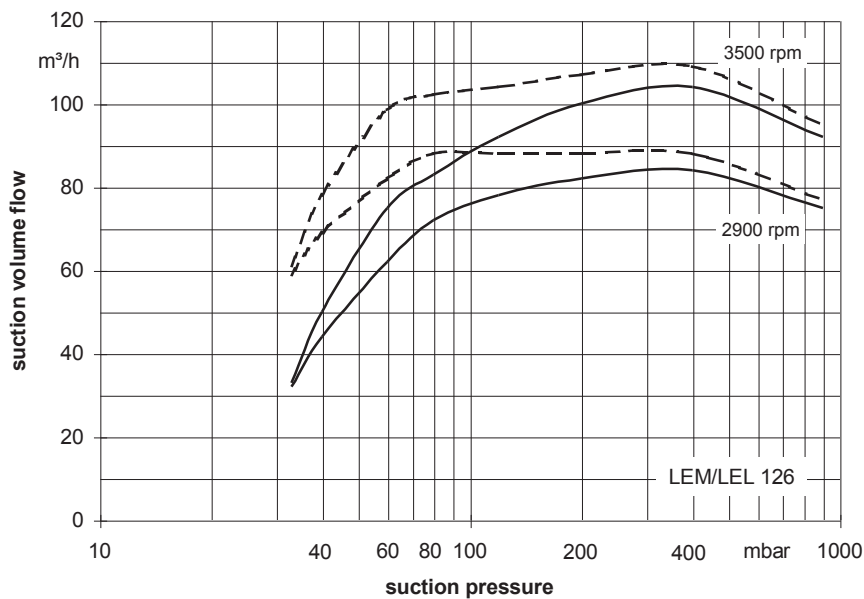

The operating data is valid under the following conditions:

- process media:
  - dry air: 20°C —————
  - steam saturated air: 20°C - - - - -
- service liquid:
  - water: 15°C

Pressure of gas to be evacuated: 1013 mbar (atmospheric pressure)

The suction volume is related to the suction pressure.

Tolerance on operating data is 10%.

The maximum consumption of make-up water occurs at the lowest suction pressure.

**Performance Characteristics LEM 161 / LEL 161**

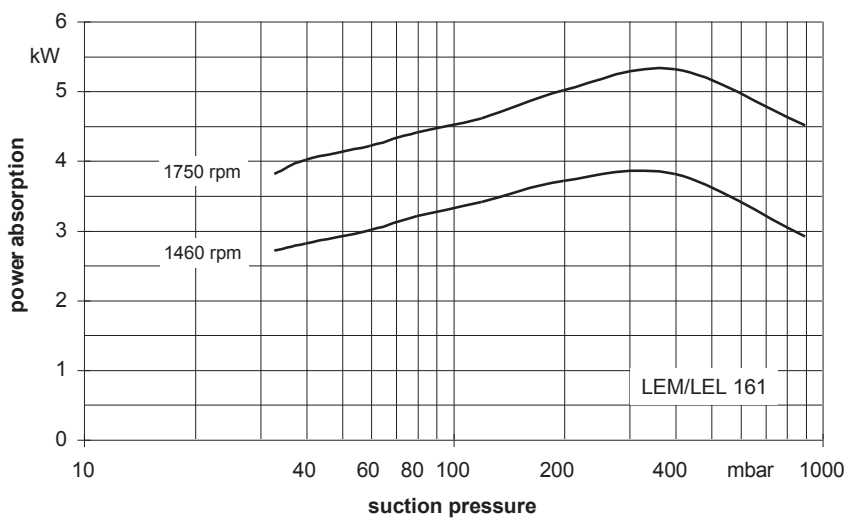
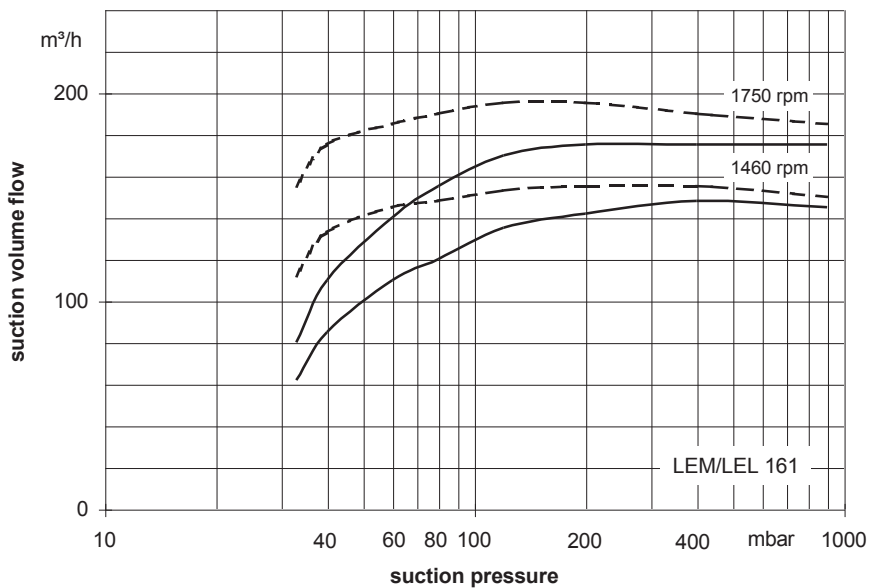

The operating data is valid under the following conditions:

- process media:
  - dry air: 20°C \_\_\_\_\_
  - steam saturated air: 20°C - - - - -
- service liquid:
  - water: 15°C

Pressure of gas to be evacuated: 1013 mbar (atmospheric pressure)

The suction volume is related to the suction pressure.

Tolerance on operating data is 10%.

The maximum consumption of make-up water occurs at the lowest suction pressure.

**Dimensions LEM 91, 126, 161**

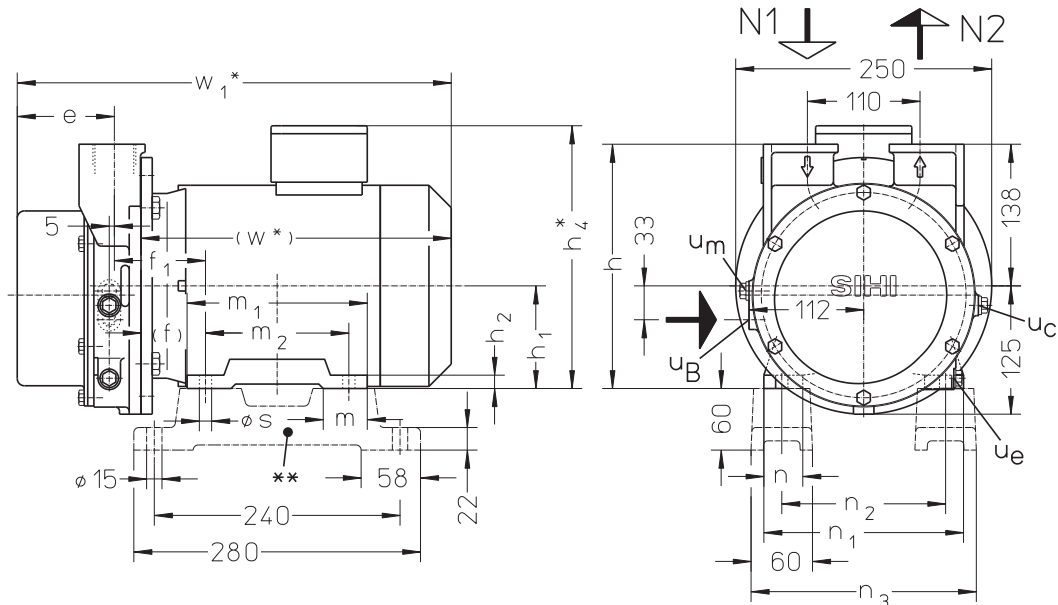

N 1 = gas inlet G 1¼

N 2 = gas outlet G 1¼

u<sub>B</sub> = connection for service liquid G ¼

u<sub>c</sub> = connection for cavitation protection G ¼

u<sub>e</sub> = connection for drain G ¼

u<sub>m</sub> = connection for pressure gauge G ¼

	electric motor IP 55		e [mm]	f [mm]	f <sub>1</sub> [mm]	h [mm]	h <sub>1</sub> [mm]	h <sub>2</sub> [mm]	h <sub>4</sub> * [mm]	m [mm]	m <sub>1</sub> [mm]	m <sub>2</sub> [mm]	n [mm]	n <sub>1</sub> [mm]	n <sub>2</sub> [mm]	n <sub>3</sub> [mm]	s [mm]	w* [mm]	w <sub>1</sub> * [mm]	approx. weight [kg]	
	size	50 Hz kW																			60 Hz kW
LEM 91	90 L	2.2	-	91	56	82	228	90	11	229	36	155	125	35	170	140	200	9	283	399	29
	100 L	-	3.3		63	89	238	100	13	253	43	176	140	38	195	160	220	12	303	420	34
LEM 126	100 L	3.0	-	95	70	96	250	112	15	278	45									44	
	112 M	-	4.8		340	461	39														

other motors on request

\* dimensions dependent upon motor supplier

\*\* see list of accessories

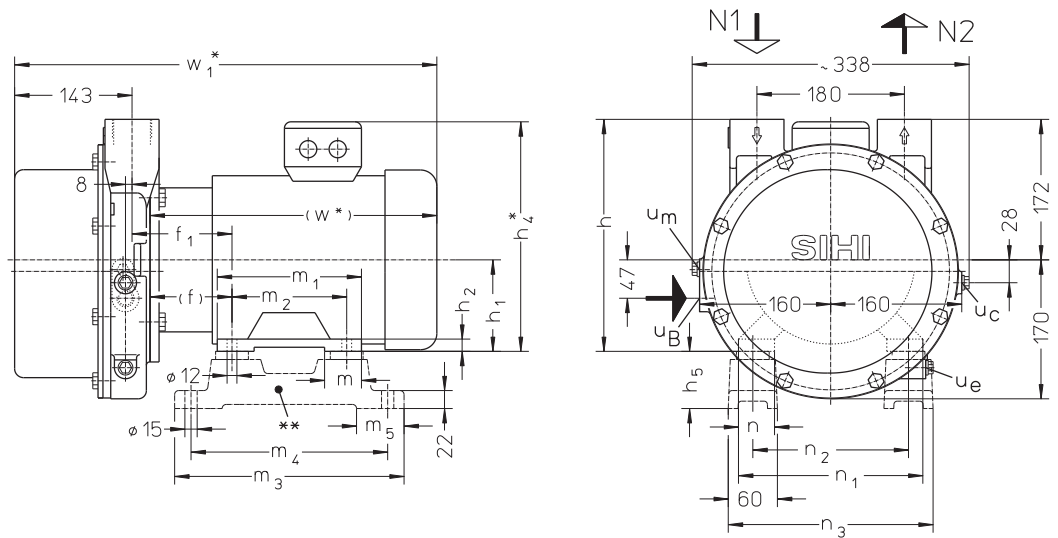

N 1 = gas inlet G 1½

N 2 = gas outlet G 1½

u<sub>B</sub> = connection for service liquid G ½

u<sub>c</sub> = connection for cavitation protection G ¼

u<sub>e</sub> = connection for drain G ¼

u<sub>m</sub> = connection for pressure gauge G ¼

	electric motor IP 55		f [mm]	f <sub>1</sub> [mm]	h [mm]	h <sub>1</sub> [mm]	h <sub>2</sub> [mm]	h <sub>4</sub> * [mm]	h <sub>5</sub> [mm]	m [mm]	m <sub>1</sub> [mm]	m <sub>2</sub> [mm]	m <sub>3</sub> [mm]	m <sub>4</sub> [mm]	m <sub>5</sub> [mm]	n [mm]	n <sub>1</sub> [mm]	n <sub>2</sub> [mm]	n <sub>3</sub> [mm]	w* [mm]	w <sub>1</sub> * [mm]	approx. weight [kg]	
	size	50 Hz kW																					60 Hz kW
LEM 161	112 M	4.0	-	100	122	284	112	15	281	70	45	176	140	280	240	58	44	225	190	250	390	555	62
	132 M	-	6.0	110	132	304	132	18	320	60	88	218	178	320	278	-	55	256	216	276	426	591	90

other motors on request

\* dimensions dependent upon motor supplier

\*\* see list of accessories

**Dimensions LEL 91, LEL 126, LEL 161**

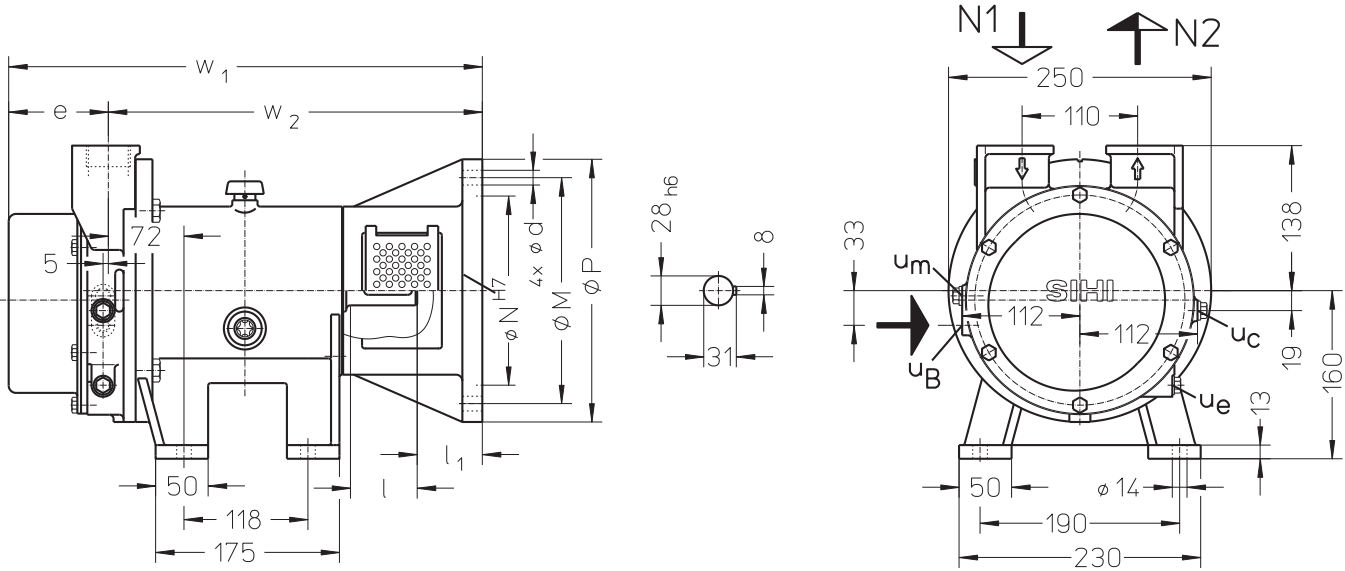

- N 1 = gas inlet G 1¼
- N 2 = gas outlet G 1¼
- u<sub>B</sub> = connection for service liquid G ¼

- u<sub>c</sub> = connection for cavitation protection G ¼
- u<sub>e</sub> = connection for drain G ¼
- u<sub>m</sub> = connection for pressure gauge G ¼

	electric motor 50 Hz		d [mm]	e [mm]	l [mm]	l <sub>1</sub> [mm]	M [mm]	N [mm]	P [mm]	w <sub>1</sub> [mm]	w <sub>2</sub> [mm]	approx. weight [kg]
	size	IP 55 kW										
LEL 91	90 L	2.2	M10	91	87,5	52	165	130	200	461	370	48
	100 L	-										
LEL 126	100 L	3.0	14	95	63,5	62	215	180	250	451	356	44
	112 M	-										

other motors on request

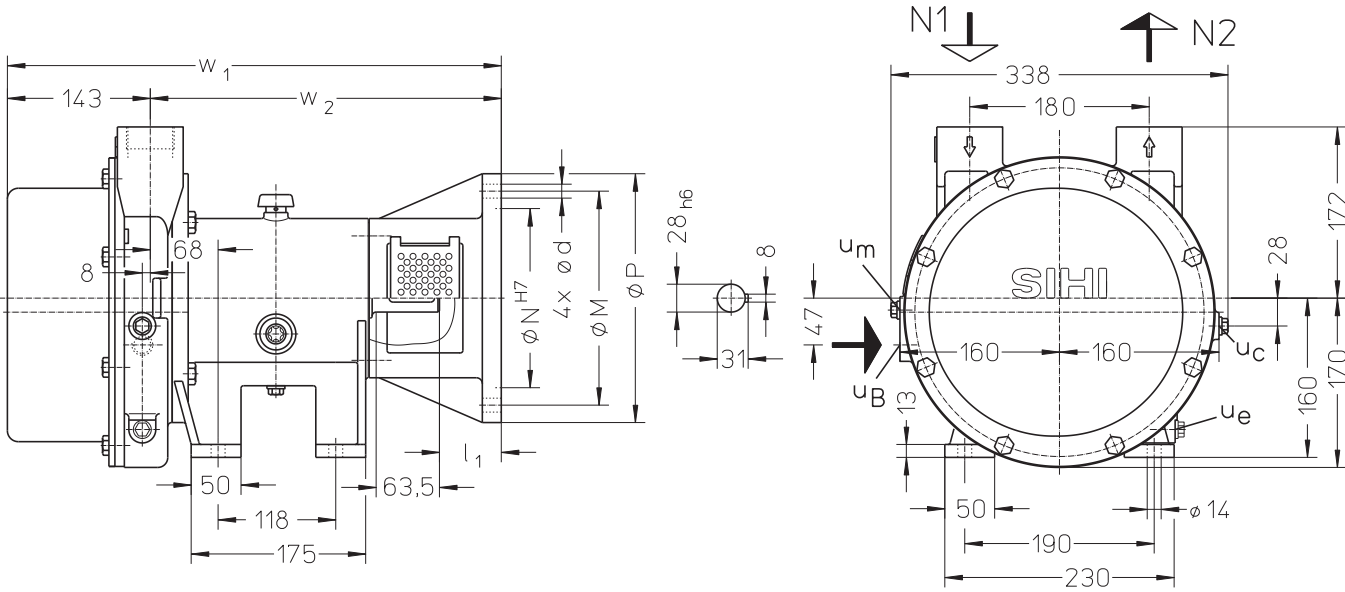

- N 1 = gas inlet G 1½
- N 2 = gas outlet G 1½
- u<sub>B</sub> = connection for service liquid G ½

- u<sub>c</sub> = connection for cavitation protection G ¼
- u<sub>e</sub> = connection for drain G ¼
- u<sub>m</sub> = connection for pressure gauge G ¼

	electric motor 50 Hz		d [mm]	l <sub>1</sub> [mm]	M [mm]	N [mm]	P [mm]	w <sub>1</sub> [mm]	w <sub>2</sub> [mm]	approx. weight [kg]
	size	IP 55 kW								
LEL 161	112 M	4.0	14	62	215	180	250	495	352	65
	132 S	-	5.0	M12	82	265	230	515	372	72

other motors on request



Arrangement drawing LEM 91, 126, 161

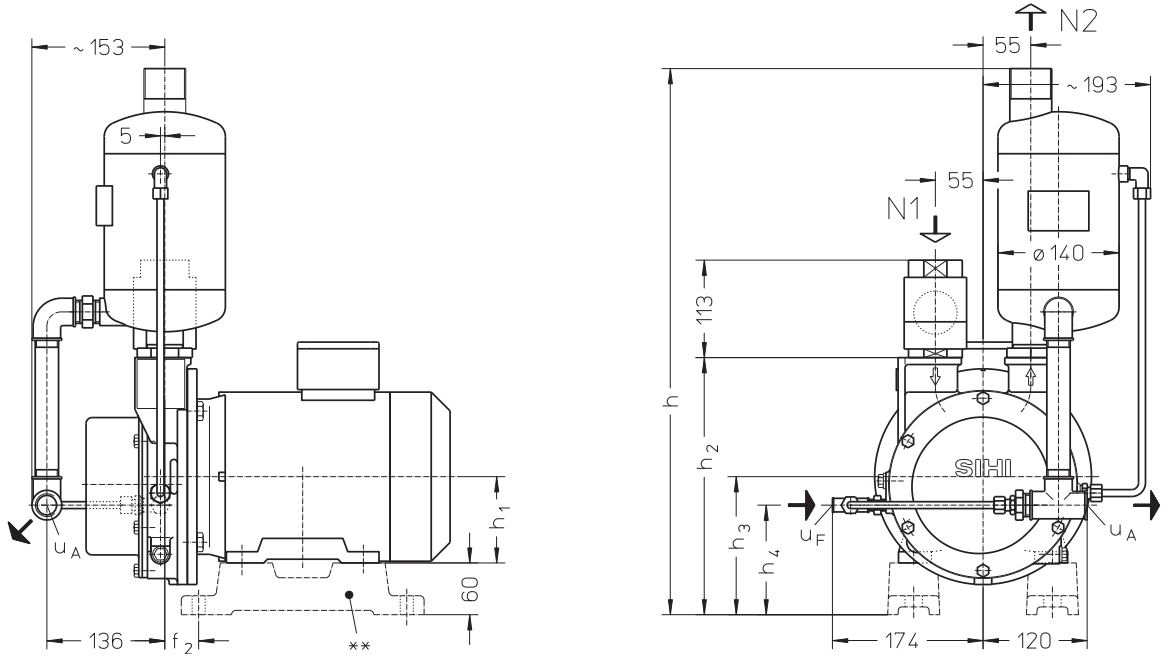

N 1 = gas inlet G 1¼

N 2 = gas outlet G 1½

U<sub>A</sub> = liquid drain G ¾

U<sub>F</sub> = connection for make-up liquid G ¼

	electric motor IP 55		f <sub>2</sub> [mm]	h [mm]	h <sub>1</sub> [mm]	h <sub>2</sub> [mm]	h <sub>3</sub> [mm]	h <sub>4</sub> [mm]	approx. weight [kg]
	size	kW							
LEM 91	90 L	2.2	25	623	90	288	150	117	41
	100 L	-	39	633	100	298	160	127	46
LEM 126	100 L	3.0	-	-	-	-	-	-	-
	112 M	-	46	645	112	310	172	139	51

other motors on request

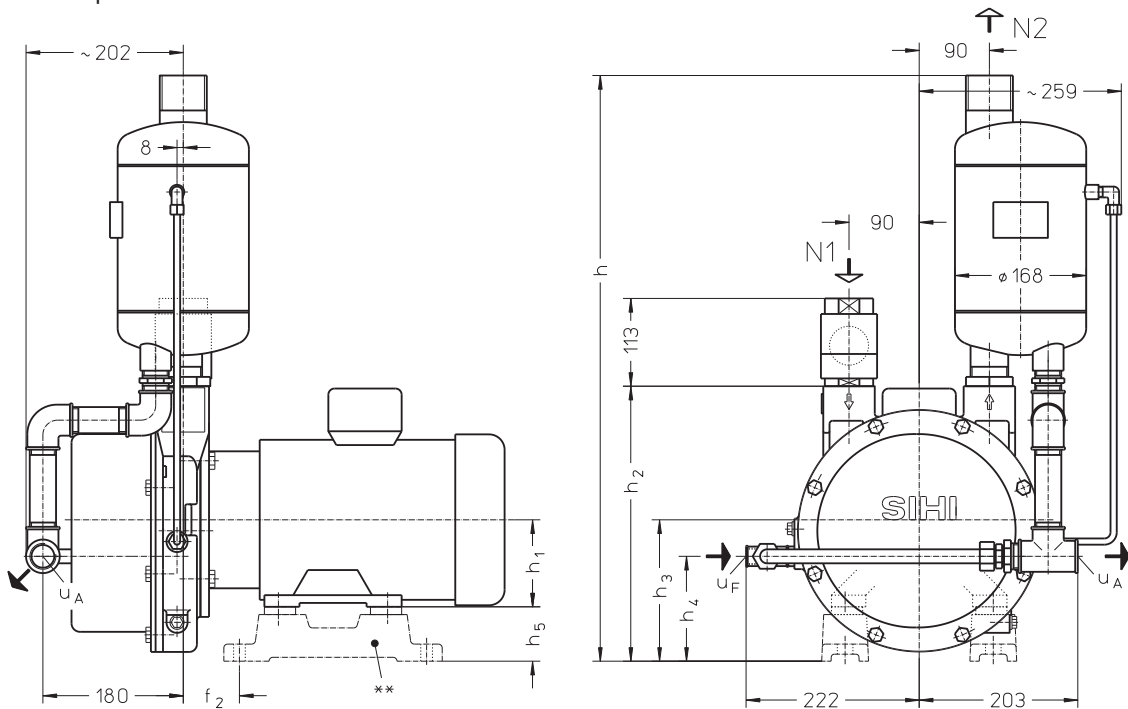

N 1 = gas inlet G 1½

N 2 = gas outlet G 2

U<sub>A</sub> = liquid drain G 1

U<sub>F</sub> = connection for make-up liquid G ½

	electric motor IP 55		f <sub>2</sub> [mm]	h [mm]	h <sub>1</sub> [mm]	h <sub>2</sub> [mm]	h <sub>3</sub> [mm]	h <sub>4</sub> [mm]	h <sub>5</sub> [mm]	approx. weight [kg]
	size	kW								
LEM 161	112 M	4,0	72	754	112	354	182	135	70	76
	132 M	-	82	764	132	364	192	145	60	104

other motors on request

Arrangement drawing LEM 91, 126, 161 with thermostatic control

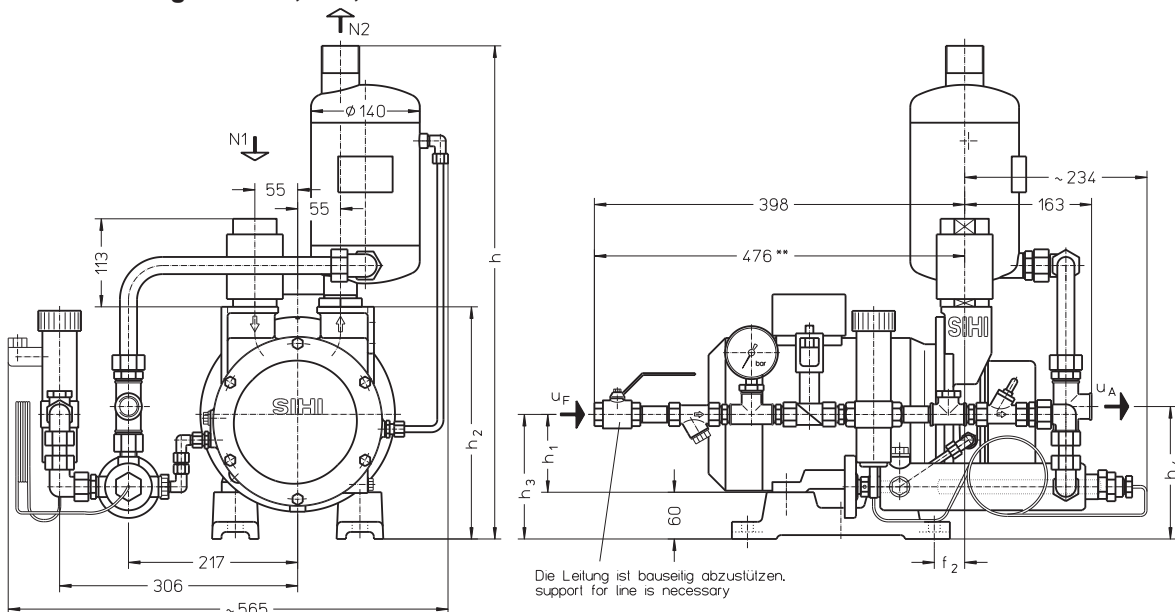

N 1 = gas inlet G 1¼  
 N 2 = gas outlet G 1½

U<sub>A</sub> = liquid drain G ¾  
 U<sub>F</sub> = connection for make-up liquid G ½

	electric motor IP 55		f <sub>2</sub> [mm]	h [mm]	h <sub>1</sub> [mm]	h <sub>2</sub> [mm]	h <sub>3</sub> [mm]	h <sub>4</sub> [mm]	approx. weight [kg]
	size	kW							
LEM 91	90 L	2.2	25	623	90	288	150	160	46
	100 L	-							
LEM 126	100 L	3.0	39	633	100	298	160	170	51
	112 M	-							

other motors on request  
 \*\* only at material 1.4571 the line

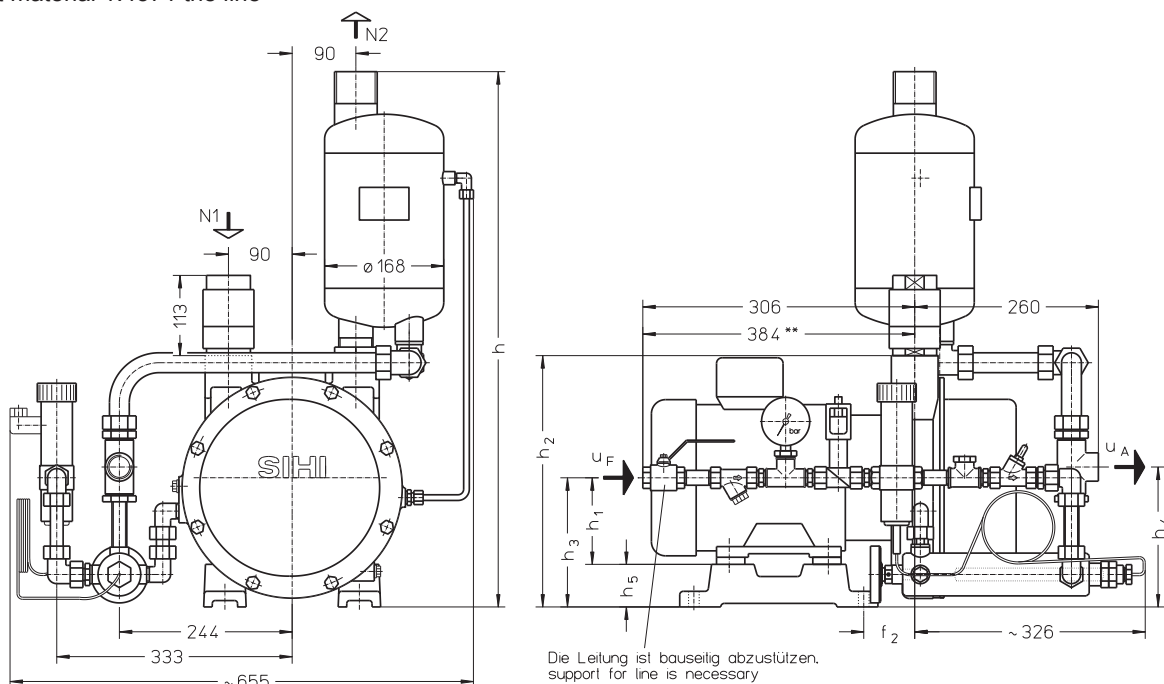

N 1 = gas inlet G 1½  
 N 2 = gas outlet G 2

U<sub>A</sub> = liquid drain G 1  
 U<sub>F</sub> = connection for make-up liquid G ½

	electric motor IP 55		f <sub>2</sub> [mm]	h [mm]	h <sub>1</sub> [mm]	h <sub>2</sub> [mm]	h <sub>3</sub> [mm]	h <sub>4</sub> [mm]	h <sub>5</sub> [mm]	approx. weight [kg]
	size	kW								
LEM 161	112 M	4.0	72	754	112	354	182	197	70	81
	132 M	-								

other motors on request  
 \*\* only at material 1.4571 the line

**Arrangement drawing LEL 91, 126, 161**

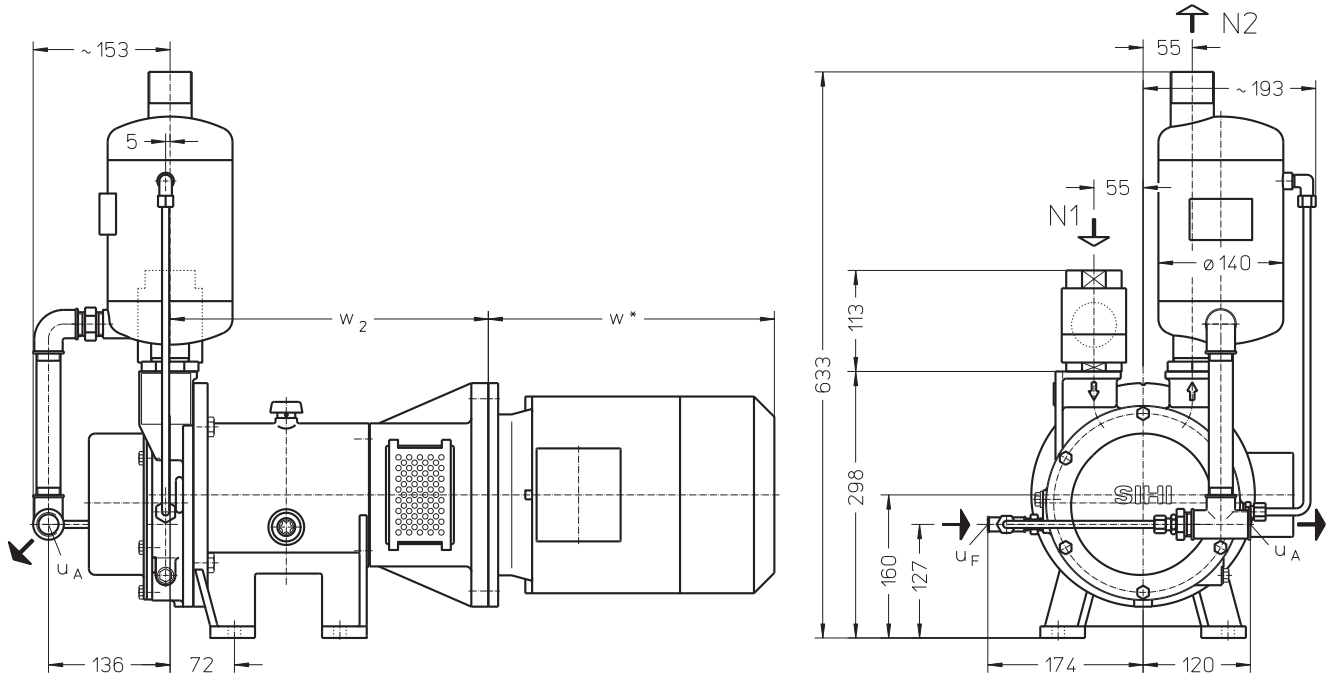

	electric motor 50 Hz			w *	w <sub>2</sub>	approx. weight
	size	IP 55	kW EEx e II T3			
LEL 91	90 L	2.2	-	269	370	72
	100 L	-	2.5	303		77
LEL 126	100 L	3.0	-		356	73
	112 M	-	3.3	320		83

other motors on request  
\* dimension dependent upon motor supplier

- N 1 = gas inlet G 1¼
- N 2 = gas outlet G 1½
- u<sub>A</sub> = liquid drain G ¾
- u<sub>F</sub> = connection for make-up liquid G ¼

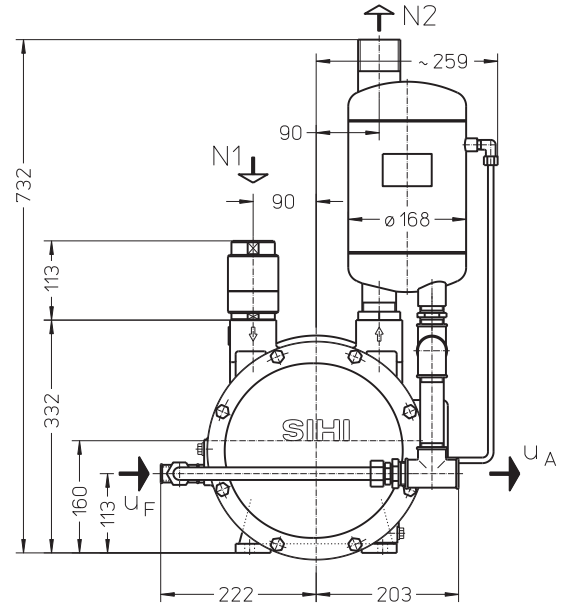
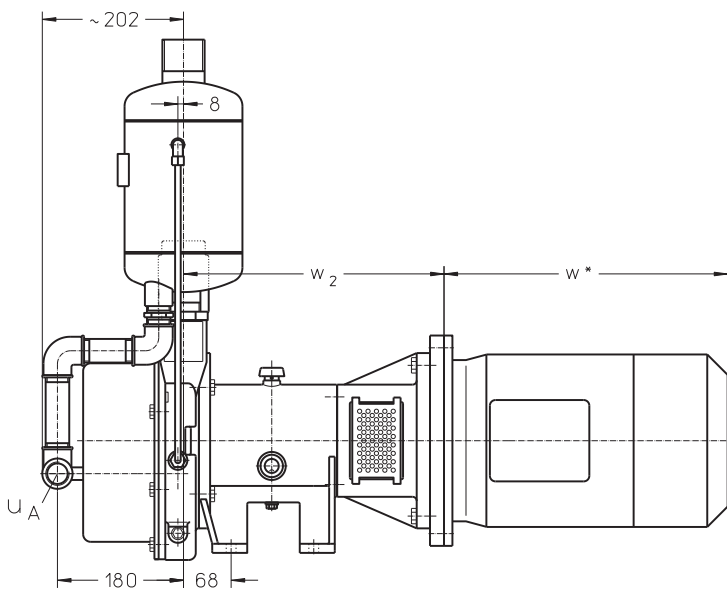

	electric motor 50 Hz			w *	w <sub>2</sub>	approx. weight
	size	IP 55	kW EEx e II T3			
LEL 161	112 M	4.0	-	320	352	105
	132 S	-	5.0	405	372	150

other motors on request  
\* dimension dependent upon motor supplier

- N 1 = gas inlet G 1½
- N 2 = gas outlet G 2
- u<sub>A</sub> = liquid drain G 1
- u<sub>F</sub> = connection for make-up liquid G ½

## Data regarding the pump size - order notes

range + size	hydraulic + bearings	shaft seal	materials	casing sealing	*code of motor connection*
	<ul style="list-style-type: none"> <li>A• hydraulic A,</li> <li>8• with threaded connection</li> <li>•Z two grease lubricated antifriction bearings arranged in the motor</li> <li>•B similar to •Z, but arranged in the motor carrier</li> </ul>	<ul style="list-style-type: none"> <li>AAE standard mechanical seal, o-rings butadiene rubber</li> <li>AA1 similar to AAE, but o-rings Viton</li> </ul>	<ul style="list-style-type: none"> <li>0K main parts out of cast iron, impeller in low alloyed steel</li> <li>4B main parts out of stainless steel</li> </ul>	0 liquid seal	<ul style="list-style-type: none"> <li>ES for IMB5 motor 90L flange ø200</li> <li>FS for IMB5 motor 100L resp. 112M flange ø250</li> <li>GS for IMB5 motor 132S flange ø300</li> </ul>
LEM	<ul style="list-style-type: none"> <li>91 AZ</li> <li>126</li> <li>161 8Z</li> </ul>	AAE, AA1	0K, 4B	0	<ul style="list-style-type: none"> <li>ES, FS</li> <li>FS</li> <li>FS, GS</li> </ul>
LEL	<ul style="list-style-type: none"> <li>91 AB</li> <li>126</li> <li>161 8B</li> </ul>				

\* = only LEL

### Motor selection

For our products we offer a lot of different motor types.  
To identify the right motor please specify frequency, voltage and protection class.

#### Example for ordering LEM:

LEM 126 AZ AAE 0K 0 **with** 3.0 kW AC motor 50 Hz, 230 VΔ, IP55

#### Example for ordering LEL:

LEL 161 8B AAE 0K 0 **for** 4.0 kW AC motor 50 Hz, 230 VΔ, IP55 (motor size 112) has the complete designation:

LEL 161 8B AAE 0K 0 **FS**

**Accessories LEM 91, 126, 161; LEL 91, 126, 161 with threaded connection**

Recommended Accessory	Material Execution		LEM 91 LEL 91	LEM 126 LEL 126	LEM 161 LEL 161
<b>Top Mounted Liquid Separator</b>		Type / weight	XBa 440 / 5 kg		XBa 640 / 7 kg
Top mounted separator	Steel, galvanised 1.4571	SIHI-Part No.	35 000 379 35 000 380		35 000 382 35 000 383
service liquid pipework, standard execution	1.0254 1.4571	SIHI-Part No.	20 037 865 20 038 838		20 059 452 20 061 181
service liquid pipework, thermostatic control 24V	1.0254 + Brass 1.4571 + Brass	SIHI-Part No.	20 048 243 20 048 244		20 048 245 20 048 246
Cavitation protection pipework	1.0254 1.4571	SIHI-Part No.	20 027 918 20 050 497		20 050 498 20 027 919
<b>Side Mounted Liquid Separator</b>		Type / weight	on request		
Side mounted separator	Steel, galvanised 1.4571	SIHI-Part No.			
service liquid pipework, standard execution	1.0254 1.4571	SIHI-Part No.			
Cavitation protection pipework	1.0254 1.4571	SIHI-Part No.			
<b>Sterling SIHI – Gas Ejector</b>					
at service liquid temperature 15 °C		Type Weight	GEV 91 A 3.6 resp. 3.8 kg	GEV 126 A 3.9 resp. 4.2 kg	GEV 161 A 4.7 resp. 5.0 kg
at service liquid temperature 30 °C		Type Weight	GEV 91 B 3.6 resp. 3.8 kg	GEV 126 B 3.9 resp. 4.2 kg	GEV 161 B 4.7 resp. 5.0 kg
<b>Sterling SIHI – Non Return Ball Valve</b>		Size Weight	G 1 ¼ 1.0 resp. 1.6 kg		G 1 ½ 1.9 kg
	Brass + Butadiene Rubber Brass + Teflon 1.4571 + Teflon	SIHI-Part No.	20 069 579 20 069 525 20 072 819		20 082 115 20 082 117 20 072 820
<b>Support foot</b>					
	only for LEM				
for motor size 90 L		SIHI-Part No.	20 047 009	-	-
for motor size 100 L, 112 M			20 047 010	20 047 010	20 047 011
for motor size 132 M			-	-	20 047 012
<b>Motor</b>		Size Power Weight	90 L 2.2 kW 15 kg	100 L 3.0 kW 20 kg	112 M 4.0 kW 28 kg
standard execution IP 55	only for LEL				
Coupling for motor IP 55		Type / weight SIHI-Part No.	B 68 / 1.5 kg 43 028 149 43 021 405	B 80 / 1.5 kg 43 021 414 43 021 417	
pump side					
motor side					
<b>Motor</b>		Size Power Weight	100 L 2.5 kW 22 kg	112 M 3.3 kW 28 kg	132 S 5.0 kW 65 kg
in EEx e II T3 execution	only for LEL				
Coupling for motor EEx e II T3		Type / weight SIHI-Part No.	BDS 88 / 1.9 kg 43 111 058 43 111 029		BDS 103 / 3.1 kg 43 111 051 43 111 040
pump side					
motor side					

Designs subject to change without prior notice.

**Sterling SIHI GmbH**

Lindenstraße 170, D-25524 Itzehoe, Germany

Telephone +49 (0) 48 21 / 7 71-01, Fax +49 (0) 48 21 / 7 71-274

www.sihi.com