

Liquid ring vacuum pumps

two-stage

LOH 25003, LOH 25007, LOH 25309

Pressure range: 33 to 1013 mbar
Suction volume flow: 11 to 60 m³/h

CONSTRUCTION TYPE

Sterling SIHI liquid ring vacuum pumps are displacement pumps of uncomplicated and robust construction with the following particular features:

- handling of nearly all gases and vapours
- non-polluting due to nearly isothermal compression
- oil-free, as no lubrication in the working chamber
- small quantities of entrained liquid can be handled
- easy maintenance and reliable operation
- low noise and nearly free from vibration
- wide choice of material, therefore applicable nearly everywhere
- protection against cavitation as standard
- no metallic contact of the rotating parts

Die Sterling SIHI liquid ring vacuum pumps LOH 25003, LOH 25007 and LOH 25309 are two-stage ones. They can be applied without modification as compressors (see catalogue section liquid ring compressors).

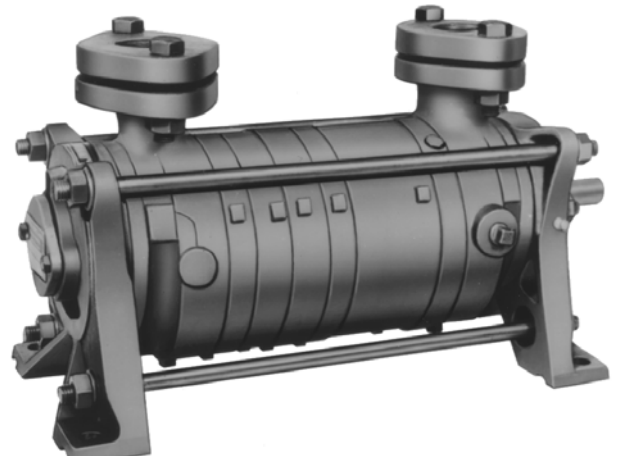

APPLICATION

Handling and exhausting of dry and humid gases; entrained liquid can be handled during normal duty. The pumps are applied in all fields where a pressure of 33 to 900 mbar must be created by robust vacuum pumps.

Fields of application are for example:

- chemistry and pharmacy for distilling and degassing
- electric industry for impregnation and drying
- plastics industry for degassing etc.

NOTE

During operation the pump must continuously be supplied with service liquid, normally water, in order to eliminate the heat resulting from the gas compression and to replenish the liquid ring, because part of the liquid is leaving the pump together with the gas. The liquid can be separated from the gas in a liquid separator (see catalogue part accessories).

It is possible to reuse the service liquid.

The direction of rotation is clockwise, when looking from the drive on the pump.

GENERAL TECHNICAL DATA

Pump type	unit	LOH 25003	LOH 25007	LOH 25309
Speed	50 Hz	2800	2800	2900
	60 Hz	3400	3400	3500
Max. compression over pressure	bar		2,6	
Max. admissible pressure difference	bar	2	2	1,2
Hydraulic test (over pressure)	bar		3	
Moment of inertial of the rotating pump parts and of the water filling	kg · m ²	0,004	0,0065	0,00875
Sound pressure level at suction pressure of 80 mbar		66	66	66
		67	67	67
Min. Pulley diameter permissible in case of V-belt drive		71	71	100
		80	80	
Max. gas temperature	dry		200	
	saturated		100	
Service liquid	max. admissible temperature		100	
	max. viscosity		90	
	max. density		1200	
	volume up to shaft level	Liter	1	1,2
Max. flow resistance of the heat exchanger	bar		0,2	

The combination of several limiting values is not admissible.

Material design

Item	COMPONENTS	MATERIAL DESIGN		
		01	02	42
0001, 0002	Casing	0.6025		1.4408
0035, 0036	Central body	0.6025 / 1.0570		
0010, 0011, 0012, 0013	Guide disk	0.6025		
0030, 0031	Vane wheel impeller	Rg9	1.4027.05	1.4517
0200	Shaft	1.4021		1.4401
0500, 0600	Mechanical seal	Cr Ni-steel / carbon / Perbunan		Cr Ni Mo-steel / carbon / Viton

Sectional drawing LOH 25003, LOH 25007, LOH 25309

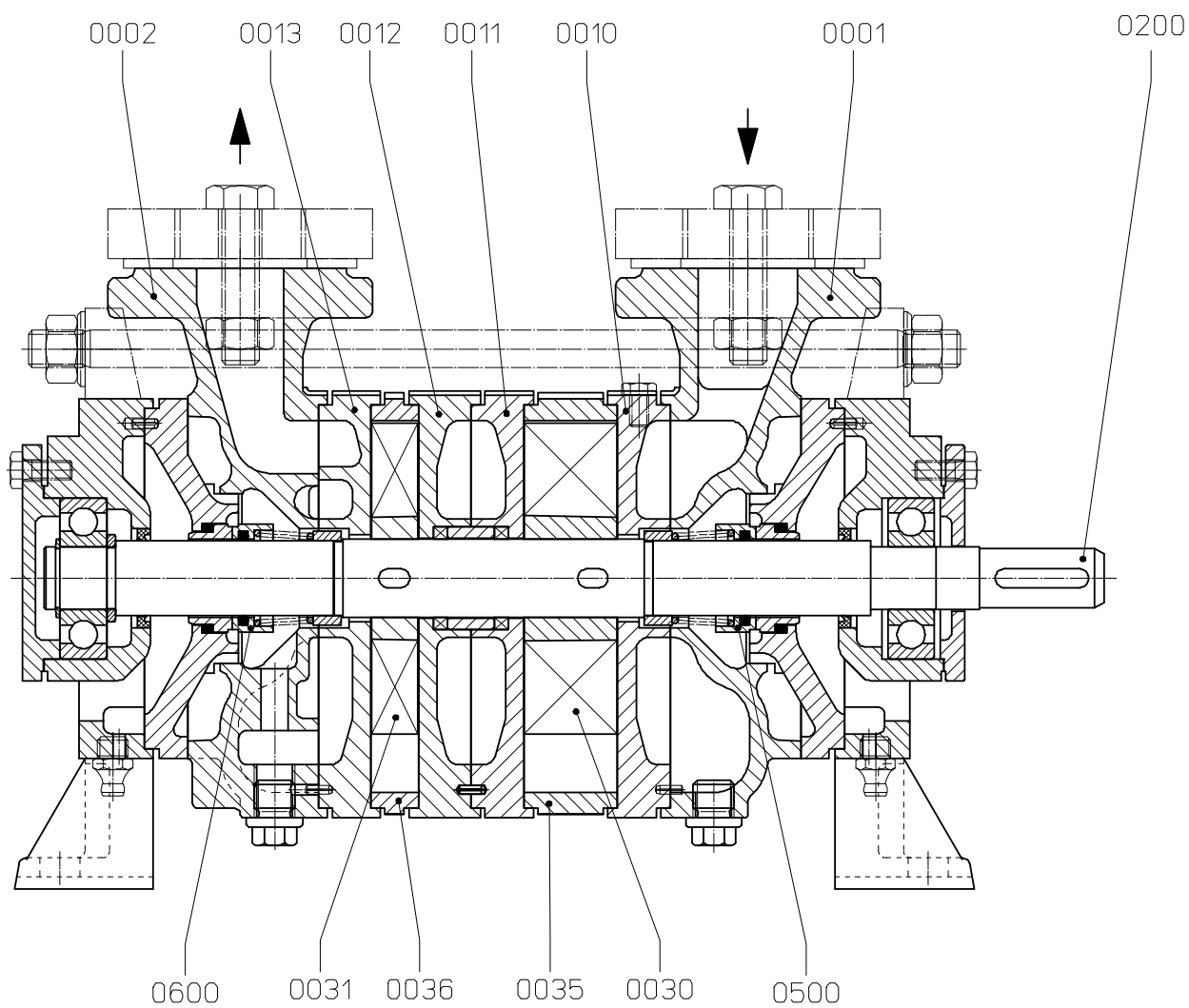

Suction volume flow and power absorption LOH 25003

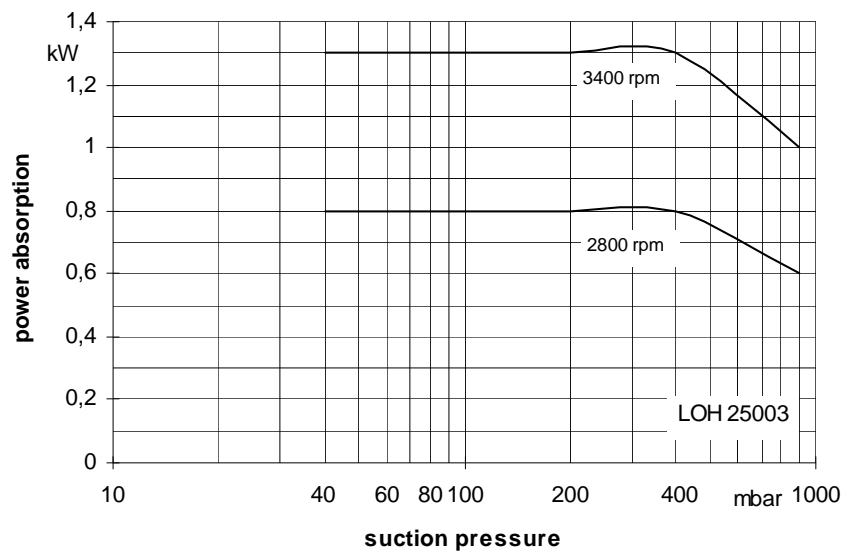
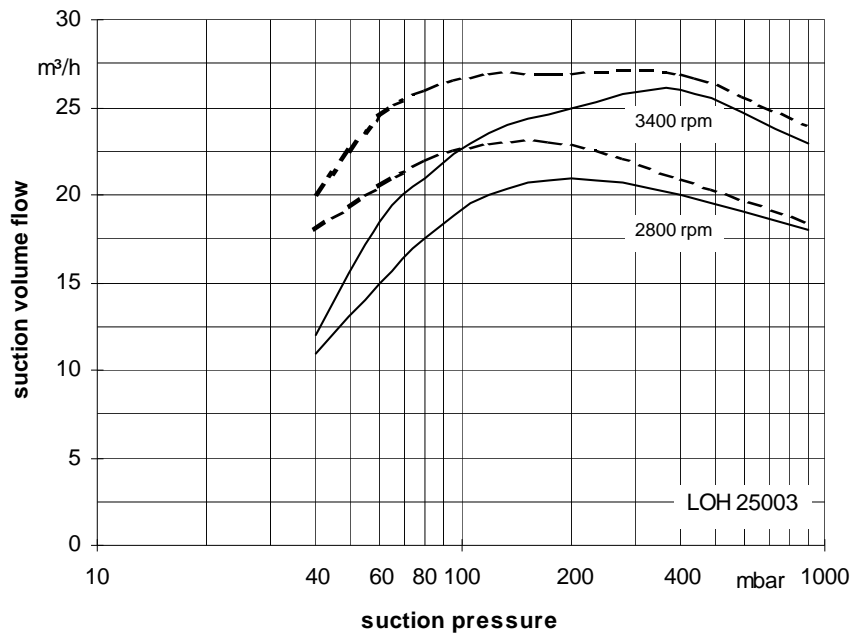

The operating data are applicable under the following conditions:

- pumping medium:
 - dry air: 20°C _____
 - water vapour saturated air: 20°C - - - - -
- service liquid:
 - water: 15°C

Compression pressure 1013 mbar (atmospheric pressure)

The suction volume flow is applied to the suction pressure

Tolerance of the operating data 10%

Max. fresh water need with the lowest suction pressure

Suction volume flow and power absorption LOH 25007

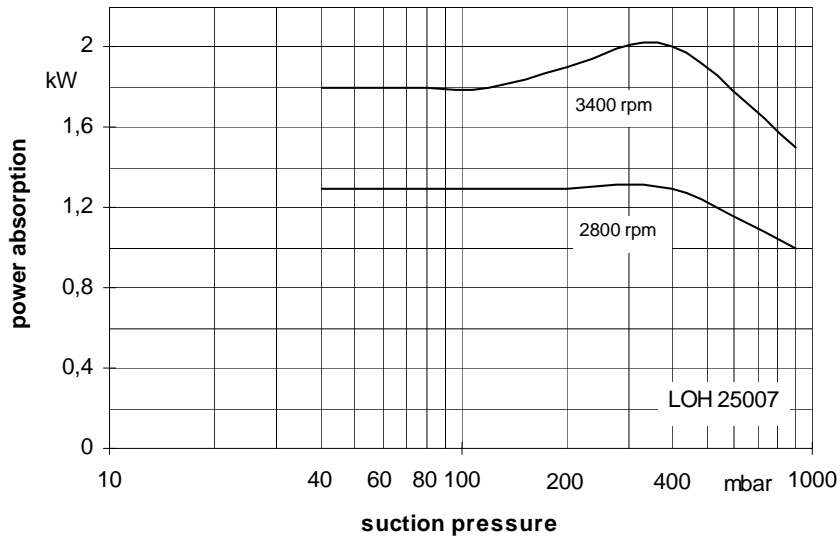
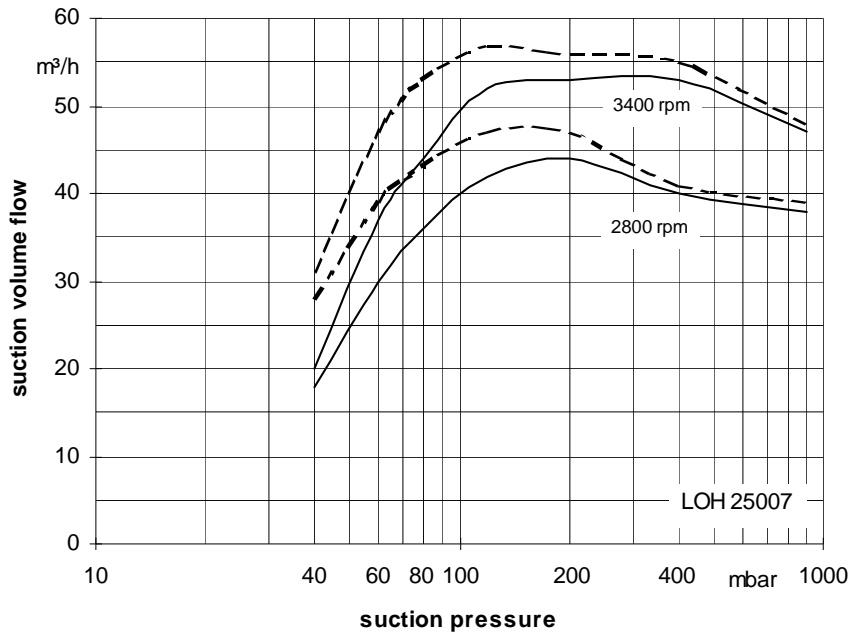

The operating data are applicable under the following conditions:

- pumping medium:
 - dry air: 20 °C _____
 - water vapour saturated air: 20°C - - - - -
- service liquid:
 - water: 15°C _____

Compression pressure 1013 mbar (atmospheric pressure)

The suction volume flow is applied to the suction pressure

Tolerance of the operating data 10%

Max. fresh water need with the lowest suction pressure

Suction volume flow and power absorption LOH 25309

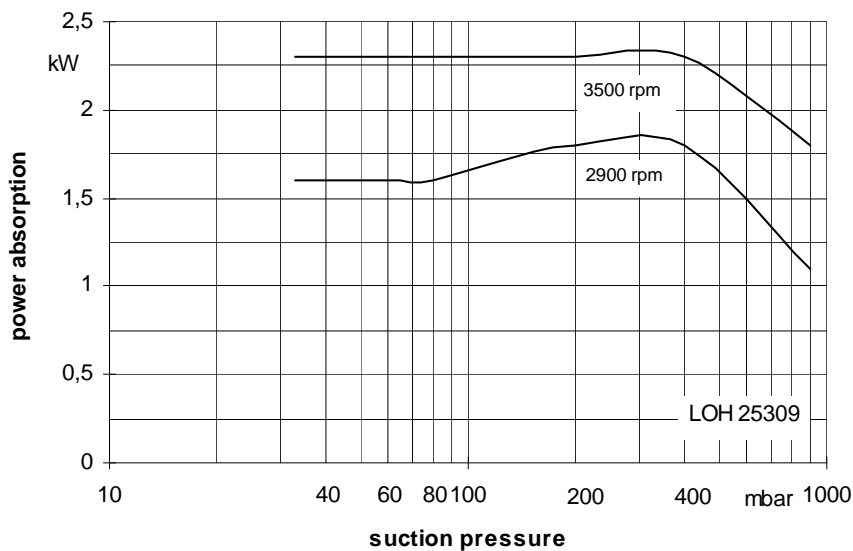
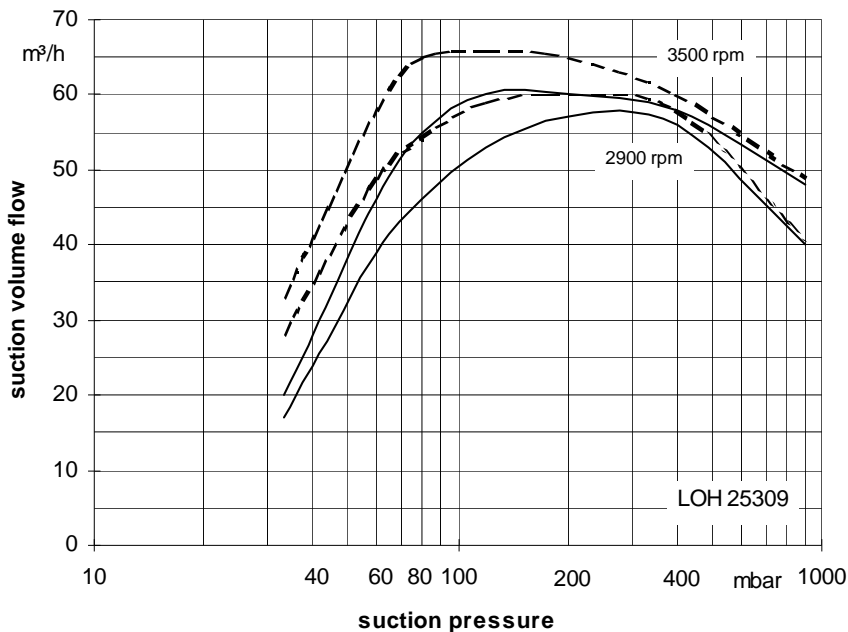

The operating data are applicable under the following conditions:

- pumping medium:
 - dry air: 20°C —————
 - water vapour saturated air: 20°C - - - - -
- service liquid:
 - water: 15°C

Compression pressure 1013 mbar (atmospheric pressure)
 The suction volume flow is applied to the suction pressure
 Tolerance of the operating data 10%
 Max. fresh water need with the lowest suction pressure

Dimension table LOH 25003, LOH 25007

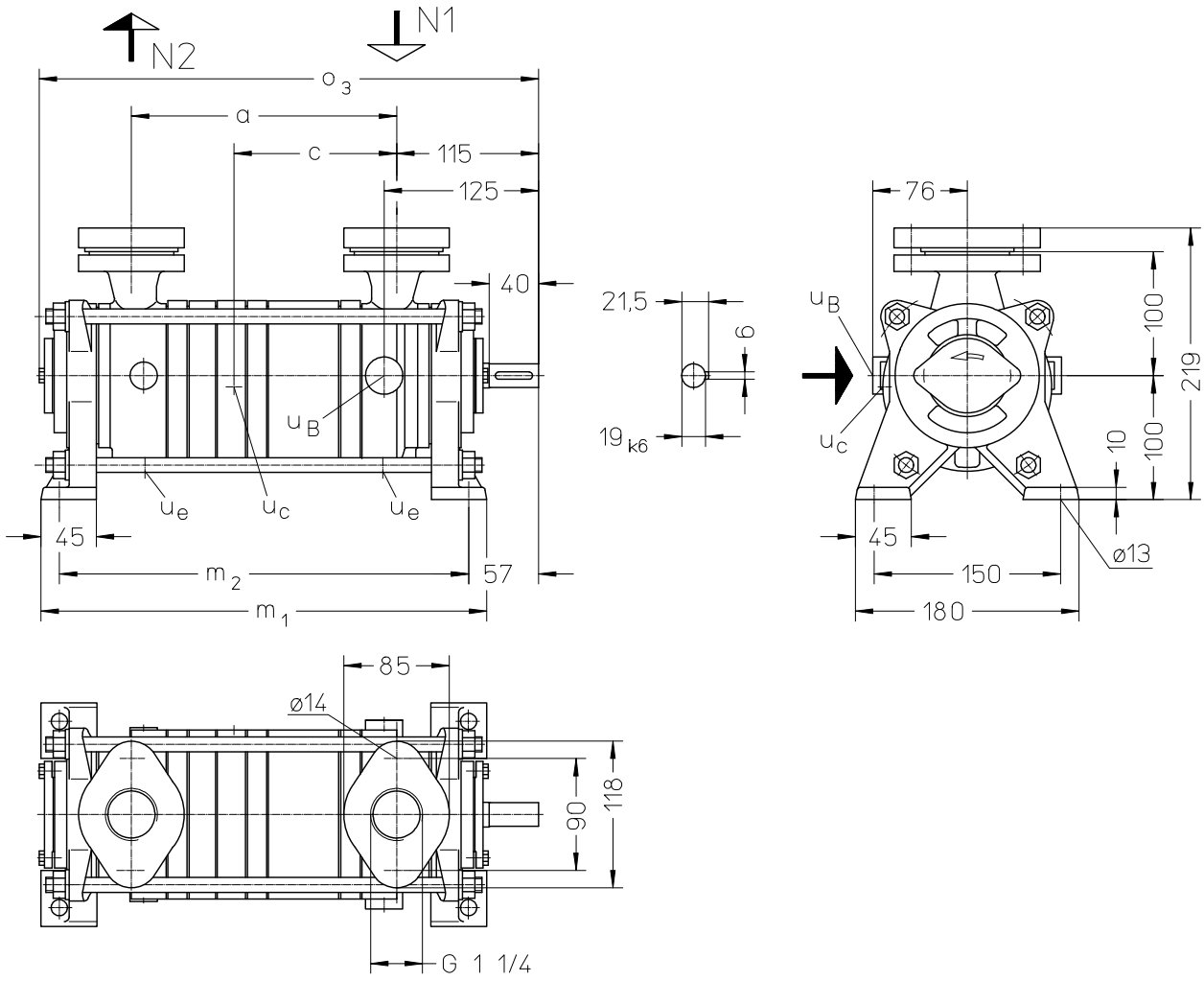

- N 1 = gas inlet G 1 ¼
- N 2 = gas outlet G 1 ¼
- u B = connection for service liquid G ¾
- u c = connection for protection against cavitation G 1/8
- u e = drain connection G ¼

Oval counter flanges are part of the design.

	a	c	m 1	m 2	o 3	weight abt. kg
LOH 25003	163	96	309	279	348	22
LOH 25007	213	131	359	329	398	23

Arrangement drawing LOH 25003, LOH 25007 with overhead liquid separator

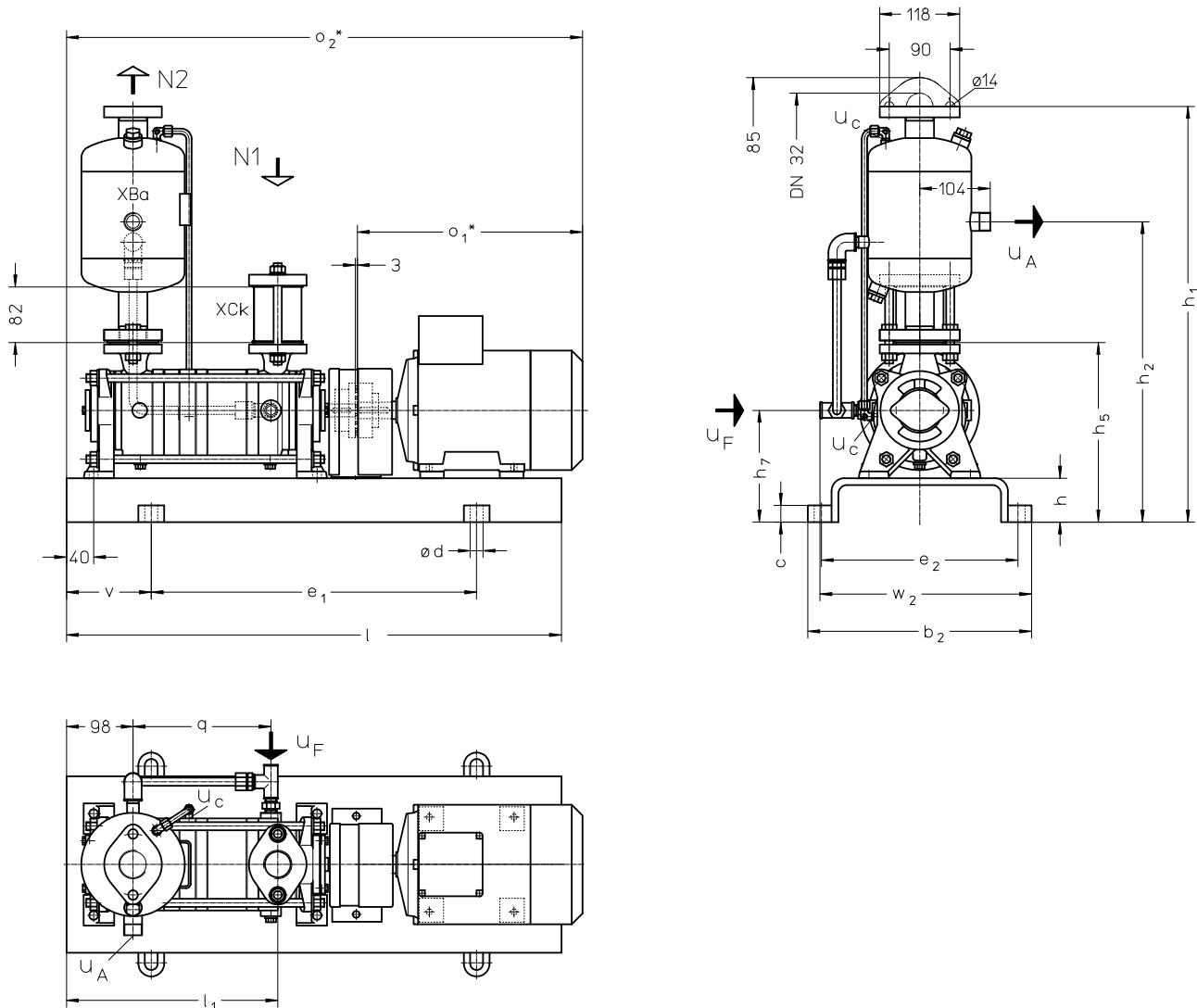

- N 1 = gas inlet G 1 ¼
- N 2 = gas outlet DN 32
- U A = connection for liquid drain R ¾
- U C = connection for protection against cavitation G 1/8
- U F = connection for fresh liquid G 3/8

Oval flanges according to DIN 2558 PN 6.

	electric motor 50 Hz			b ₂	c	d	e ₁	e ₂	h	h ₁	h ₂	h ₅	h ₇	l	l ₁	o ₁ *	o ₂ *	q	v	w ₂	weight abt. kg
	size	kW	IP 55 EEx e II T3																		
LOH 25003	80	1,1	-	297	20	15	400	265	40	585	415	240	140	640	262	274	653	153	120	292	33
	80	-	1,1																		35
LOH 25007	90S	1,5	-	330	25	19	480	290	65	610	440	265	165	730	311	332	761	204	125	312	50
	90L	-	2																		54

* dimensions dependent on the motor make

Dimension table LOH 25309

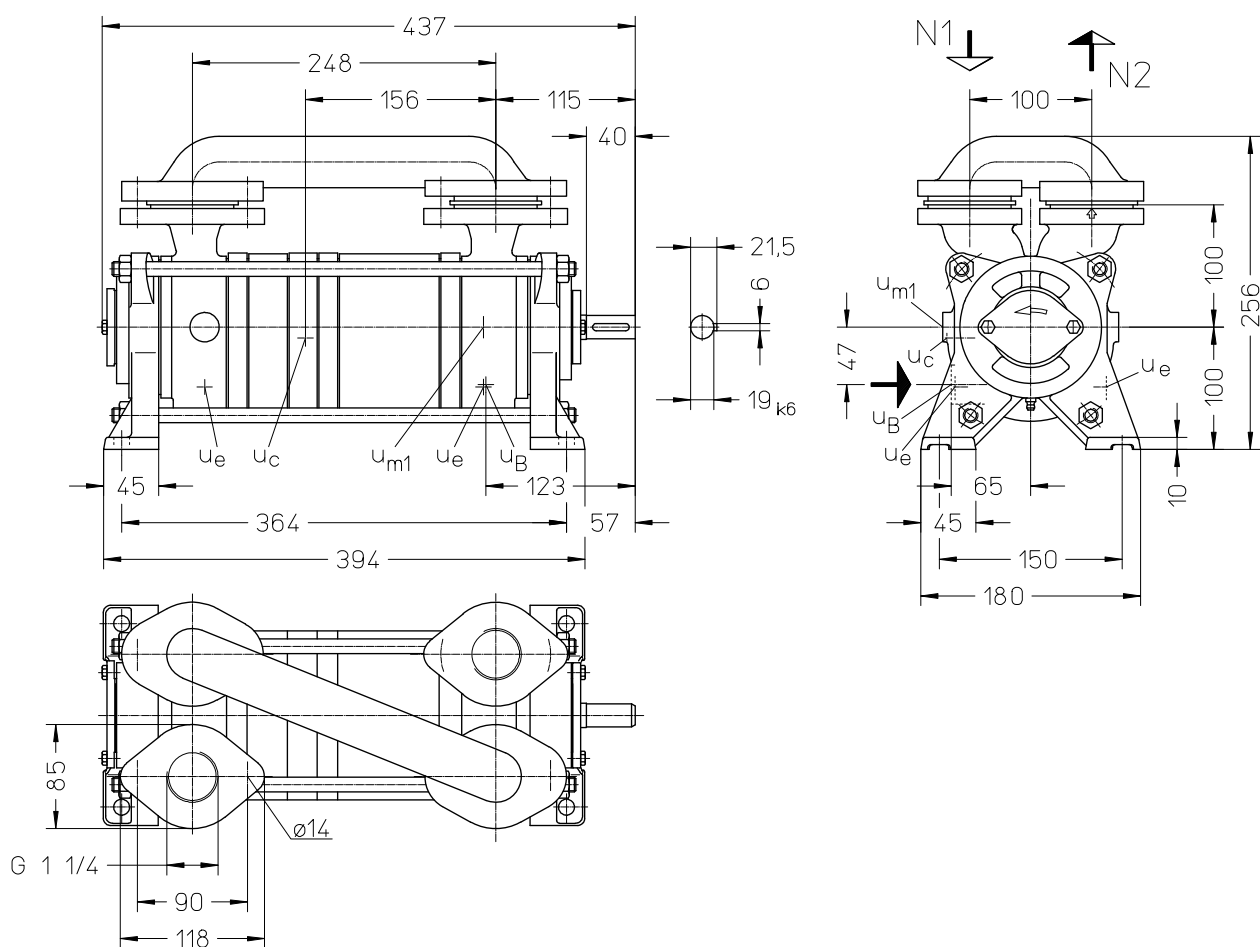

- N 1 = gas inlet G 1 ¼
- N 2 = gas outlet G 1 ¼
- u B = connection for service liquid G ½
- u c = connection for protection against cavitation G ⅛
- u e = drain connection G ¼
- u m1 = connection for drain valve G ¼

oval counter flanges are part of the design

Arrangement drawing LOH 25309 with overhead liquid separator

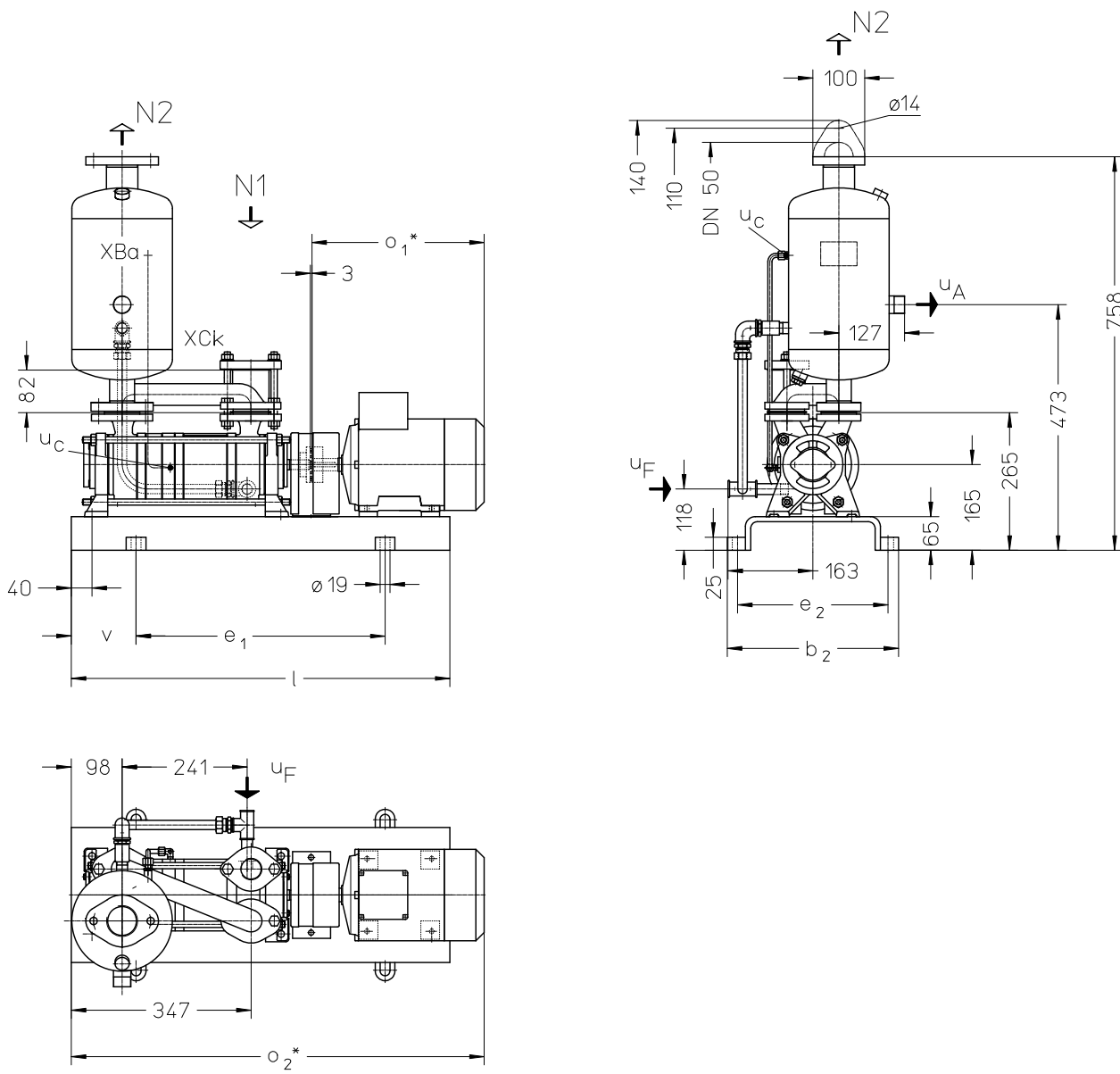

- N 1 = gas inlet G 1 ¼
- N 2 = gas outlet DN 50
- u A = connection for liquid drain R 1
- u c = connection for protection against cavitation G 1/8
- u F = connection for fresh liquid G 1/2

oval flanges to DIN 2558 PN 6

	electric motor 50 Hz			b ₂	e ₁	e ₂	l	v	o ₁ *	o ₂ *	weight abt. kg
	size	IP 55	kW EEx e II T3								
LOH 25309	90L	2,2	-	330	480	290	730	125	332	796	57
	100L	-	2,5	360	540	320	820	140	363	827	70

* dimensions dependent on the motor make

Fresh water requirements in [m³/h] dependent on suction pressure, speed, mode of operation and difference in temperature

Suction pressure in mbar		40				120				200				400						
pump	speed [rpm]	KB			FB	KB				FB	KB				FB					
		difference in temperature °C				difference in temperature °C					difference in temperature °C									
		10	5	2		20	10	5	2		20	10	5	2		20	10	5	2	
LOH 25003	2800	0,06	0,10	0,17	0,35	0,03	0,06	0,09	0,16	0,3	0,03	0,06	0,09	0,16	0,3	0,03	0,05	0,09	0,15	0,26
	3400	0,08	0,14	0,22		0,05	0,08	0,13	0,20		0,05	0,08	0,13	0,20		0,05	0,08	0,12	0,18	
LOH 25007	2800	0,08	0,14	0,22	0,35	0,05	0,08	0,13	0,20	0,3	0,05	0,08	0,13	0,20	0,3	0,05	0,08	0,12	0,18	0,26
	3400	0,11	0,16	0,24		0,06	0,10	0,15	0,22		0,06	0,11	0,16	0,22		0,06	0,10	0,15	0,20	
LOH 25309	2900	0,12	0,20	0,36	0,75	0,07	0,12	0,21	0,36	0,71	0,07	0,13	0,21	0,36	0,68	0,07	0,12	0,20	0,32	0,55
	3500	0,16	0,27	0,47		0,09	0,16	0,27	0,46		0,09	0,16	0,27	0,45		0,09	0,15	0,25	0,39	

FB = fresh liquid service

KB = combined liquid service with service water 20 °C, 10 °C, 5 °C, 2 °C warmer than the fresh water.

Data regarding the pump size - order notes

series + size	bearings + sence of rotation	shaft sealing	material design	casing seal
	<ul style="list-style-type: none"> • B two grease lubricated antifriction bearing • N one shaft end clockwise rotating 	131 mechanical seal	01 main parts of GG 02 main parts of GG without non-ferrous metal 42 main parts of Cr Ni Mo-cast steel	0 liquid seal
LOH 25003 25007 25309	BN	131	01, 02, 42	0

Design - Motor selection table

	designation	electric motor 50 Hz					
		motor enclosure IP 55			motor enclosure EEx e II T3		
pump with free shaft end	01	kW	size	designation	kW	size	designation
pump with coupling, pre-drilled at motor side	04						
at above, but with motor, for example 1,5 kW three-phase motor 50 Hz, 230/400 V at 2800 rpm	e.g. HA	1,1	80 B	GA	1,1	80 B	GJ
		1,5	90 S	HA	2,0	90 L	JJ
		2,2	90 L	JA	2,5	100 L	KJ

Example for ordering:

The construction size LOH. 25007 BN 131 02 0 with 1,5 kW three-phase motor (50 Hz, 230/400 V, 2800 rpm, IP55) has the complete order number:

LOH• 25007 BN 131 02 0 HA

If motors with other voltage or frequency are required a special information should be given.

On delivery the point (•) in the fourth place of the type code is replaced by a letter in the factory.

Accessories

Recommended accessories		LOH 25003	LOH 25007	LOH 25309
Overhead liquid separator material design 130 / St galvanized 172 / 1.4571 service liquid line material design 072 / St 37-0 172 / 1.4571 cavitation protection line material design 072 / St 37-0 172 / 1.4571	type weight	XBa 342 5 kg		XBa 1041 10 kg
	SIHI part No.	35 000 377 35 000 378		35 000 393 35 000 394
	SIHI part No.	20 054 559 20 054 560		20 054 886 20 054 887
	SIHI part No.	20 050 509 20 050 512	20 050 510 20 050 513	20 050 511 20 050 514
SIHI-gas ejector at service liquid temperature	15 + 30 °C	-	GOV 3211	GOV 3212
SIHI-ball non-return valve material design 767 / 0.6025+Perbunan 784 / 1.4408+Teflon	type / weight SIHI part No.	XCK 32 / 1,2 resp. 3 kg 20 072 744 20 029 488		
Motor in case of standard design IP 55 EEx e II T3	size power weight	80 B 1,1 kW 10 kg	90 S 1,5 kW 13 kg	90 L 2,2 kW 15 kg
	size power weight	80 B 1,1 kW 12 kg	90 L 2 kW 16 kg	100 L 2,5 kW 22 kg
Coupling for motor IP 55 pump side motor side for motor EEx e II T3 pump side motor side	type / weight SIHI part No.	43 021 420	B 80 / 1,5 kg 43 021 409 43 039 231	43 039 231
	type / weight SIHI part No.		43 025 933	BDS 88 / 2 kg 43 024 676 43 028 108
Contact safety device material design 076 / steel 345 / 2.0321	SIHI part No.	43 042 201 43 042 202		
Base frame for motor IP 55 material design 081 / 1.0038 for motor EEx e II T3 material design 081 / 1.0038	type / weight SIHI part No.	S 008 / 10 kg 43 040 648	S 241 / 23,5 kg 43 040 631	S 241 / 23,5 kg 43 040 631
	type / weight SIHI part No.	S 008 / 10 kg 43 040 648	S 241 / 23,5 kg 43 040 631	S 272 / 28,3 kg 43 040 633

Any changes in the interest of the technical development are reserved.

Sterling SIHI GmbH

Lindenstraße 170, D-25524 Itzehoe, Germany, Telephone +49 (0) 48 21/ 7 71 - 01, Fax +49 (0) 48 21/ 771-274