

# Liquid ring vacuum pumps

## single-stage

## LPH 80540, LPH 80553

**Suction range:** 120 to 1013 mbar  
**Suction volume flow:** 1500 to 3300 m<sup>3</sup>/h

### CONSTRUCTION TYPE

Sterling SIHI liquid ring vacuum pumps are displacement pumps of uncomplicated and robust construction with the following particular features:

- Handling of nearly all gases and vapours
- non-polluting due to nearly isothermal compression
- oil-free, as no lubrication in the working chamber
- small quantities of entrained liquid can be handled
- easy maintenance and reliable operation
- low noise and nearly free from vibration
- wide choice of material, therefore applicable nearly everywhere
- incorporated dirt drain
- incorporated central drain
- no metallic contact of the rotating parts

The Sterling SIHI liquid ring vacuum pumps LPH 80540 and LPH 80553 are single-stage ones. They can be applied with small modification as compressors up to a compression pressure of 1,5 bar (see catalogue part K).

### APPLICATION

Handling and exhausting of dry and humid gases; entrained liquid can be handled during normal duty. The pumps are applied in all fields where a pressure of 120...900 mbar must be created by robust vacuum pumps.

- Fields of application are for example
- chemistry and pharmacy for distilling and degassing
  - electric industry for impregnation and drying
  - plastics industry for degassing etc.



### NOTE

During operation the pump must continuously be supplied with service liquid, normally water, in order to eliminate the heat resulting from the gas compression and to replenish the liquid ring, because part of the liquid is leaving the pump together with the gas. This liquid can be separated from the gas in a liquid separator ( see catalogue part accessories).

It is possible to reuse the service liquid. The pumps are equipped with a device by which the contaminated service liquid can continuously be drained during operation (dirt drain), if necessary. The direction of rotation is clockwise, when looking from the drive on the pump.

### GENERAL TECHNICAL DATA

Pump type	unit	LPH 80540			LPH 80553		
Speed	1/min	585	735 <sup>1)</sup>	880	585	735 <sup>1)</sup>	880
Max. compression over pressure	bar				1,5		
Max. admissible pressure difference	bar	1,5	1,5	1,2 <sup>2)</sup>	1,5	1,5	1,2 <sup>2)</sup>
Hydraulic test (over pressure)	bar				3		
Moment of inertial of the rotating pump parts and the water filling	kg · m <sup>2</sup>		7,5			10,5	
Sound pressure level at a suction pressure of 200 mbar	dB (A)	83	83	85	83	83	85
Min. pulley diameter admissible in case of V-belt drive	mm	315	315	400	500	500	560
Max. gas temperature	°C				160		
	dry						
	saturated				80		
Service liquid							
max. admissible temperature	°C				60		
max. viscosity	mm <sup>2</sup> /s				90		
max. density	kg/m <sup>3</sup>				1200		
volume up to shaft level	liter	50				65	
Max. flow resistance of the heat exchanger	bar				0,2		

The combination of several limiting values is not admissible.

<sup>1)</sup> normal speed

<sup>2)</sup> with V-belt drive

## Material design

Pos.	COMPONENTS	MATERIAL DESIGN	
		02	42
0001, 0002	Casing	0.6025	1.4408
0010, 0011	Guide disk	0.6025	1.4408
0030	Vane wheel impeller	1.0570	1.4571
0035	Central body	1.0038	1.4571
0200	Shaft	1.0503	
0270	Shaft sleeve	1.4027.05	1.4581
0400	Gland packing	GORE	
0500, 0600	Mechanical seal	Cr-steel / carbon / Viton	SiC / carbon / Viton

## Sectional drawing LPH 80540, LPH 80553

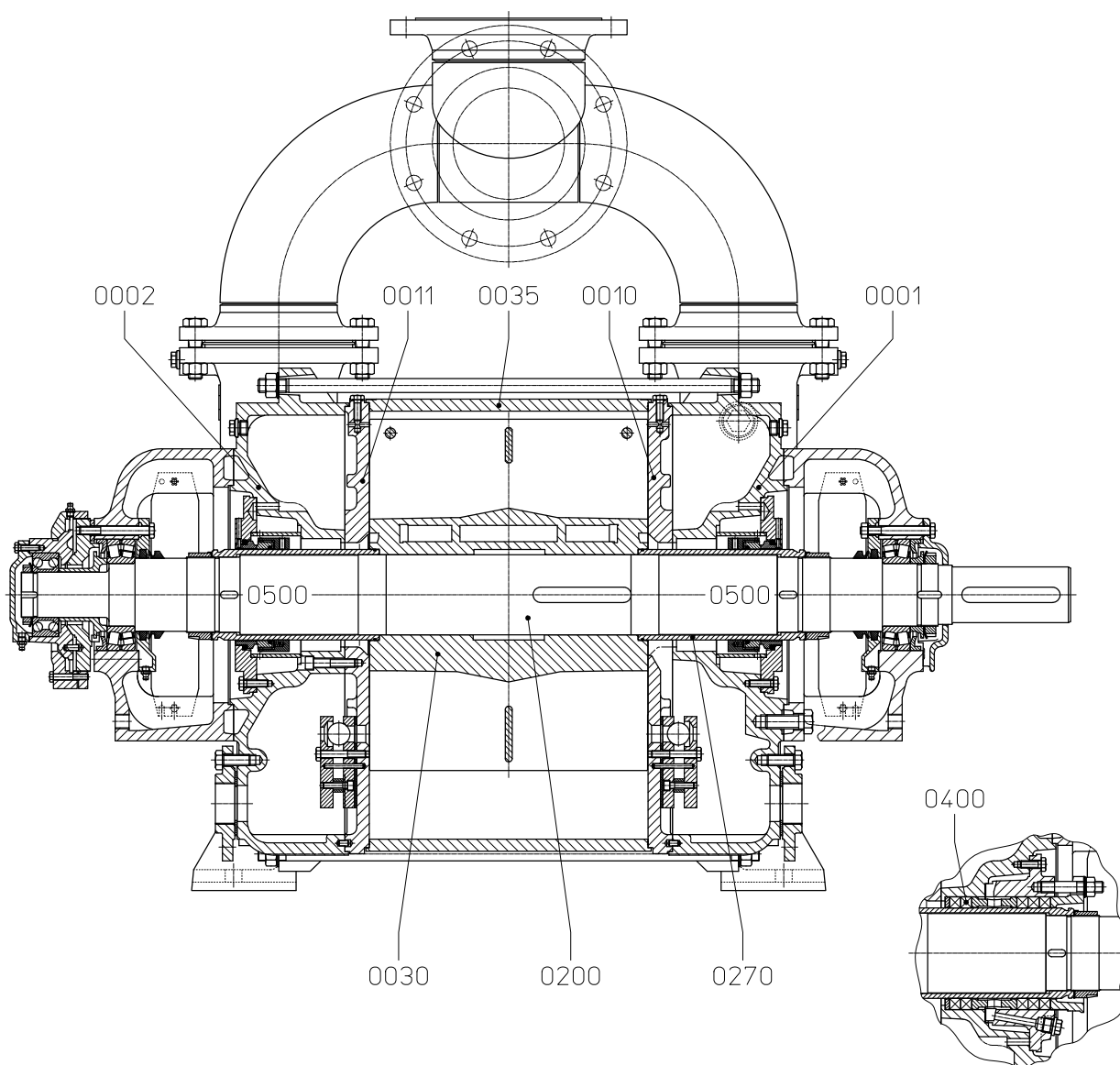

**Suction volume flow and power absorption LPH 80540**

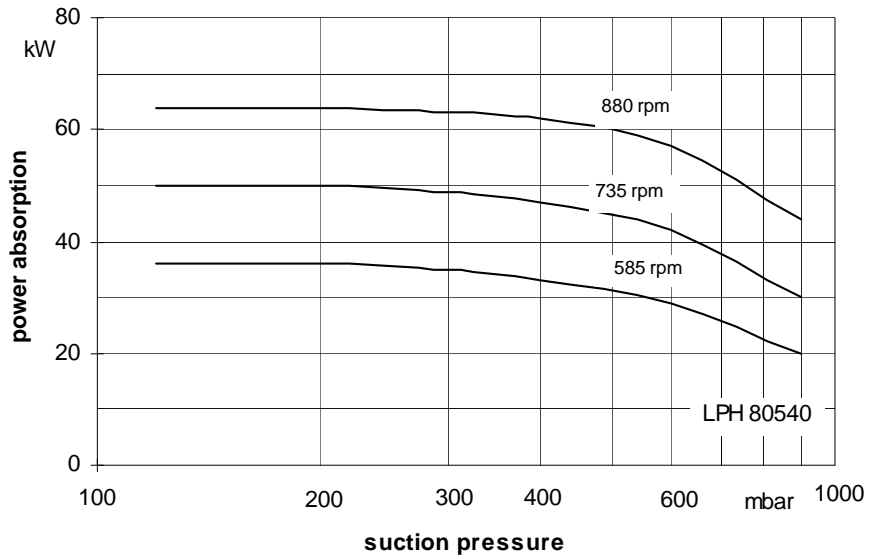
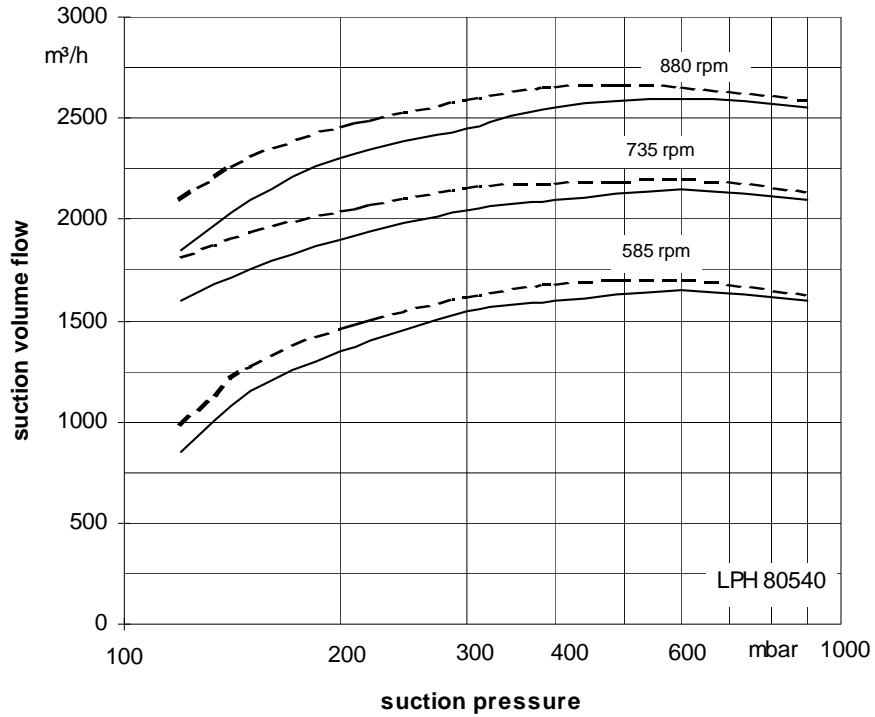

The operating data are applicable under the following conditions:

- pumping medium:
  - dry air: 20°C —————
  - water vapour saturated air: 20°C - - - - -
- service liquid:
  - water: 15°C

Compression pressure 1013 mbar (atmospheric pressure)

The suction volume flow is applied to the suction pressure.

Tolerance of the operating data 10% and of the power absorption 5%

Max. fresh water need with the lowest suction pressure

# Suction volume flow and power absorption LPH 80553

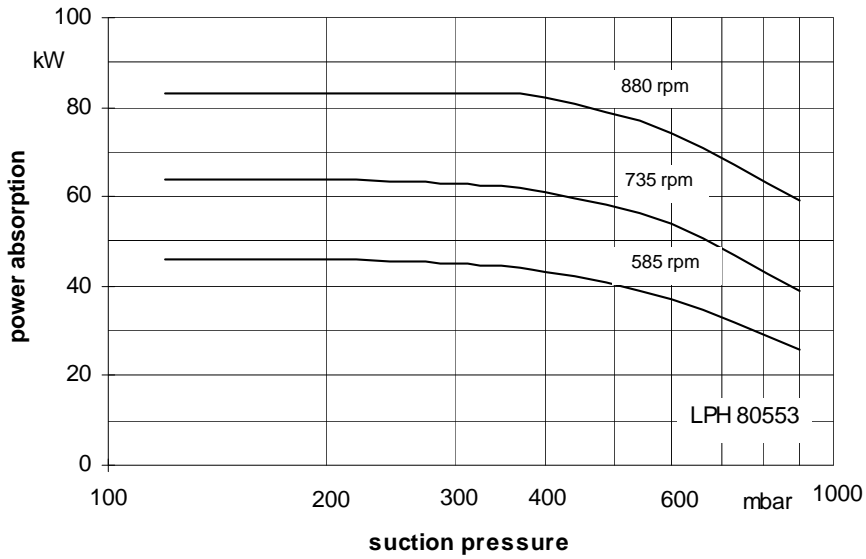
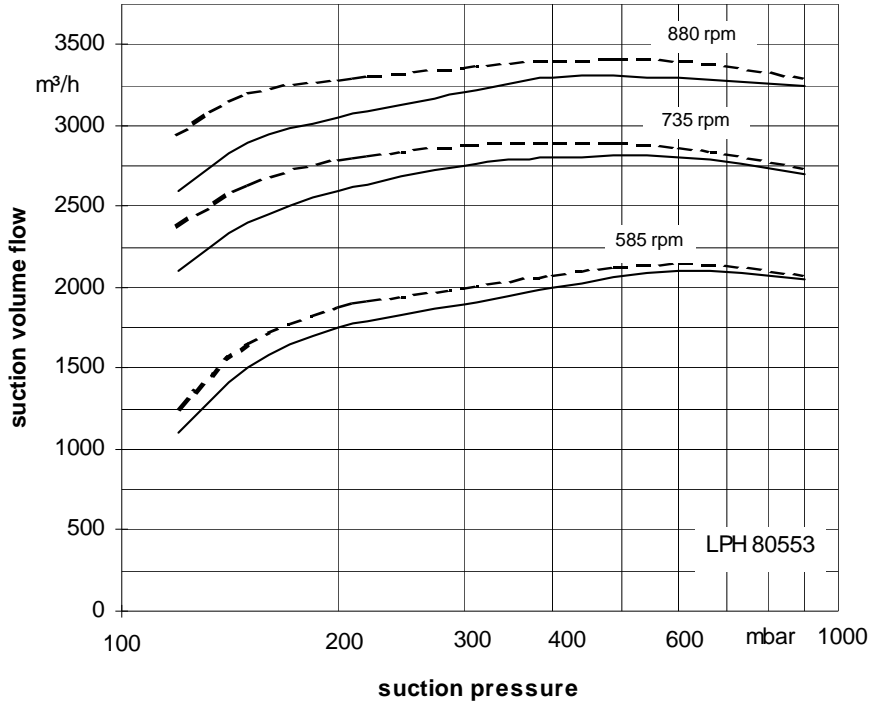

The operating data are applicable under the following conditions:

- pumping medium:
  - dry air: 20°C
  - water vapour saturated air: 20°C
- service liquid:
  - water: 15°C

Compression pressure 1013 mbar (atmospheric pressure)

The suction volume flow is applied to the suction pressure.

Tolerance of the operating data 10% and of the power absorption 5%

Max. fresh water need with the lowest suction pressure

**Dimension table LPH 80540, LPH 80553**

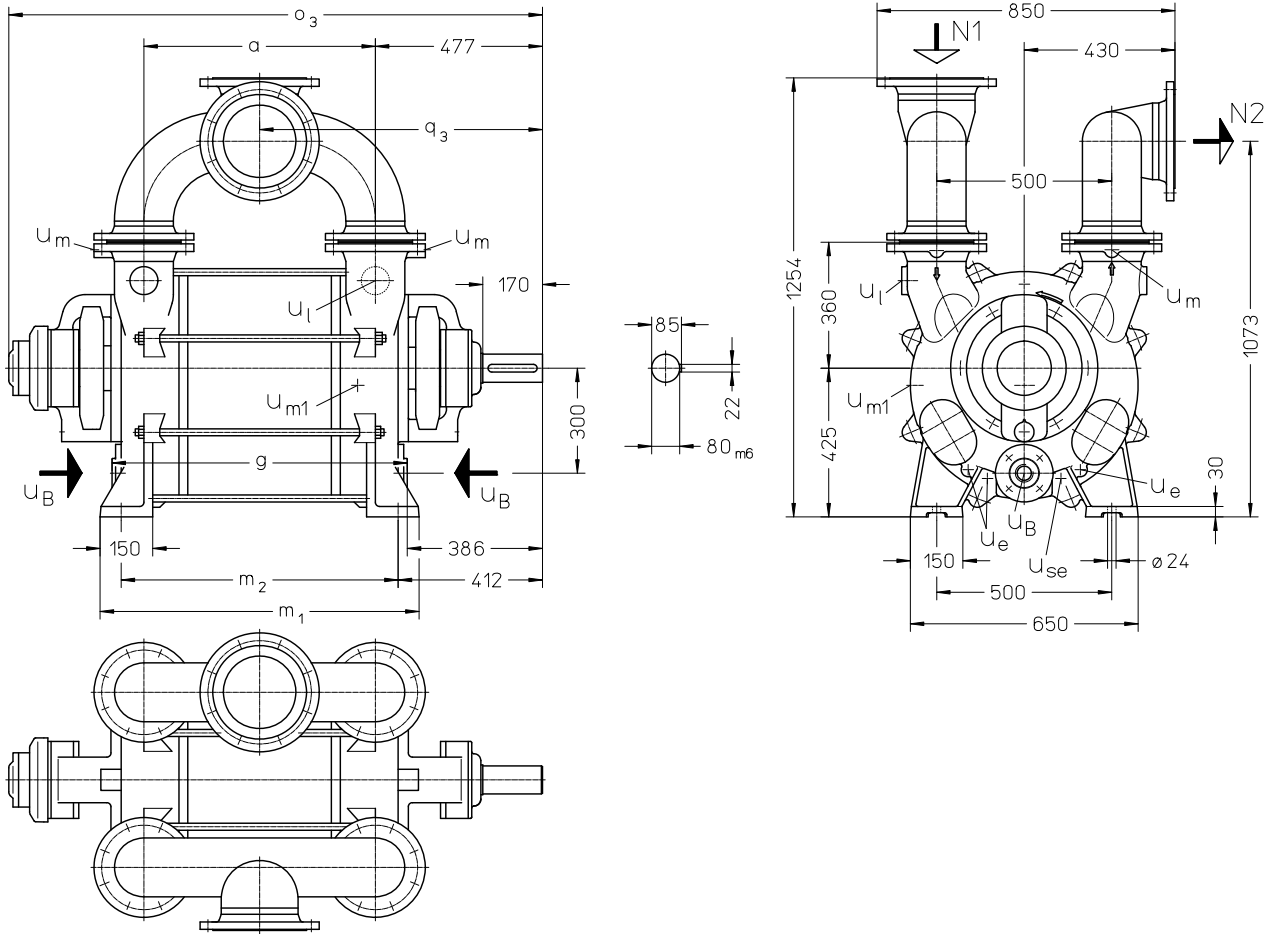

- N 1 = gas inlet DN 200
- N 2 = gas outlet DN 200
- UB = connection for service liquid G 2
- Ue = drain connection G ½
- Ul = connection for vent cock G 1 ½
- Um = connection for pressure gauge G ½
- Um1 = connection for drain valve G ½
- Use = connection for dirt drain G ½

	a	g	m <sub>1</sub>	m <sub>2</sub>	o <sub>3</sub>	q <sub>3</sub>	weight abt. kg
LPH 80540	661	843	911	791	1523	807	1050
LPH 80553	791	973	1041	921	1653	872	1150

flange connections to DIN 2501 PN 10	
DN	200
k	295
D	340
number x d <sub>2</sub>	8 x 22

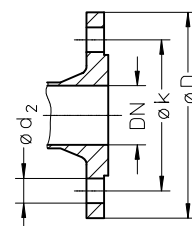

Arrangement drawing LPH 80540, LPH 80553 with upright liquid separator

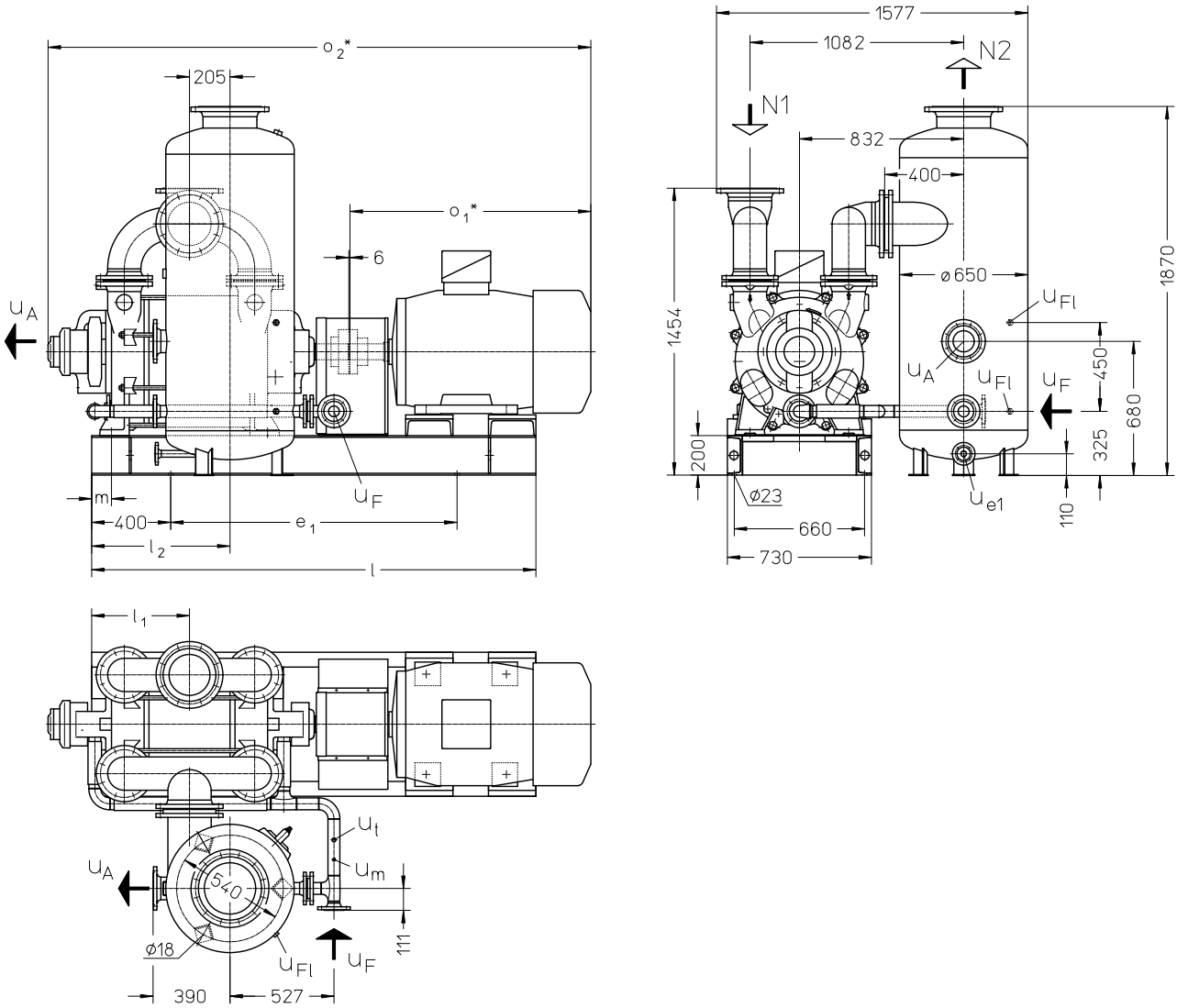

- N 1 = gas inlet DN 200
- N 2 = gas outlet DN 250
- u<sub>A</sub> = connection for liquid drain DN 100
- u<sub>e1</sub> = drain connection DN 25

- u<sub>F</sub> = connection for fresh liquid DN 50
- u<sub>F1</sub> = connection for liquid level indicator G ½
- u<sub>m</sub> = connection for pressure gauge G ¼
- u<sub>t</sub> = connection for thermometer G ½

	electric motor 50 Hz			e <sub>1</sub>	l	l <sub>1</sub>	l <sub>2</sub>	m	o <sub>1</sub> *	o <sub>2</sub> *	weight abt. kg
	size	IP 55	kW EEx e II T3								
LPH 80540	315 S	55	-	1450	2250	495	700	100	1140	2749	2350
	315 M	-	68								
LPH 80553	315 M	75	-	1600	2400	550	755	90	1140	2879	2550
	315 M	-	68								

flange connections to DIN 2501 PN 10					
DN	25	50	100	200	250
k	85	125	180	295	350
D	115	165	220	340	395
number x d <sub>2</sub>	4 x 14	4 x 18	8 x 18	8 x 22	12 x 22

\* dimensions dependent on the motor make

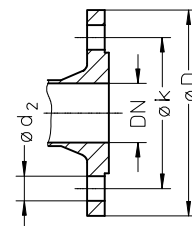

**Fresh water requirement** in [m³/h] dependent on suction pressure, speed, mode of operation and difference in temperature

suction pressure in [mbar]		120				400				600				900							
pump	speed [rpm]	KB				FB	KB				FB	KB				FB					
		difference in temperature [°C]					difference in temperature [°C]					difference in temperature [°C]									
		20	10	5	2		20	10	5	2		20	10	5	2		20	10	5	2	
LPH 80540	585	1,3	2,3	3,7	5,7	9	1,2	2,0	3,1	4,7	7	1,0	1,7	2,5	3,6	5	0,6	0,9	1,3	1,6	2
	735	1,7	2,9	4,4	6,3		1,6	2,6	3,7	5,2		1,3	2,1	3,0	3,9		0,8	1,1	1,4	1,7	
	880	2,1	3,4	4,9	6,8		1,9	3,0	4,2	5,5		1,6	2,5	3,3	4,2		1,0	1,3	1,6	1,8	
LPH 80553	585	1,7	2,8	4,4	6,6	10	1,5	2,5	3,8	5,6	8	1,3	2,1	3,1	4,4	6	0,8	1,2	1,6	2,0	2,5
	735	2,2	3,5	5,2	7,3		2,0	3,2	4,5	6,1		1,7	2,6	3,6	4,8		1,0	1,4	1,8	2,2	
	880	2,6	4,2	5,9	7,8		2,4	3,7	5,1	6,5		2,1	3,1	4,1	5,0		1,3	1,7	2	2,3	

FB = fresh liquid service

KB = combined liquid service with service water 20 °C, 10 °C, 5 °C, 2 °C warmer than the fresh water.

### Data regarding the pump size - order notes

series + size	hydraulics +bearings	shaft sealing	material design	casing seal
	<ul style="list-style-type: none"> <li>• 2 antifriction bearings</li> <li>•N 1 shaft end, clockwise</li> </ul>	041 double gland packing BFG mechanical seal, Burgmann BFK mechanical seal, Burgmann	02 main parts of iron cast, without non-ferrous metal 42 main parts of Cr Ni Mo-cast steel	0 liquid seal
LPH 80540 80553	BN	041, BFG, BFK	02, 42	0

### Design - motor selection table

	designation	electric motor 50 Hz					
		motor enclosure IP 55			motor enclosure EEx e II T3		
		kW	size	designation	kW	size	designation
pump with free shaft end	01						
pump with coupling, pre-drilled at motor side	04						
as above, but with motor, for example 75 kW three-phase motor (50 Hz, 400 VΔ) at 735 rpm	e.g. FD	55 75	315 S 315 M	ED FD	68	315 M	FM

#### Example for ordering:

The construction size LPH 80540 BN 041 02 0 with 75 kW three-phase motor (50 Hz, 400 VΔ) 735 rpm, IP 55 has the complete order number:

**LPH• 80540 BN 041 02 0 FD**

If motors with other voltage or frequency are required a special information should be given.

On delivery the point (•) in the fourth place of the type code is replaced by a letter in the factory.

Any changes in the interest of the technical development are reserved.

#### **Sterling SIHI GmbH**

Lindenstraße 170, D-25524 Itzehoe, Germany, Telephone +49 (0) 48 21 / 7 71 - 01, Fax+49 (0) 48 21 / 7 71 - 274