



# Magna-Tite<sup>®</sup>

The Fastener for  
Thin or Compressible  
Materials



# Huck® Magna-Tite®

## All-Aluminum Fastener Ideal for Thin or Low-Strength Materials

The Huck Magna-Tite® is a specialized aluminum structural rivet fastener well-suited for use within oversized holes and repair applications.

During installation, Magna-Tite clamps the joint with a broad blind-side bulb, making it ideal for installation in thin materials such as aluminum, fiberglass and plastic. Unlike other bulbing blind fasteners, the Magna-Tite has a unique embedded sealant applied between the pin and the sleeve. This sealant oozes into the joint during installation, completely filling any gap, and ensuring water resistance.



**Available Sizes** 3/16", 1/4"

**Materials** Aluminum

**Headstyles** Protruding, Shaveable, Low Profile, 100° Oval Countersunk

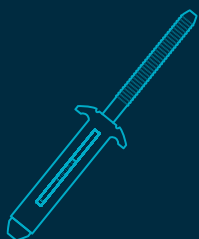

- ✓ Broad blind-side bulbing action prevents pull-through
- ✓ Embedded sealant fills gaps to ensure water resistance
- ✓ Ideal for thin materials like aluminum, fiberglass and plastic
- ✓ Large footprint covers oversize holes
- ✓ Shaveable head styles allow repairs to look similar to OEM installations

## Secure, Fast Installation

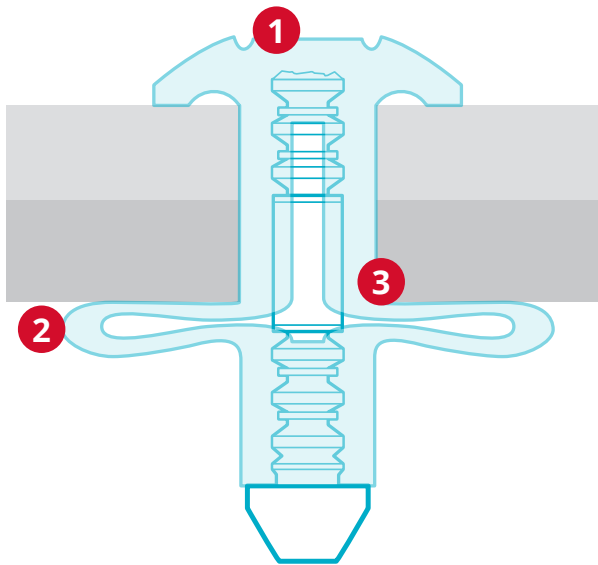

- 1 Shaveable head styles allow similar appearance to OEM rivet installations.
- 2 Large blind-side footprint for installation in thin or compressible materials where controlled strength is required.
- 3 Unique embedded sealant applied between the pin and sleeve.

## Huck® Rivet Shaver 105-MT

The Huck Rivet Shaver tool fits any standard size drill and burnishes 5/32", 3/16" and 1/4" shaveable rivet heads to leave a clean, solid appearance that closely matches solid or brazier head rivets



PART NO.	DESCRIPTION
105-MT	Huck Rivet Shaver + Bit
124351	Huck Rivet Shaver Bit
124486	Huck Rivet Shaver Holder

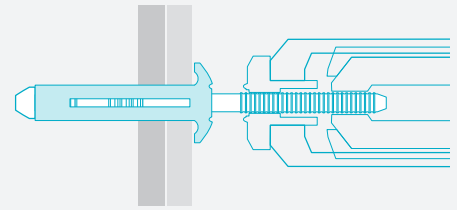

- 1 Insert the fastener into the hole and slip the installation tool over the pintail.

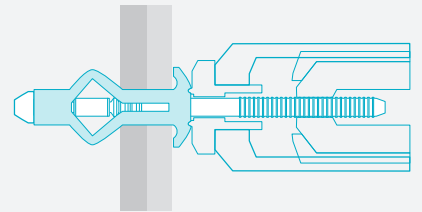

- 2 Press the trigger to initiate pulling action. As the tool pulls on the pintail, the shear ring feature on the pin pulls inside the sleeve fully expanding the diameter and drawing the work pieces together.

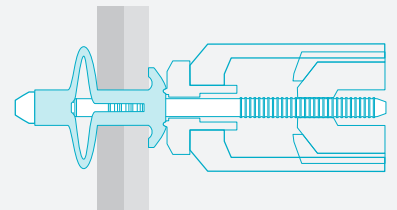

- 3 Continued pulling on the pintail expands the sleeve to maximum allowable diameter. As the shear ring reaches the backside of the work piece it breaks and catches on the tapered annular grooves, keeping high pressure on the blind side of the work pieces as the pin continues to draw down inside the sleeve.

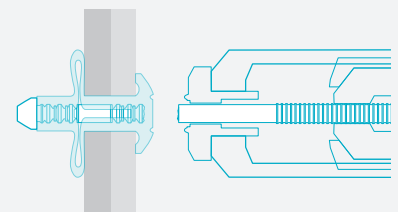

- 4 A solid circle lock between the pin and sleeve is formed just prior to the pin breaking flush with the sleeve head, completing the installation

# Data and Dimensions

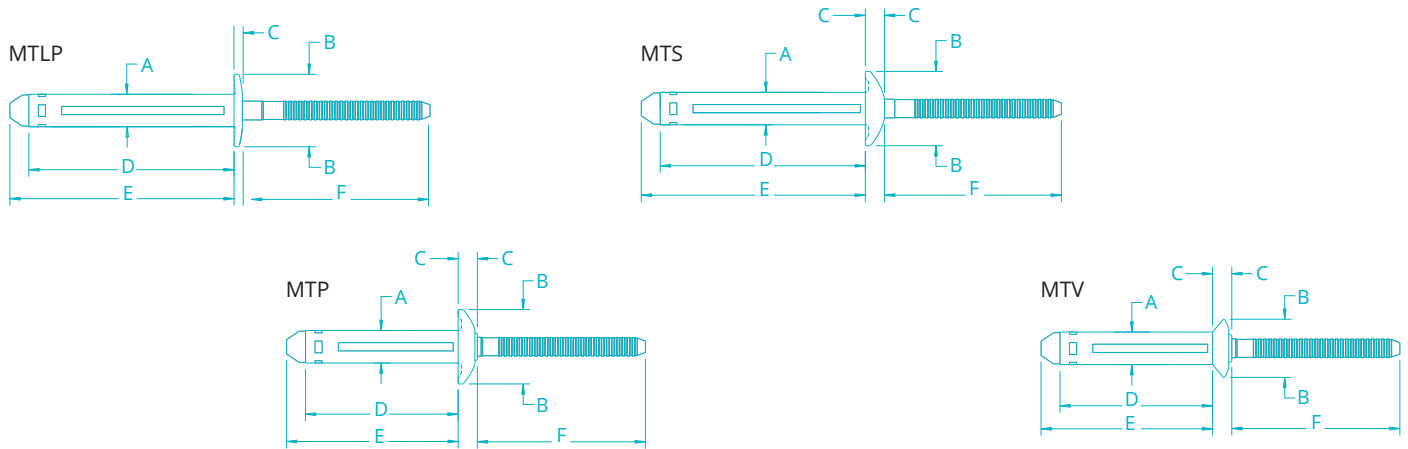

## Magna-Tite Dimensions

DIA.	PART NO.	GRIP RANGE	HOLE SIZE	A NOM	B NOM	C NOM	D MAX	E MAX	F MIN
Protruding Head									
3/16"	MTP-B6-5S	.050 - .312	.205 - .221	.199	.453	.113	.890	1.020	.940
	MTP-B6-6S	.100 - .375	.205 - .221	.199	.453	.113	.940	1.070	.940
	MTP-B6-8S	.250 - .500	.205 - .221	.199	.453	.113	1.090	1.120	.940
	MTP-B6-10S	.375 - .625	.205 - .221	.199	.453	.113	1.215	1.345	.940
	MTP-B6-12S	.500 - .750	.205 - .221	.199	.453	.113	1.340	1.470	.940
8 (1/4")	MTP-B8-4S	.040 - .250	.250 - .263	.239	.530	.120	.825	.990	.950
	MTP-B8-6S	.125 - .375	.250 - .263	.239	.530	.120	.955	1.120	.950
	MTP-B8-7S	.160 - .410	.250 - .263	.239	.530	.120	.985	1.150	.950
	MTP-B8-8S	.250 - .500	.250 - .263	.239	.530	.120	1.075	1.240	.950
	MTP-B8-10S	.375 - .625	.250 - .263	.239	.530	.120	1.200	1.365	.950
	MTP-B8-12S	.500 - .750	.250 - .263	.239	.530	.120	1.325	1.490	.950
Shaveable Head									
6 (3/16")	MTS-B6-8S	.050 - .500	.205 - .221	.199	.453	.113	1.010	1.140	.940
	MTS-B6-12S	.050 - .750	.205 - .221	.199	.453	.113	1.260	1.390	.940
Low Profile (non-structural)									
6 (3/16")	MTLP-B6-4	.050 - .250	.205 - .221	.199	.442	.051	.840	.970	.940
	MTLP-B6-8	.187 - .500	.205 - .221	.199	.442	.051	1.090	1.220	.940
	MTLP-B6-12	.375 - .750	.205 - .221	.199	.442	.051	1.260	1.390	.940
	MTLP-B6-12X	.050 - .750	.205 - .221	.199	.442	.051	1.260	1.390	.940
100° Countersunk Oval Head									
6 (3/16")	MTV-B6-5S	.070 - .312	.205 - .221	.199	.365	.043	.910	1.040	.940
	MTV-B6-7S	.160 - .410	.205 - .221	.199	.365	.043	1.010	1.140	.940
	MTV-B6-8S	.250 - .500	.205 - .221	.199	.365	.043	1.090	1.220	.940
	MTV-B6-10S	.375 - .625	.205 - .221	.199	.365	.043	1.215	1.345	.940
	MTV-B6-12S	.500 - .750	.205 - .221	.199	.365	.043	1.340	1.470	.940

## Installed Values in Nominal Grip (lbs.)

DIA.		HEAD STYLES							
		PROTRUDING		SHAVEABLE		LOW PROFILE		OVAL	
		MIN.	TYP.	MIN.	TYP.	MIN.	TYP.	MIN.	TYP.
3/16"	Shear	550	630	550	630	300*	350	550	630
	Tensile	390	450	390	450	390	450	390	450
	Pin Retention	70	100	70	100	70	100	70	100
1/4"	Shear	950	1100						
	Tensile	575	650						
	Pin Retention	70	100						

\*550 lbs. minimum in minimum grip only

# Ordering Information

Follow the form below to construct a part number for ordering Magna-Tite®.  
Refer to the Grip Tables for grip numbers.

MT(HEAD STYLE) – (MATERIAL) (DIAMETER) — (GRIP NUMBER) (SHAVEABLE OR NOT)

**Example:** MTP-B6-8S is a Protruding Head Magna-Tite, Aluminum, 3/16" Diameter, 8 Grip, Shaveable

HEAD STYLE	PREFIX	MATERIAL	CODE	DIA.	CODE
Protruding Head	P	Aluminum	B	3/16"	6
Shaveable Head	S			1/4"	8
Low Profile	LP			5/16"	10
Countersunk Oval Head	V				

## Materials and Finishes

MATERIAL	SLEEVE	PIN	SLEEVE FINISH	PIN FINISH
Aluminum	5000 Series	7000 Series	Clear Chromate	Clear Chromate



Model  
BV4500-118



Model  
2480

## Advanced Huck® Tooling

Huck offers a choice of hydraulic installation tools designed for the the Magna-Tite. Supporting these tools is Huck's Powerig® 940, a portable hydraulic power source for moderate production and repair applications.

## Installation Tools - Weight and Dimensions

DIA.	MODEL	NOSE ASSEMBLY	INSERT	TYPE	WEIGHT	LENGTH	HEIGHT	WIDTH
3/16"	BV4500-118	99-3487-6MT	126969-Protruding, 126970-Flat*	Battery	5 LBS	14.25"	10.63"	3.75"
	2022	99-3487-6MT		Pneudraulic	5.4 LBS	8.6"	12.6"	4.4"
	2024	99-3487-6MT		Pneudraulic	5.75 LBS	8.9"	12.6"	4.4"
	202	99-3487-6MT		Pneudraulic	5.1 LBS	8.6"	12.5"	4.1"
	2480			Hydraulic	2.2 LBS	8.6"	6.5"	1.9"
1/4"	BV4500-118	99-3487-8MT	126971-Protruding, 126972-Flat*	Battery	5 LBS	14.25"	10.63"	3.75"
	2022	99-3487-8MT		Pneudraulic	5.4 LBS	8.6"	12.6"	4.4"
	2024	99-3487-8MT		Pneudraulic	5.75 LBS	8.9"	12.6"	4.4"
	202	99-3487-8MT		Pneudraulic	5.1 LBS	8.6"	12.5"	4.1"
	2480			Hydraulic	2.2 LBS	8.6"	6.5"	1.9"

\*Insert Included with nose assembly



**HOWMET  
AEROSPACE**

# Howmet Fastening Systems

## Industrial Division Brands



Huck, Marson, Recoil, Keysert, Camloc, Simmonds and Snep are trademarks of Howmet Aerospace Inc. and/or its subsidiaries.

### North America

#### Waco Operations

PO Box 8117  
8001 Imperial Drive  
Waco, TX 76714-8117  
Tel: +1 800-388-4825  
Fax: +1 800-798-4825  
sales.waco@howmet.com

#### Kingston Operations

1 Corporate Drive  
Kingston, NY 12401  
Tel: +1 800-278-4825  
Fax: +1 845-334-7333  
sales.kingston@howmet.com

#### Tracy Operations

1925 North MacArthur Drive  
Tracy, CA 95376  
Tel: +1 800-826-2884  
Fax: +1 800-573-2645  
sales.idg@howmet.com

### Global

#### Telford Operations

Unit C, Stafford Park 7  
Telford, Shropshire  
England TF3 3BQ  
Tel: +44 (0) 1952-290011  
Fax: +44 (0) 1952-290459  
sales.telford@howmet.com

#### Melbourne Operations

1508 Centre Road  
Clayton, Victoria  
Australia 3168  
Tel: +613-8545-3333  
Fax: +613-8545-3390  
sales.melbourne@howmet.com

#### Tokyo Operations (Japan & Korea)

8F CIRCLES Nihonbashi-  
Bakurocho Bldg  
1-5-12 Nihonbashi-Bakurocho  
103-0002 Tokyo Japan  
Tel: +81-3-5642-8360  
Tel: +81-3-5642-8361 x8365  
Fax: +81-3-5644-5772

#### Suzhou Operations

58 Yinsheng Road,  
SIP Suzhou, Jiangsu  
215126 China  
Tel: +86-512-62863800-8888

[hfsindustrial.com](http://hfsindustrial.com)

[YouTube.com/HFSIndustrial](https://www.youtube.com/HFSIndustrial)

The information contained in this publication is only for general guidance, and is not intended to create any warranty, express, implied, or statutory; all warranties are contained only in Howmet Fastening Systems' written quotations, acknowledgments, and/or purchase orders. It is recommended that the user secure specific, up-to-date data and information regarding each application and/or use of such products.