

## CBT 100160...350400

### TECHNICAL DATA

Flow:	max. 2400 m <sup>3</sup> /h
Head:	max. 160 m
Speed:	max. 3000 rpm
Material:	cast iron (0B, 0E) ductile cast iron (1A, 1E) cast steel (2A, 2E) stainless steel (4B) and duplex steel (F1)
Temperature:	max. 200 °C depending on the shaft sealing and material execution.
Casing Pressure:	max. 25 bar
Shaft sealing:	mechanical seal or stuffing box
Flange connections:	material design 0B, 0E DIN 2501 PN 16 1A, 1E DIN 2501 PN 25 2A, 2E, 4B DIN 2501 PN 16 ANSI RF 150 and ANSI RF 300
Direction of rotation:	clockwise when looking at the pump from the drive end.

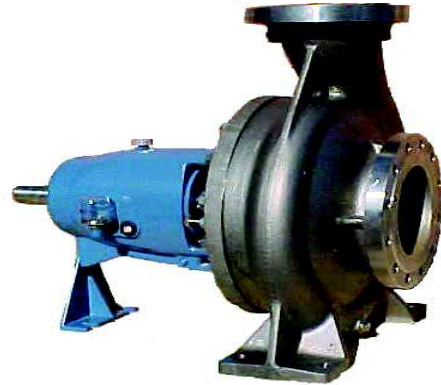

### APPLICATION

Volute casing pumps of the CBT range are used when clear or slightly dirty or even corrosive liquids are to be pumped.

The CBT range pumps are therefore suitable for use in:

- Chemical and petrochemical industries
- Food and beverage industry
- Pharmaceutical industry
- Plastic and rubber industry
- Iron and non-ferrous metal industry
- Paper and pulp industry
- Textile industry
- Thermal power stations
- Water supply
- Irrigation

Particular in applications in:

- All processing plants.
- Pumping of acids, brine and alkalis and all types of hydrocarbons.
- Surface treatment and surfacing hardening of metal, e. g. galvanizing, anodizing, phosphatising.
- Desalination and extractions plants.
- Heating engineering for circulation of water and other heat transfer fluids.
- Water treatment and supply.
- Treatment of industrial effluents.
- A range of materials is available to meet the specific needs of customers.

### DESIGN

Horizontal, single-stage volute casing pumps with design features and nominal rating to ISO 2858 / EN 22858.

The design of the pump allows the complete drive unit to be withdrawn from the casing without disturbing the attached pipe work. If a spacer type coupling is used, it is also unnecessary to disconnect the motor.

The range covers 21 sizes with only 4 different bearing brackets.

### CONSTRUCTION

#### Sizes with single volute casing:

100160, 125200, 150200, 150315, 150400, 150500, 200250, 200315, 250315.

#### Sizes with double volute casing:

200400, 200500, 250300, 250400, 250500, 250550, 250630, 300400, 300500, 350400.

#### Sizes with single volute casing with diffuser:

150630, 200630

### Casing pressure:

Temperature range	Material execution		
	EN-JL 1040	EN-JS 1025	Stainless steel
-20 °C to +120 °C	16 bar	25 bar	16 bar
+120 °C to +200 °C	13 bar	16 bar	10 bar

Max. casing pressure= inlet pressure + delivery head at zero flow

Max. test pressure= EN-JS 1025 33 bar; EN-JL 1040 and stainless steel 21 bar

**Please note:** The relevant technical regulations and safety rules must be observed.

### Flanges location:

Axial suction flange, discharge flange radially upwards.

### Flanges:

Material design Stainless steel: Complies with DIN 2543 PN 16

Material design EN-JL 1040: DIN 2533 PN 16

Material design EN-JS 1025: DIN 2534 PN 25

Flanges drilled according to ANSI can be supplied

### Bearings:

One deep groove ball bearing on the pump side, two single-row angular contact ball bearings in an O arrangement on the drive end. Oil lubrication, desing code R.

- Oil level control by constant level oiler as standard.
- Bearing brackets are optional equipped with tapped holes for installation of temperature/vibration sensors.

### Shaft sealing (Stuffing box and mechanical seal)

Code 041: Self-sealed, uncooled packing rings

Code BK3: Unbalanced bellows mechanical seal, seal face materials Graphite/ SiC, elastomer EPDM

Code BKS: Unbalanced bellows mechanical seal, seal face materials SiC/ SiC, elastomer FPM (Viton)

Code X0D: Balanced mechanical seal, cartridge seal face materials SiC/ SiC - Carbon/ SiC elastomer FPM (Viton)

Code X0M: Balanced mechanical seal, cartridge seal face materials Carbon/ SiC - Carbon/ SiC elastomer FPM (Viton)

According to EN 12756, it is possible the installation of double mechanical seal mounted back-to-back or tandem arrangement.

On all versions the seal cover plates can be provided with a hole for draining the leakage and with a quench connection incorporating a throttling bush.

Other sealing execution can be supplied on request.

**Material design:**

Item	Component	Material				Construction								
		Mat. N°	DIN denomination	ISO EN denomination	US Material		0B	0E	1A	1E	2A	2E	4B	F1
					ASTM Standard	AISI								
10.20	Volute casing	EN-JL 1040 1.4408 EN-JS1025 1.0619 1.4517	GG-25 GX6CrNiMo18 10 GGG-40.3 GS-C 25 GX3CrNiMoCuN26 6 3 3	EN-GJL 250 GX5CrNiMo19-11-2 EN-GJS-400-18-LT GP 240 GH GX3CrNiMoCuN26 6 3 3	A 278 Cl. 30 A 351 CF8M A 395 A 216 Gr WCB	316	x	x	x	x	x	x	x	x
16.10	Casing cover	EN-JL 1040 1.4408 EN-JS1025 1.0619 1.4517	GG-25 GX6CrNiMo18 10 GGG-40.3 GS-C 25 GX3CrNiMoCuN26 6 3 3	EN-GJL 250 GX5CrNiMo19-11-2 EN-GJS-400-18-LT GP 240 GH GX3CrNiMoCuN26 6 3 3	A 278 Cl. 30 A 351 CF8M A 395 A 216 Gr WCB	316	x	x	x	x	x	x	x	x
21.00	Shaft	1.0503 1.4462	C 45 X2CrNiMoN 22 5 3	C 45 X2CrNiMoN 22 5 3	A 576 Gr1045	1045	x	x	x	x	x	x	x	x
23.00	Impeller	EN-JL 1040 1.4408 1.4517	GG-25 GX6CrNiMo18 10 GX3CrNiMoCuN26 6 3 3	EN-GJL 250 GX5CrNiMo19-11-2 GX3CrNiMoCuN26 6 3 3	A 278 Cl. 30 A 351 CF8M	316	x	x	x	x	x	x	x	x
50.20	Wear ring	EN-JL 1040 1.4408 1.4517	GG-25 GX6CrNiMo18 10 GX3CrNiMoCuN26 6 3 3	EN-GJL 250 GX5CrNiMo19-11-2 GX3CrNiMoCuN26 6 3 3	A 278 Cl. 30 A 351 CF8M	316	x	x	x	x	x	x	x	x
33.00	Bearing bracket	EN-JL 1040	GG-25	EN-GJL 250	A 278 Cl. 30		x	x	x	x	x	x	x	x
52.30	Shaft sleeve / Mechanical seal	1.4571 1.4462	X6CrNiMoTi 17 12 2	X6CrNiMoTi 17 12 2	A 276 Gr316Ti	316Ti	x	x	x	x	x	x	x	x
52.40	Shaft sleeve / Stuffing box	1.4122 1.4571 1.4462	X35CrMo 17 X6CrNiMoTi 17 12 2 X2CrNiMoN 22 5 3	X39CrMo 17 1 X6CrNiMoTi 17 12 2 X2CrNiMoN 22 5 3	A 276 Gr316Ti	316Ti	x	x	x	x	x	x	x	x
46.10	Shaft seal / Stuffing box	Soft packing						x	x	x	x	x	x	x
43.30	Mechanical seal	Silicon Carbide / Carbon EPDM or Viton ( See other options )						x	x	x	x	x	x	x

**Casing gasket:**

The casing is sealed by flat gasket of PTFE GF 25 material. Code of this design: 2

Only for pump size 150630, 200630 and 250630 the casing is sealed by O-ring Viton. Code of this design: V

Only for pump size 150630, 200630 and 250630 the casing is sealed by O-ring EPDM. Code of this design: E

**Motor Power:**

Using commercial electric motors, type of construction IM B3.

To determine the drive power we recommend the following safety margin:

Up to 4 kW: 25%

4 to 7,5 kW: 20%

above 7,5 kW: 15%

The following speeds must not be exceeded:

size	max. speed rpm	size	max. speed rpm	size	max. speed rpm
100160	3000	125200	1800	150500	1500
		150200		250400	
		150315		250500	
		154000		250550	
		200250		200500	
		200630		300400	
		200315		250300	
		250315	350400		

The max. speeds are derived from the permissible shaft loads and the permissible peripheral speeds of the impellers

**Bearing bracket / pump size:**

Bracket 45B	100160 125200 150200
Bracket 55	150315 150400 150500 200250 200315 200400 200500 250300 250315
Bracket 65	150630 250400 250500 250550 300400 300500 350400
Bracket 75	200630 250630

**General comments:**

Regarding horizontal single stage volute pumps as per dimensions ISO 2858 / EN 22858 and meeting the technical requirements of ISO 5199 / EN 25199, we refer to standard chemical pumps program of the **SIHI<sup>isochem</sup>**.

**SECTIONAL DRAWING AND NOMENCLATURE**

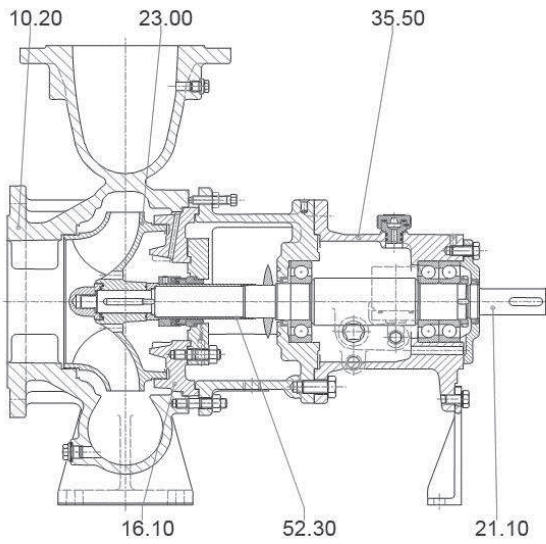

**Single volute casing pumps; bearing bracket 45 B**

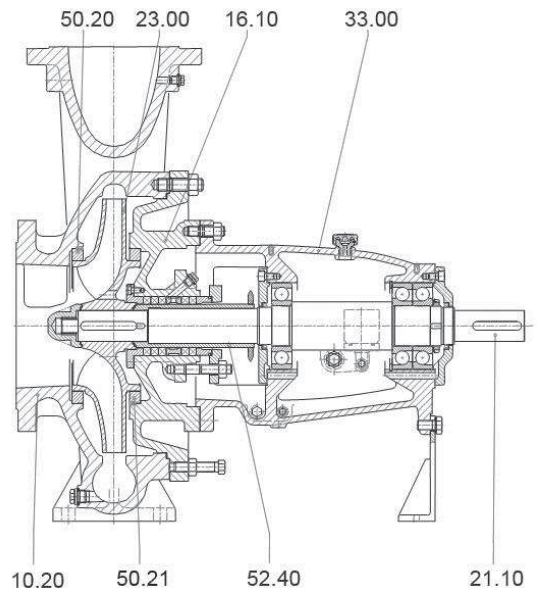

**Single volute casing pumps; bearing bracket 55**

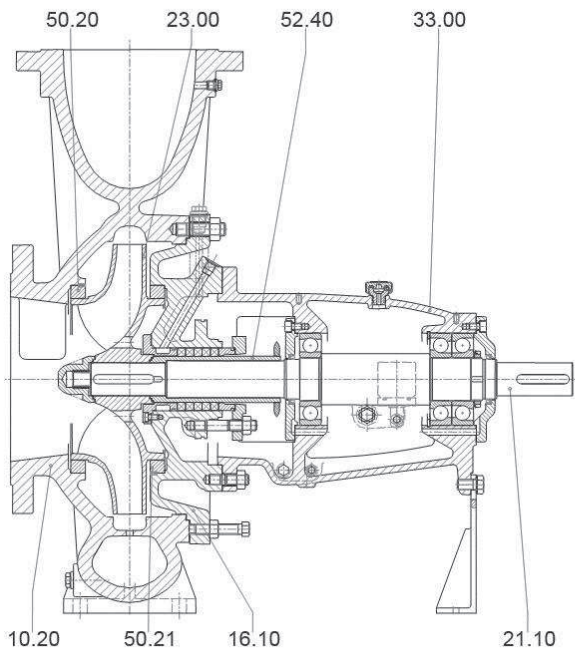

**Double volute casing pumps**

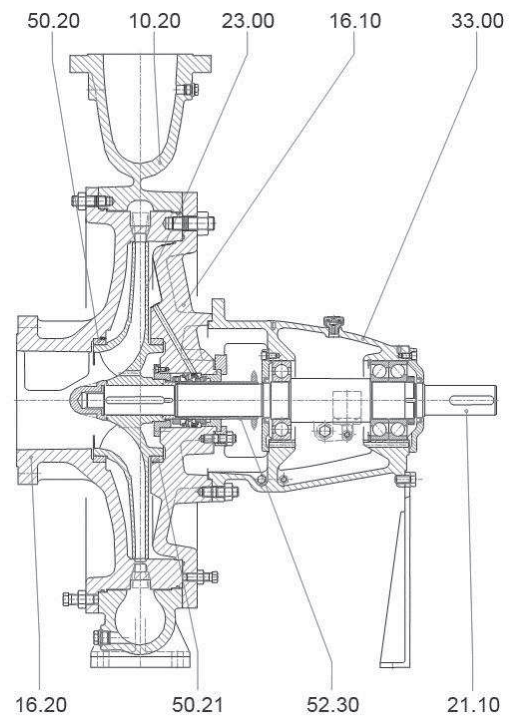

**Pumps with diffuser**

10.20	volute casing	33.00, 35.50	bearing bracket
16.10, 16.20	casing cover	50.20, 50.21	wear ring
21.00	shaft	52.30	shaft sleeve (mechanical seal)
23.00	impeller	52.40	shaft sleeve (stuffing box)

**Performance Graph**

n = 1480 1/min.  
 n = \* 2900 1/min.

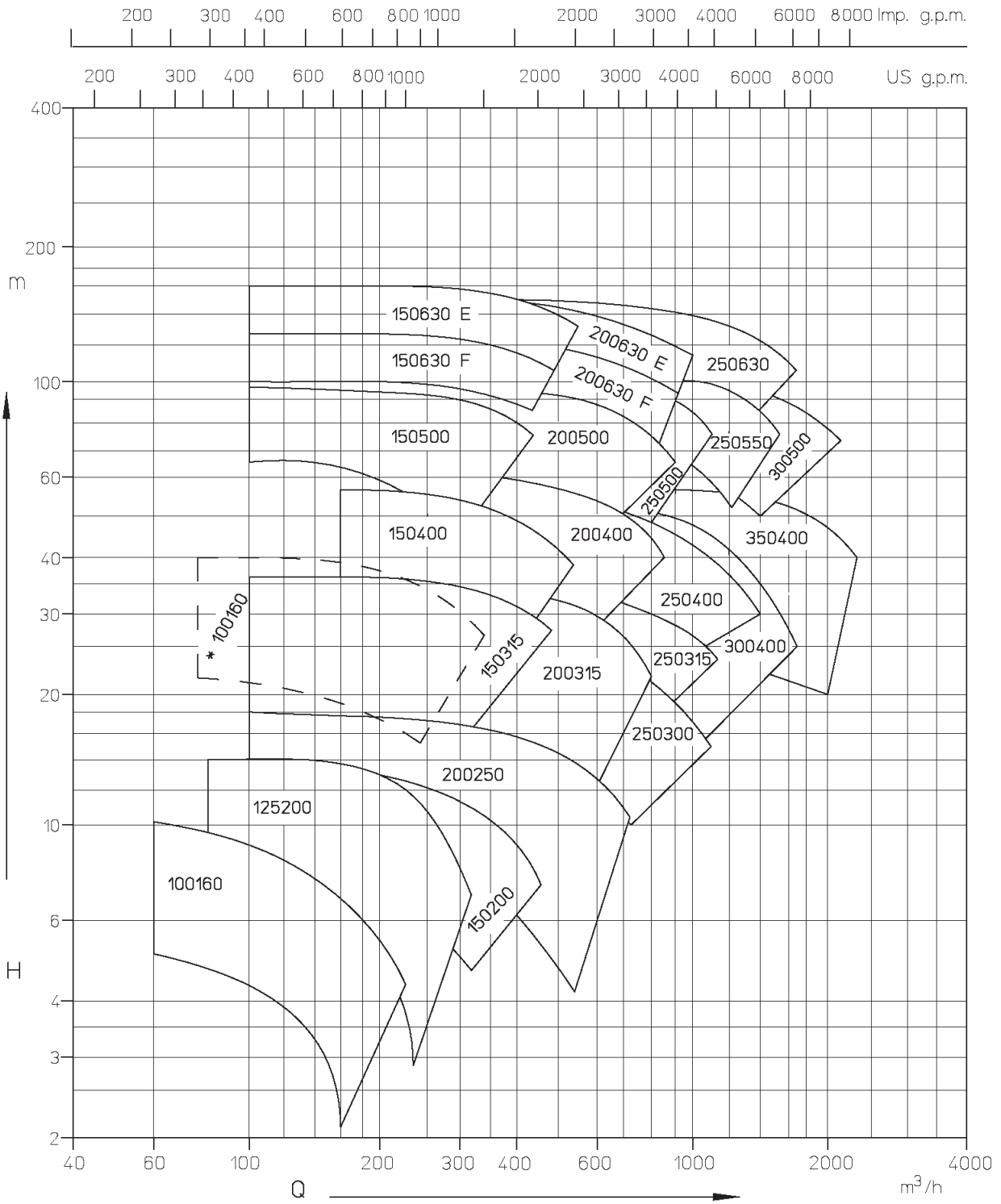

## Table of Dimensions

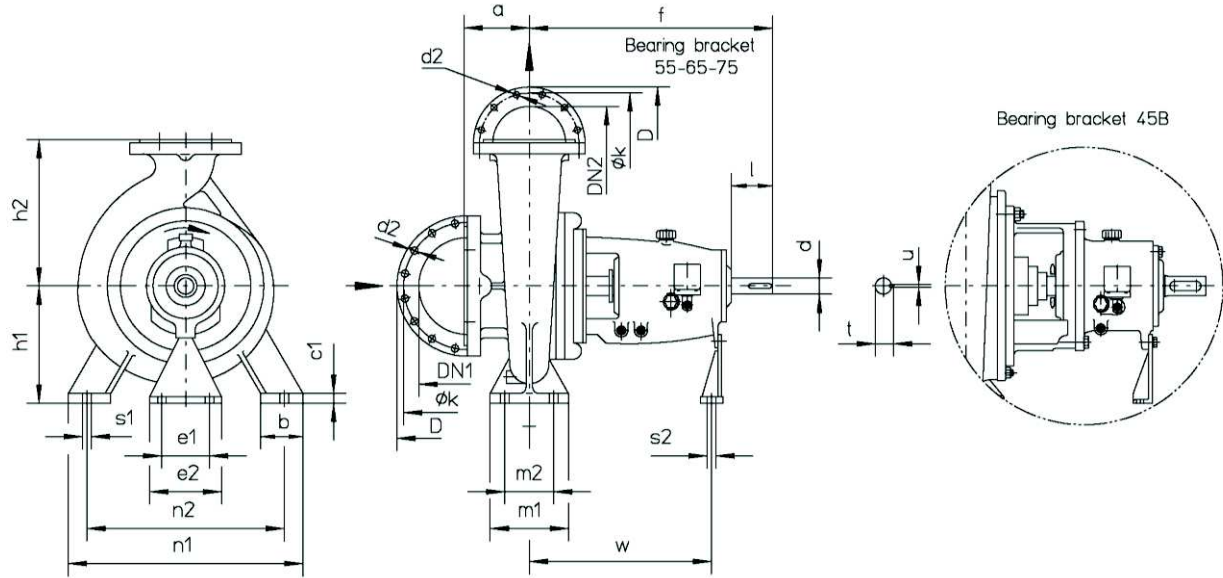

All dimensions in mm

Size	BB	Pump dimensions										Foot dimensions						Shaft end				
		DN2	DN1	a	f	h1	h2	b	c1	m1	m2	n1	n2	s1*	s2*	e1	e2	w	d	l	t	u
100160	45B	100	125	125	527,5	200	280	80	18	160	120	360	280	M16	M12	110	140	400,5	32	80	35	10
125200	45B	125	150	140	500	250	315	80	18	160	120	400	315	M16	M12	110	140	370	32	80	35	10
150200	45B	150	200	160	500	280	400	100	20	200	150	550	450	M20	M12	110	140	370	32	80	35	10
150315	55	150	200	160	670	315	400	100	22	200	150	550	450	M20	M16	140	200	489	50	110	53.5	14
150400	55	150	200	160	670	315	450	100	22	200	150	550	450	M20	M16	140	200	489	50	110	53.5	14
150500	55	150	200	180	670	400	500	100	22	200	150	640	540	M20	M16	140	200	489	50	110	53.5	14
150630	65	150	200	250	720	540	700	160	30	200	150	1000	880	M20	M16	140	200	508	60	140	64	18
200250	55	200	200	180	720	355	425	100	22	200	150	550	450	M20	M16	140	200	539	50	110	53.5	14
200315	55	200	250	200	670	355	450	100	22	200	150	550	450	M20	M16	140	200	489	50	110	53.5	14
200400	55	200	250	180	670	355	500	100	22	200	150	550	450	M20	M16	140	200	489	50	110	53.5	14
200500 <sup>1)</sup>	55	200	250	200	670	425	560	100	22	200	150	660	560	M20	M16	140	200	489	50	110	53.5	14
200630	75	200	250	250	760	600	750	160	30	200	150	1100	980	M20	M16	140	200	518	75	170	80	22
250300	55	250	300	305	655	425	550	120	28	240	190	700	600	M20	M16	140	200	474	50	110	53.5	14
250315	55	250	300	250	670	375	560	120	28	240	190	620	520	M20	M16	140	200	489	50	110	53.5	14
250400	65	250	300	250	720	400	600	120	29	240	190	700	600	M20	M16	140	200	508	60	140	64	18
250500	65	250	300	250	720	450	670	120	32	240	190	750	650	M20	M16	140	200	508	60	140	64	18
250550	65	250	300	250	720	480	700	120	32	240	190	750	650	M20	M16	140	200	508	60	140	64	18
250630	75	250	300	250	760	560	750	160	35	260	200	1050	950	M24	M16	140	200	518	75	170	80	22
300400	65	300	350	300	720	425	670	120	30	250	190	760	660	M24	M16	140	200	508	60	140	64	18
300500	65	300	350	300	720	480	670	140	32	250	190	840	720	M24	M16	140	200	508	60	140	64	18
350400	65	350	400	300	715	525	700	140	30	300	220	900	800	M24	M16	140	200	508	60	140	64	18

<sup>1)</sup> Discharge flange 12 x threaded drillings/M20 (only for PN 16 flanges).

\* Slots suitable for bolts with dimensions indicated. Bolts are not included in the bare shaft pump standard scope of supply.

Flange connections to DIN 2501 PN 16									Flange connections to DIN 2501 PN 25							
DN <sub>2</sub> /DN <sub>1</sub>	100	125	150	200	250	300	350	400	100	125	150	200	250	300	350	400
D	220	250	285	340	405	460	520	580	235	270	300	360	425	485	555	620
k	180	210	240	295	355	410	470	525	190	220	250	310	370	430	490	550
d <sub>2</sub> x	18x8	18x8	22x8	22x12	26x12	26x12	26x16	30x16	22x8	26x8	26x8	26x12	30x12	30x16	33x16	36x16



## Table of connections

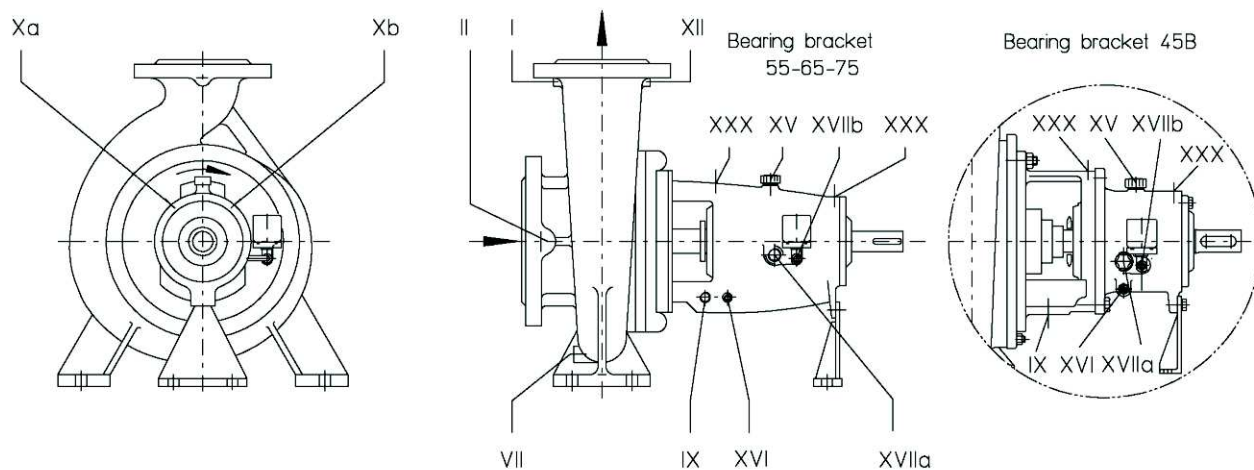

Pos.	Connections	Bearing bracket			
		45 B	55	65	75
I	Pressure gauge	G 1/4" <sup>1)</sup>	G 1/2" <sup>1)</sup>	G 1/2" <sup>1)</sup>	G 1/2" <sup>1)</sup>
II	Pressure/vacuum gauge	G 1/4" <sup>1)</sup>	G 1/2" <sup>1)</sup>	G 1/2" <sup>1)</sup>	G 1/2" <sup>1)</sup>
VII	Drain	G 3/8"	G 1/2" "	G 1/2" <sup>2)</sup>	G 3/4"
IX	Leakage liquid connection	G 1/2"	G 1/2" "	G 1/2" "	G 1/2" "
Xa	Sealing liquid - inlet	G 1/4" <sup>4)</sup>	G 1/4" <sup>4)</sup>	G 1/4" <sup>4)</sup>	G 1/4" <sup>4)</sup>
Xb	Sealing liquid - outlet	G 1/4" <sup>4)</sup>	G 1/4" <sup>4)</sup>	G 1/4" <sup>4)</sup>	G 1/4" <sup>4)</sup>
XII	External circulation	G 1/4"	G 1/4"	G 1/4" <sup>3)</sup>	G 1/2"
XV	Oil filling	Ø 20	Ø 20	Ø 20	Ø 20
XVI	Oil draining	G 1/4"	G 1/4"	G 1/4"	G 1/4"
XVIIa	Oil level sight glass	G 3/4"	G 3/4"	G 3/4"	G 3/4"
XVIIb	Constant level oiler	G 1/4"	G 1/4"	G 1/4"	G 1/4"
XXX	Sensor connection	M 8	M 8	M 8	M 8

- 1) On request
- 2) For sizes 150630 and 350400 – G3/4"
- 3) For sizes 150630 and 350400 – G1/2"
- 4) Depending of the shaft seal arrangement

# Foundation plan for units with spacer type coupling, CBTA bearing bracket 45B

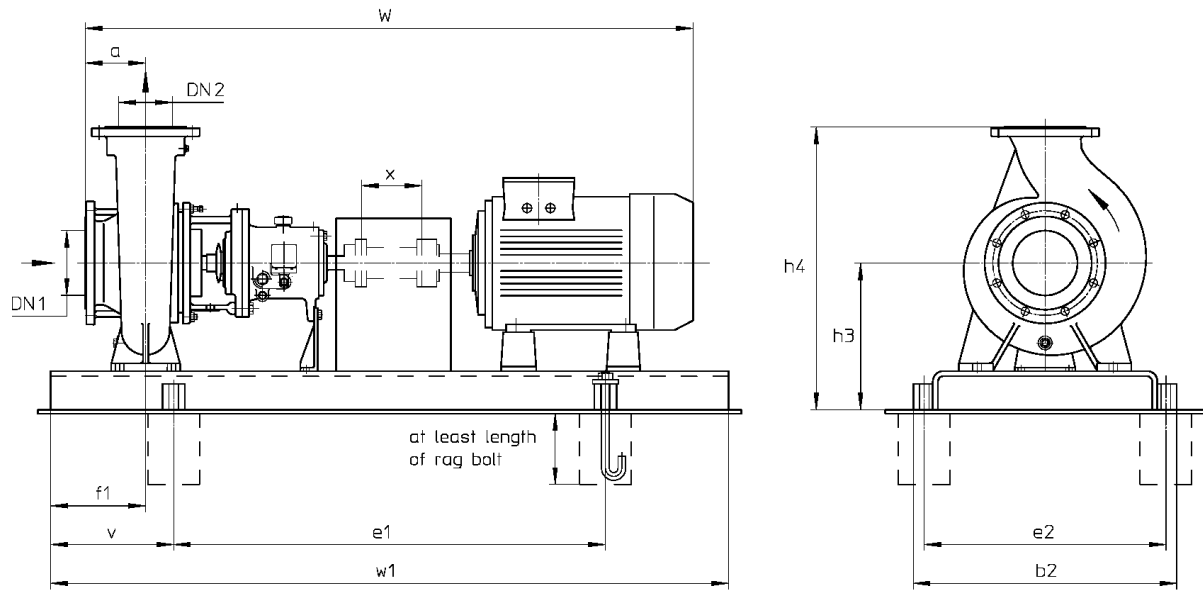

Dimensions in mm  
Tolerances for welded parts acc. to DIN 8570 B

CBTA size	motor rpm		size	Base plate No.	cplg.	weight (kg)		DN <sub>2</sub>	DN <sub>1</sub>	a	b <sub>2</sub>	v	e <sub>1</sub>	e <sub>2</sub>	f <sub>1</sub>	h <sub>3</sub>	h <sub>4</sub>	x	W*	W <sub>1</sub>	rag bolt size
	1450 KW	2900 KW				pump	Unit*														
100160	2.20	-	100L	S385	H 95	96	196	100	125	125	490	200	740	440	90	280	560	140	1137	1140	M20x250
	3.00	-	100L	S385	H 95	96	200	100	125	125	490	200	740	440	90	280	560	140	1137	1140	M20x250
	4.00	-	112M	S385	H 95	96	208	100	125	125	490	200	740	440	90	280	560	140	1158	1140	M20x250
	5.50	-	132S	S385	H 95	96	218	100	125	125	490	200	740	440	90	280	560	140	1218	1140	M20x250
	-	15.00	160M	S487	H110	96	312	100	125	125	610	240	940	550	90	300	580	140	1353	1420	M24x400
	-	18.50	160L	S487	H110	96	322	100	125	125	610	240	940	550	90	300	580	140	1353	1420	M24x400
	-	22.00	180M	S487	H125	96	355	100	125	125	610	240	940	550	90	300	580	140	1435	1420	M24x400
	-	30.00	200L	S487	H125	96	415	100	125	125	610	240	940	550	90	300	580	140	1485	1420	M24x400
	-	37.00	200L	S487	H125	96	435	100	125	125	610	240	940	550	90	300	580	140	1485	1420	M24x400
125200	5.50	-	132S	S486	H 95	123	267	125	150	140	610	205	840	550	90	350	665	140	1234	1250	M24x400
	7.50	-	132M	S486	H 95	123	274	125	150	140	610	205	840	550	90	350	665	140	1234	1250	M24x400
	11.00	-	160M	S487	H 95	123	332	125	150	140	610	240	940	550	90	350	665	140	1368	1420	M24x400
	15.00	-	160L	S487	H110	123	348	125	150	140	610	240	940	550	90	350	665	140	1368	1420	M24x400
	18.50	-	180M	S487	H110	123	374	125	150	140	610	240	940	550	90	350	665	140	1450	1420	M24x400
150200	5.50	-	132S	S607	H 95	153	335	150	200	160	730	230	940	670	110	380	780	140	1254	1400	M24x400
	7.50	-	132M	S607	H 95	153	342	150	200	160	730	230	940	670	110	380	780	140	1254	1400	M24x400
	11.00	-	160M	S607	H 95	153	380	150	200	160	730	230	940	670	110	380	780	140	1388	1400	M24x400
	15.00	-	160L	S607	H110	153	396	150	200	160	730	230	940	670	110	380	780	140	1388	1400	M24x400
	18.50	-	180M	S607	H110	153	422	150	200	160	730	230	940	670	110	380	780	140	1470	1400	M24x400

\* Dimension w and weight unit depend on the motor manufacturer.

Foundation plan for units with spacer type coupling, CBTA bearing brackets 55, 65 and 75

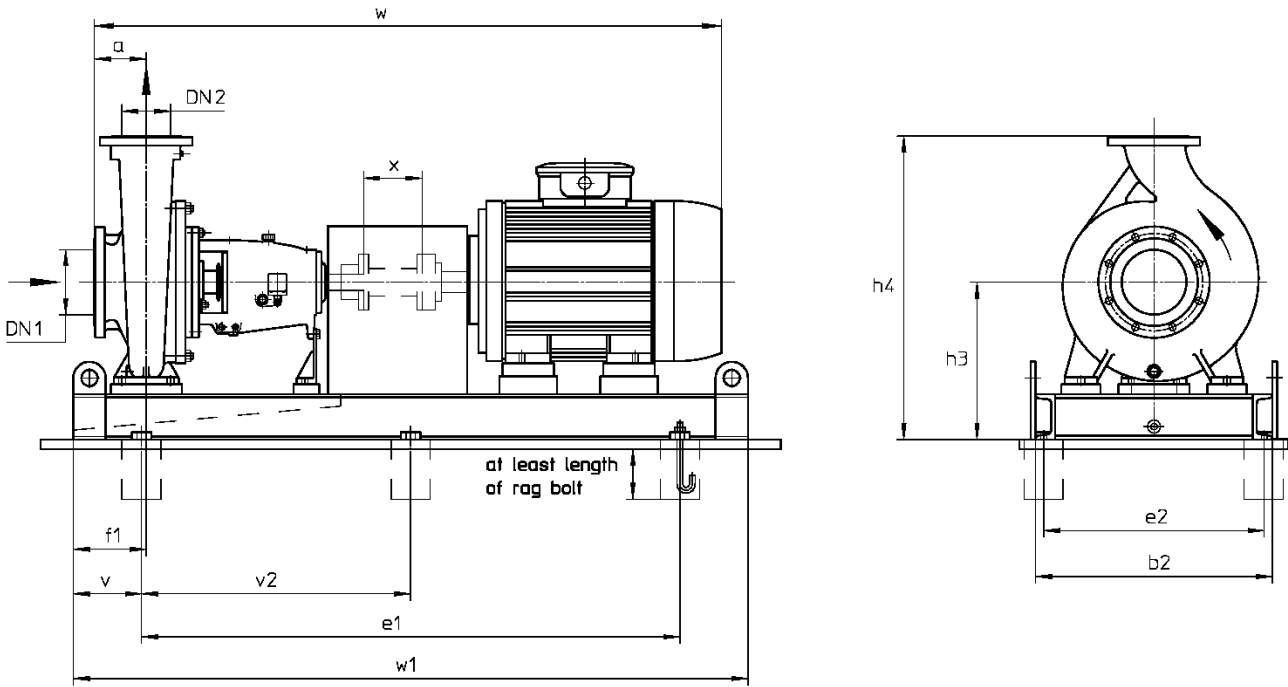

Dimensions in mm

Tolerances for welded parts acc. to DIN 8570 B

$n = 1450 \text{ rpm}$

CBTA size	motor kW	motor size	base plate No.	cplg.	weight pump kg	weight unit* kg	DN <sub>2</sub>	DN <sub>1</sub>	a	b <sub>2</sub>	v	e <sub>1</sub>	e <sub>2</sub>	v <sub>2</sub>	f <sub>1</sub>	h <sub>3</sub>	h <sub>4</sub>	x	w*	w <sub>1</sub>	rag bolt
150315	22.00	180L	180x73x14	H125	280	695	150	200	160	730	190	1420	680	710	200	485	885	180	1680	1800	M16x200
	30.00	200L	194x73x14	H125	280	750	150	200	160	730	190	1560	680	780	200	485	885	180	1730	1940	M16x200
	37.00	225S	196x73x14	H140	280	800	150	200	160	730	190	1580	680	790	200	485	885	180	1800	1960	M16x200
	45.00	225M	196x73x14	H140	280	840	150	200	160	730	190	1580	680	790	200	485	885	180	1800	1960	M16x200
	55.00	250M	208x73x14	H160	280	930	150	200	160	730	210	1660	680	830	200	485	885	180	1900	2080	M16x200
150400	45.00	225M	196x73x14	H140	310	870	150	200	160	730	190	1580	680	790	200	485	935	180	1800	1960	M16x200
	55.00	250M	208x73x14	H160	310	960	150	200	160	730	210	1660	680	830	200	485	935	180	1900	2080	M16x200
	75.00	280S	215x74x14	H180	310	1115	150	200	160	740	210	1730	690	865	200	485	935	180	1970	2150	M16x200
	90.00	280M	215x74x14	H180	310	1160	150	200	160	740	210	1730	690	865	200	485	935	180	1970	2150	M16x200
150500	55.00	250M	208x82x14	H160	350	1005	150	200	180	820	210	1660	770	830	240	570	1070	180	1920	2080	M16x200
	75.00	280S	215x82x14	H180	350	1165	150	200	180	820	210	1730	770	865	240	570	1070	180	1990	2150	M16x200
	90.00	280M	215x82x14	H180	350	1210	150	200	180	820	210	1730	770	865	240	570	1070	180	1990	2150	M16x200
	110	315S	230x83x16	H200	350	1395	150	200	180	830	230	1840	770	920	245	590	1090	180	2132	2300	M18x300
	132	315M	230x83x16	H200	350	1475	150	200	180	830	230	1840	770	920	245	590	1090	180	2132	2300	M18x300
150630	110	315S	255x120x18	H200	860	2085	150	200	250	1200	250	1900	1140	950	310	750	1450	180	2252	2400	M18x300
	132	315M	255x120x18	H200	860	2165	150	200	250	1200	250	1900	1140	950	310	750	1450	180	2252	2400	M18x300
	160	315L	255x120x18	H200	860	2315	150	200	250	1200	250	2050	1140	1025	310	750	1450	180	2412	2550	M18x300
	200	315L	255x120x18	H200	860	2420	150	200	250	1200	250	2050	1140	1025	310	750	1450	180	2412	2550	M18x300
	250	315	**	**	**	**	**	**	**	**	**	**	**	**	**	**	**	**	**	**	**
200250	15.00	160L	180x73x12	H125	300	650	200	200	180	730	190	1420	680	710	240	495	920	180	1668	1800	M16x200
	18.50	180M	186x73x12	H125	300	680	200	200	180	730	190	1480	680	740	240	495	920	180	1750	1860	M16x200
	22.00	180L	186x73x12	H125	300	700	200	200	180	730	190	1480	680	740	240	495	920	180	1750	1860	M16x200
	30.00	200L	194x73x14	H125	300	770	200	200	180	730	190	1560	680	780	240	515	940	180	1800	1940	M16x200
	30.00	200L	194x73x14	H125	310	780	200	250	200	730	190	1560	680	780	260	525	975	180	1820	1940	M16x200
200315	37.00	225S	198x73x14	H140	310	835	200	250	200	730	190	1600	680	800	260	525	975	180	1857	1980	M16x200
	45.00	225M	198x73x14	H140	310	870	200	250	200	730	190	1600	680	800	260	525	975	180	1857	1980	M16x200
	55.00	250M	210x73x14	H160	310	965	200	250	200	730	210	1680	680	840	260	525	975	180	1980	2100	M16x200
	75.00	280S	217x74x14	H180	310	1100	200	250	200	740	210	1750	690	875	260	525	975	180	2055	2170	M16x200
	45.00	225M	196x73x14	H140	350	910	200	250	180	730	190	1580	680	790	260	525	1025	180	1820	1960	M16x200
200400	55.00	250M	208x73x14	H160	350	1005	200	250	180	730	210	1660	680	830	260	525	1025	180	1920	2080	M16x200
	75.00	280S	215x74x14	H180	350	1150	200	250	180	740	210	1730	690	865	260	525	1025	180	1990	2150	M16x200
	90.00	280M	215x74x14	H180	350	1195	200	250	180	740	210	1730	690	865	260	525	1025	180	1990	2150	M16x200
	110	315S	230x82x16	H200	350	1405	200	250	180	820	230	1840	760	920	260	545	1045	180	2150	2300	M18x300
	132	315M	230x82x16	H200	350	1485	200	250	180	820	230	1840	760	920	260	545	1045	180	2150	2300	M18x300
200500	75.00	280S	217x84x14	H180	400	1200	200	250	200	840	210	1750	790	875	260	595	1155	180	2010	2170	M16x200
	90.00	280M	217x84x14	H180	400	1245	200	250	200	840	210	1750	790	875	260	595	1155	180	2010	2170	M16x200
	110	315S	246x85x16	H200	400	1475	200	250	200	850	230	1860	790	930	265	615	1175	180	2152	2320	M18x300
	132	315M	246x85x16	H200	400	1555	200	250	200	850	230	1860	790	930	265	615	1175	180	2152	2320	M18x300
	160	315L	246x85x16	H200	400	1705	200	250	200	850	250	1960	790	980	265	615	1175	180	2312	2460	M18x300
	200	315L	246x85x16	H200	400	1810	200	250	200	850	250	1960	790	980	265	615	1175	180	2312	2460	M18x300
200630	160	315L	260x131x20	H200	900	2470	200	250	250	1310	270	2060	1240	1030	315	830	1580	180	2452	2600	M20x400
	200	315L	260x131x20	H200	900	2570	200	250	250	1310	270	2060	1240	1030	315	830	1580	180	2452	2600	M20x400
	250	315	**	**	**	**	**	**	**	**	**	**	**	**	**	**	**	**	**	**	**
	315	315	**	**	**	**	**	**	**	**	**	**	**	**	**	**	**	**	**	**	**
	355	355	**	**	**	**	**	**	**	**	**	**	**	**	**	**	**	**	**	**	**
400	355	**	**	**	**	**	**	**	**	**	**	**	**	**	**	**	**	**	**	**	



CBTA size	motor		base plate No.	cplg.	weight kg		DN <sub>2</sub>	DN <sub>1</sub>	a	b <sub>2</sub>	v	e <sub>1</sub>	e <sub>2</sub>	v <sub>2</sub>	f <sub>1</sub>	h <sub>3</sub>	h <sub>4</sub>	x	w*	w <sub>1</sub>	rag bolt
	kW	size			pump	unit*															
250300	37.00	225S	207x88x14	H140	416	898	250	300	305	880	210	1650	830	825	365	595	1145	180	1947	2070	M16x200
	45.00	225M	207x88x14	H140	416	928	250	300	305	880	210	1650	830	825	365	595	1145	180	1947	2070	M16x200
	55.00	250M	219x88x14	H160	416	1044	250	300	305	880	210	1770	830	885	365	595	1145	180	2070	2190	M16x200
	75.00	280S	226x88x14	H180	416	1225	250	300	305	880	230	1800	830	900	365	595	1145	180	2145	2260	M16x200
250315	45.00	225M	203x80x14	H140	425	980	250	300	250	800	210	1610	750	805	310	545	1105	180	1890	2030	M16x200
	55.00	250M	215x80x14	H160	425	1070	250	300	250	800	210	1730	750	865	310	545	1105	180	1990	2150	M16x200
	75.00	280S	222x80x14	H180	425	1240	250	300	250	800	230	1760	750	880	310	545	1105	180	2060	2220	M16x200
	90.00	280M	222x80x14	H180	425	1285	250	300	250	800	230	1760	750	880	310	545	1105	180	2060	2220	M16x200
	110	315S	237x82x16	H200	425	1485	250	300	250	820	230	1910	760	955	315	565	1125	180	2202	2370	M18x300
250400	45.00	225M	208x88x14	H140	465	1020	250	300	250	880	210	1660	830	830	310	570	1170	180	1940	2080	M16x200
	55.00	250M	220x88x14	H160	465	1130	250	300	250	880	230	1740	830	870	310	570	1170	180	2040	2200	M16x200
	75.00	280S	227x88x14	H180	465	1285	250	300	250	880	230	1810	830	905	310	570	1170	180	2110	2270	M16x200
	90.00	280M	227x88x14	H180	465	1330	250	300	250	880	230	1810	830	905	310	570	1170	180	2110	2270	M16x200
	110	315S	256x89x16	H200	465	1565	250	300	250	890	250	1920	830	960	315	590	1190	180	2252	2420	M18x300
	132	315M	256x89x16	H200	465	1645	250	300	250	890	250	1920	830	960	315	590	1190	180	2252	2420	M18x300
	160	315L	256x89x16	H200	465	1740	250	300	250	890	250	2060	830	1030	315	590	1190	180	2412	2560	M18x300
250500	75.00	280S	227x93x14	H180	590	1415	250	300	250	930	230	1810	880	905	310	620	1290	180	2110	2270	M16x200
	90.00	280M	227x93x14	H180	590	1460	250	300	250	930	230	1810	880	905	310	620	1290	180	2110	2270	M16x200
	110	315S	256x94x16	H200	590	1705	250	300	250	940	250	1920	880	960	315	640	1310	180	2252	2420	M18x300
	132	315M	256x94x16	H200	590	1785	250	300	250	940	250	1920	880	960	315	640	1310	180	2252	2420	M18x300
	160	315L	256x94x16	H200	590	1935	250	300	250	940	250	2060	880	1030	315	640	1310	180	2412	2560	M18x300
250550	75.00	280S	227x93x14	H180	660	1485	250	300	250	930	230	1810	880	905	310	650	1350	180	2110	2270	M16x200
	90.00	280M	227x93x14	H180	660	1530	250	300	250	930	230	1810	880	905	310	650	1350	180	2110	2270	M16x200
	110	315S	256x94x16	H200	660	1775	250	300	250	940	250	1920	880	960	315	670	1370	180	2252	2420	M18x300
	132	315M	256x94x16	H200	660	1855	250	300	250	940	250	1920	880	960	315	670	1370	180	2252	2420	M18x300
	160	315L	256x94x16	H200	660	2005	250	300	250	940	250	2060	880	1030	315	670	1370	180	2412	2560	M18x300
250630	200	315L	262x127x22	H200	965	2675	250	300	250	1270	270	2080	1200	1040	315	810	1560	180	2452	2620	M20x400
	250	315																			
	315	315																			
	355	355	**	**	**	**	**	**	**	**	**	**	**	**	**	**	**	**	**	**	**
	400	355	**	**	**	**	**	**	**	**	**	**	**	**	**	**	**	**	**	**	**
	500	355	**	**	**	**	**	**	**	**	**	**	**	**	**	**	**	**	**	**	**
	560	400	**	**	**	**	**	**	**	**	**	**	**	**	**	**	**	**	**	**	**
630	400	**	**	**	**	**	**	**	**	**	**	**	**	**	**	**	**	**	**	**	
300400	75.00	280S	232x94x14	H180	620	1440	300	350	300	940	230	1860	890	930	360	595	1265	180	2160	2320	M16x200
	90.00	280M	232x94x14	H180	620	1485	300	350	300	940	230	1860	890	930	360	595	1265	180	2160	2320	M16x200
	110	315S	261x95x16	H200	620	1720	300	350	300	950	250	1970	890	985	365	615	1285	180	2302	2470	M18x300
	132	315M	261x95x16	H200	620	1800	300	350	300	950	250	1970	890	985	365	615	1285	180	2302	2470	M18x300
	160	315L	261x95x16	H200	620	1950	300	350	300	950	270	2070	890	1035	365	615	1285	180	2462	2610	M18x300
	200	315L	261x95x16	H200	620	2055	300	350	300	950	270	2070	890	1035	365	615	1285	180	2462	2610	M18x300
	250	315	**	**	**	**	**	**	**	**	**	**	**	**	**	**	**	**	**	**	**
315	315	**	**	**	**	**	**	**	**	**	**	**	**	**	**	**	**	**	**	**	
300500	110	315S	261x103x16	H200	805	1955	300	350	300	1030	250	1970	970	985	365	670	1340	180	2302	2470	M18x300
	132	315M	261x103x16	H200	805	2035	300	350	300	1030	250	1970	970	985	365	670	1340	180	2302	2470	M18x300
	160	315L	261x103x16	H200	805	2185	300	350	300	1030	270	2070	970	1035	365	670	1340	180	2462	2610	M18x300
	200	315L	261x103x16	H200	805	2290	300	350	300	1030	270	2070	970	1035	365	670	1340	180	2462	2610	M18x300
	250	315	**	**	**	**	**	**	**	**	**	**	**	**	**	**	**	**	**	**	**
	355	355	**	**	**	**	**	**	**	**	**	**	**	**	**	**	**	**	**	**	**
	400	355	**	**	**	**	**	**	**	**	**	**	**	**	**	**	**	**	**	**	**
500	355	**	**	**	**	**	**	**	**	**	**	**	**	**	**	**	**	**	**	**	
350400	132	315M	260x110x18	H200	865	2235	350	400	300	1100	250	1950	1040	970	365	735	1435	180	2297	2450	M18x300
	160	315L	260x110x18	H200	865	2285	350	400	300	1100	270	2060	1040	1030	365	735	1435	180	2457	2600	M18x300
	200	315L	260x110x18	H200	865	2390	350	400	300	1100	270	2060	1040	1030	365	735	1435	180	2457	2600	M18x300
	250	315	**	**	**	**	**	**	**	**	**	**	**	**	**	**	**	**	**	**	**
315	315	**	**	**	**	**	**	**	**	**	**	**	**	**	**	**	**	**	**	**	

\* Dimension w and weight unit depend on the motor manufacturer.

\*\* On request.

Data regarding size - order information

Type	Size	Hydraulic + Bearing	Shaft Seal	Material	Casing Gasket	Lubrication	Flange
		<p>A• First hydraulic</p> <p>D• Double volute</p> <p>E• Fourth hydraulic with diffuser type E</p> <p>F• Fifth hydraulic with diffuser type F</p> <p>•R One deep groove ball bearing on the pump side, two single-row angular contact ball bearings on the drive end. Oil lubrication</p>	<p>041: Self-sealed, uncooled packing rings</p> <p>BK3: Unbalanced bellows mechanical seal, seal face materials Graphite/ SiC, elastomer EPDM</p> <p>BKS: Unbalanced bellows, mechanical seal, seal face materials SiC/ SiC, elastomer FPM (Viton)</p> <p>X0D: Balanced mechanical seal, cartridge seal face materials SiC/ SiC - Carbon/ SiC elastomer FPM (Viton)</p> <p>X0M: Balanced mechanical seal, cartridge seal face materials Carbon/ SiC - Carbon/ SiC elastomer FPM (Viton)</p>	<p>0B: Cast iron GG25</p> <p>0E: Cast iron GG25 stainless steel 1.4408 impeller</p> <p>1A: Ductile cast iron GGG40.3 cast iron GG25 impeller</p> <p>1E: Ductile cast iron GGG40.3 stainless steel 1.4408 impeller</p> <p>2A: Cast steel GSC25 cast iron GG25 impeller</p> <p>2E: Cast steel GSC25 stainless steel 1.4408 impeller</p> <p>4B: Stainless steel 1.4408</p> <p>F1: Duplex steel 1.4517 with 1.4462 shaft</p>	<p>V: O-rings Viton</p> <p>E: O-rings EPDM</p> <p>2: Flat gasket of PTFE GF</p>	<p>A: Constant level oiler</p>	<p>0: Flange to DIN PN16</p> <p>1: Flange to DIN PN25</p> <p>3: Flange drilled to ANSI RF150</p> <p>5: Flange drilled to ANSI RF300</p>
CBTA	100160	AR			2		
	125200						
	150200						
	150315						
	150400						
	150500						
	150630	ER, FR			V,E		
CBTE	200250	AR	Alternatively 041, BK3, BKS, X0D, X0M	Alternatively 0B, 0E, 1A, 1E, 2A, 2E  4B, F1	2	A	Alternatively 0, 1, 3, 5
	200315	AR					
	200400	DR					
	200500	DR					
	200630	ER, FR					
	250300	DR					
CBTA	250315	AR					
	250400	DR					
	250500						
	250550						
	250630						
	300400						
	300500						
	350400						
						V,E	
					2		

**Sterling SIHI (Spain), S.A.**  
Vereda de los Zapateros s/n, Pozuelo de Alarcón 28223 Madrid, Spain.  
Telephone +34 91 709 1310 Telefax +34 91 715 9700  
[www.sihi.com](http://www.sihi.com)