

Precision Diffuser Technology

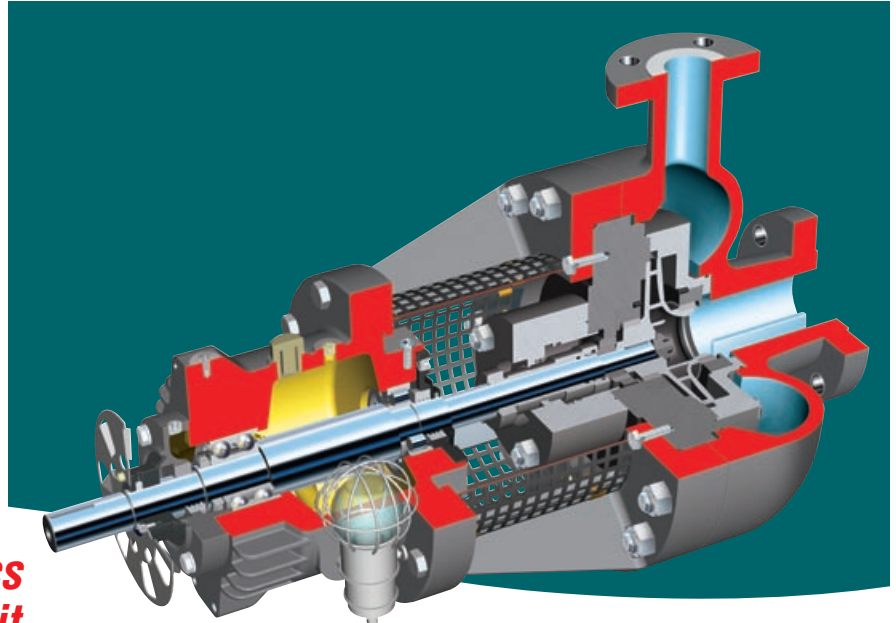
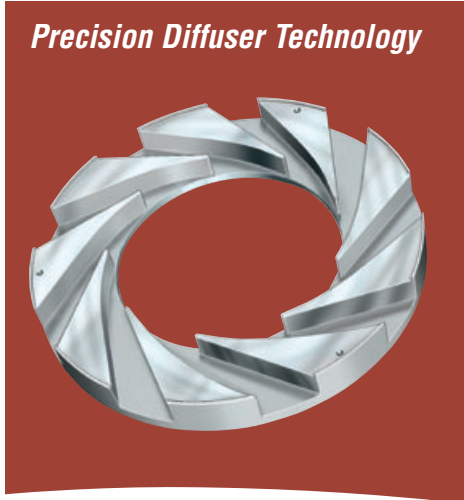

Custom-Tuned Hydraulics Ensure Best Efficiency Fit

Fully compliant with ISO 13709/API 610 (OH2), latest edition, the PHL process pump offers exceptional customization. Its innovative multi-channel diffuser technology allows the pump hydraulics to be custom tuned to ensure best efficiency hydraulic fits while maximizing parts interchangeability. In fact, this versatile and highly engineered pump boasts more than 170 hydraulic configurations supported by only four shaft and two bearing housing designs.

In addition to custom hydraulics, the PHL's state-of-the-art diffuser technology results in extremely low total cost of ownership. This is due to:

- Long mean time between failures (MTBF) and low maintenance cost
- Low seal emission and long mechanical seal life
- Low vibration and noise levels
- High efficiency for low energy consumption
- Low NPSH

Flowserve has been recognized for these benefits by Dow Chemical with its Energy Award.

Broad Application

- Oil production and transportation
- Hydrocarbon processing
- Petrochemical processing
- General industry

Features and Benefits

Multi-Channel Diffuser Technology permits hydraulic customization for optimal performance and efficiency while minimizing radial loads at all flows. Diffusers are replaceable, providing users flexibility in addressing changing operating parameters.

ISO 21049/API 682 Seal Chamber accommodates a variety of seal types, including dual pressurized, unpressurized and gas, for the most severe applications.

End or Top Suction Nozzle Orientation is available to suit site piping systems.

Air Fan or Water Jacketed Cooling of bearings allows operating temperatures up to 450°C (840°F).

Available Boron Diffusion Surface Treatment offers increased abrasion resistance for applications containing fines or particulates.

Performance Advantages

- Diffuser tuning maximizes pump efficiency, widens operational flow window and minimizes radial hydraulic thrust at all flows
- Diffuser design permits 10 to 20% of BEP minimum continuous flow, compared to 20 to 35% for volute pump design
- Low shaft vibration results in longer L10h bearing life
- Low shaft deflection assures optimal mechanical seal
- Low noise level (at least 3 dB(A) below volute pump designs) helps reduce plant sound levels

Operating Parameters

- Flows from 2.5 m³/h (11 gpm) to 900 m³/h (4000 gpm)
- Heads to 400 m (1300 ft)
- Pressures to 40 bar (600 psi)
- Temperatures to 200°C (392°F); 450°C (840°F) with air fan or water jacketed cooling of bearings

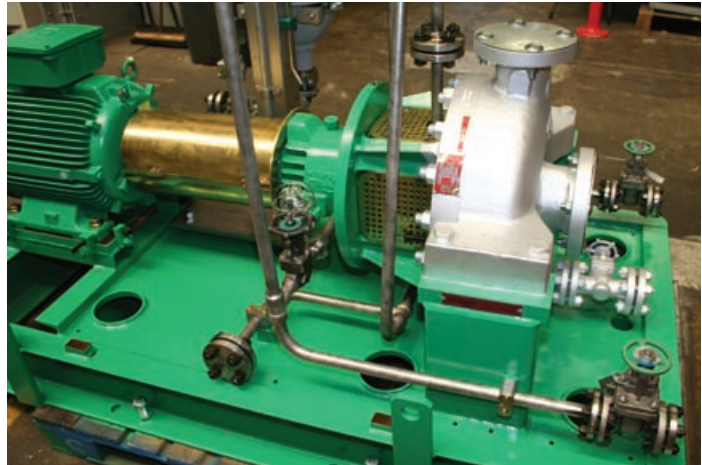

PHL Range Chart

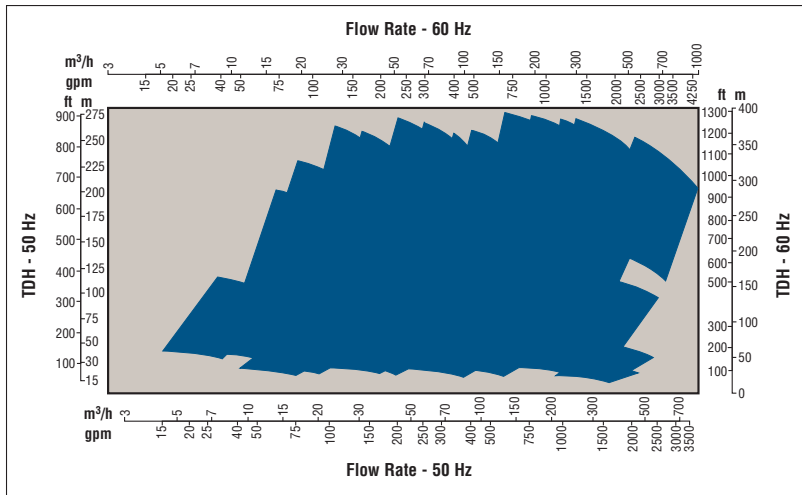

Complementary Pump Designs

PHL pumps may be used with other Flowserve design pumps, including:

- PVML ISO 13709/API 610 (OH5) vertical in-line, diffuser style process pump
- PVXM ISO 13709/API 610 (OH3) vertical in-line, diffuser style process pump
- HPX ISO 13709/API 610 (OH2) overhung, end suction, volute style process pump
- ERPN overhung, end suction, volute style process pump

Bulletin PSS-10-5.2c (E) Printed in USA. February 2010.
 © Flowserve Corporation

To find your local Flowserve representative:

For more information about Flowserve Corporation, visit www.flowserve.com or call USA 1 800 728 PUMP (7867)

USA and Canada
 Flowserve Corporation
 5215 North O'Connor Blvd.
 Suite 2300
 Irving, Texas 75039-5421 USA
 Telephone: 1 937 890 5839

Europe, Middle East, Africa
 Flowserve Corporation
 Gebouw Hagepoint
 Westbroek 39-51
 4822 ZX Breda
 Netherlands
 Telephone: 31 76 502 8920

Latin America
 Flowserve Corporation
 Boulevard del Cafetal
 Edificio Ninina, Local 7
 El Cafetal - Caracas
 Venezuela 1061
 Telephone: 58 212 985 3092
 Telefax: 58 212 985 1007

Asia Pacific
 Flowserve Pte. Ltd.
 10 Tuas Loop
 Singapore 637345
 Telephone: 65 6771 0600
 Telefax: 65 6779 4607

Precision Diffuser Technology

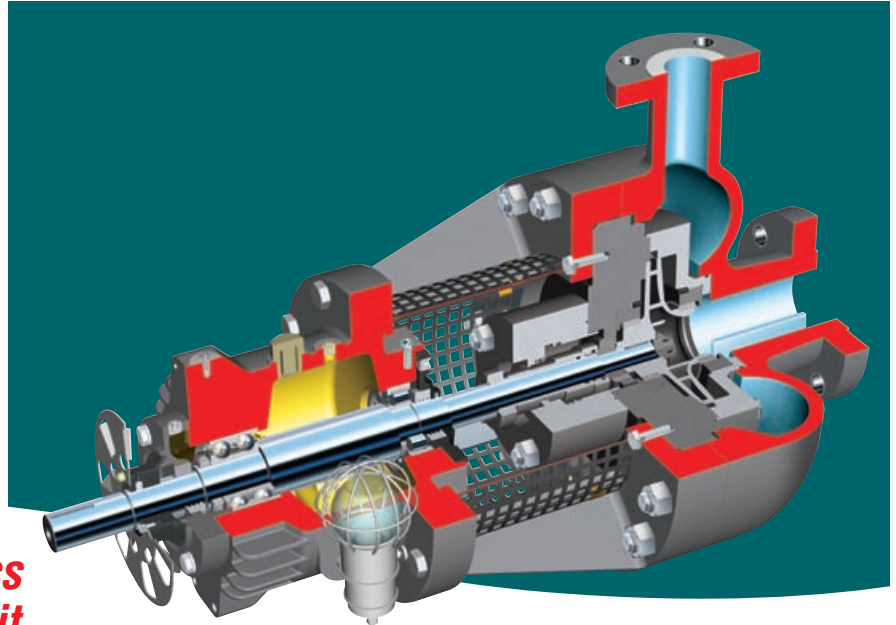
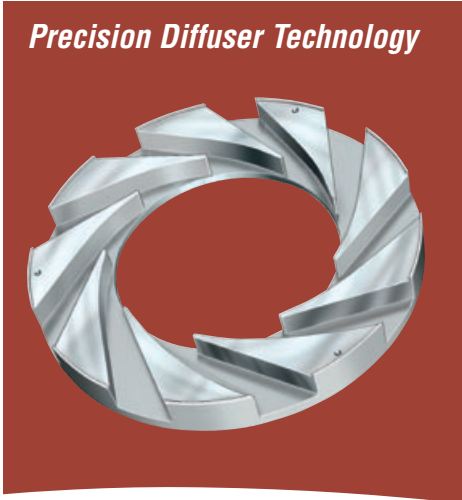

Custom-Tuned Hydraulics Ensure Best Efficiency Fit

Fully compliant with ISO 13709/API 610 (OH2), latest edition, the PHL process pump offers exceptional customization. Its innovative multi-channel diffuser technology allows the pump hydraulics to be custom tuned to ensure best efficiency hydraulic fits while maximizing parts interchangeability. In fact, this versatile and highly engineered pump boasts more than 170 hydraulic configurations supported by only four shaft and two bearing housing designs.

In addition to custom hydraulics, the PHL's state-of-the-art diffuser technology results in extremely low total cost of ownership. This is due to:

- Long mean time between failures (MTBF) and low maintenance cost
- Low seal emission and long mechanical seal life
- Low vibration and noise levels
- High efficiency for low energy consumption
- Low NPSH

Flowserve has been recognized for these benefits by Dow Chemical with its Energy Award.

Broad Application

- Oil production and transportation
- Hydrocarbon processing
- Petrochemical processing
- General industry

Features and Benefits

Multi-Channel Diffuser Technology permits hydraulic customization for optimal performance and efficiency while minimizing radial loads at all flows. Diffusers are replaceable, providing users flexibility in addressing changing operating parameters.

ISO 21049/API 682 Seal Chamber accommodates a variety of seal types, including dual pressurized, unpressurized and gas, for the most severe applications.

End or Top Suction Nozzle Orientation is available to suit site piping systems.

Air Fan or Water Jacketed Cooling of bearings allows operating temperatures up to 450°C (840°F).

Available Boron Diffusion Surface Treatment offers increased abrasion resistance for applications containing fines or particulates.

Performance Advantages

- Diffuser tuning maximizes pump efficiency, widens operational flow window and minimizes radial hydraulic thrust at all flows
- Diffuser design permits 10 to 20% of BEP minimum continuous flow, compared to 20 to 35% for volute pump design
- Low shaft vibration results in longer L10h bearing life
- Low shaft deflection assures optimal mechanical seal
- Low noise level (at least 3 dB(A) below volute pump designs) helps reduce plant sound levels

Operating Parameters

- Flows from 2.5 m³/h (11 gpm) to 900 m³/h (4000 gpm)
- Heads to 400 m (1300 ft)
- Pressures to 40 bar (600 psi)
- Temperatures to 200°C (392°F); 450°C (840°F) with air fan or water jacketed cooling of bearings

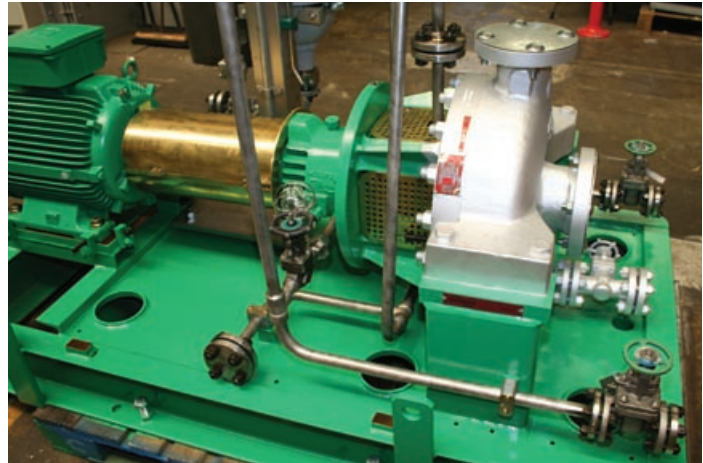

PHL Range Chart

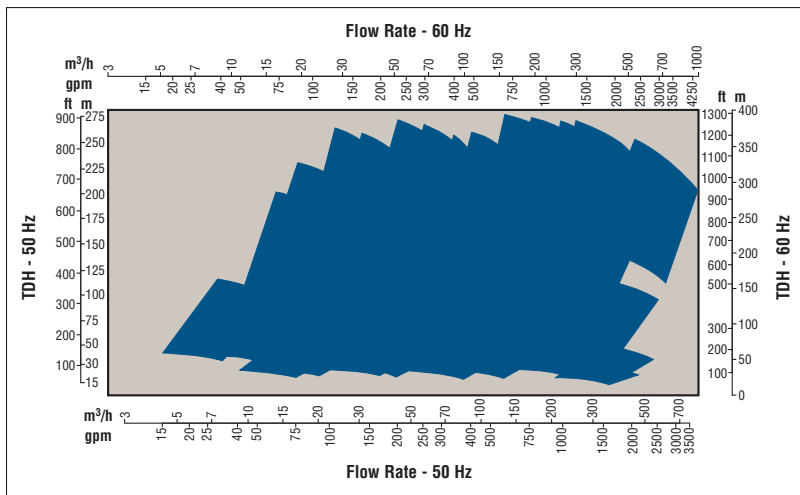

Complementary Pump Designs

PHL pumps may be used with other Flowserve design pumps, including:

- PVML ISO 13709/API 610 (OH5) vertical in-line, diffuser style process pump
- PVXM ISO 13709/API 610 (OH3) vertical in-line, diffuser style process pump
- HPX ISO 13709/API 610 (OH2) overhung, end suction, volute style process pump
- ERPN overhung, end suction, volute style process pump

Bulletin PSS-10-5.2c (E/A4) Printed in USA. February 2010.
 © Flowserve Corporation

To find your local Flowserve representative:

For more information about Flowserve Corporation, visit www.flowserve.com or call USA 1 800 728 PUMP (7867)

USA and Canada

Flowserve Corporation
 5215 North O'Connor Blvd.
 Suite 2300
 Irving, Texas 75039-5421 USA
 Telephone: 1 937 890 5839

Europe, Middle East, Africa

Flowserve Corporation
 Gebouw Hagepoint
 Westbroek 39-51
 4822 ZX Breda
 Netherlands
 Telephone: 31 76 502 8920

Latin America

Flowserve Corporation
 Boulevard del Cafetal
 Edificio Ninina, Local 7
 El Cafetal - Caracas
 Venezuela 1061
 Telephone: 58 212 985 3092
 Telefax: 58 212 985 1007

Asia Pacific

Flowserve Pte. Ltd.
 10 Tuas Loop
 Singapore 637345
 Telephone: 65 6771 0600
 Telefax: 65 6779 4607